

SIEMENS

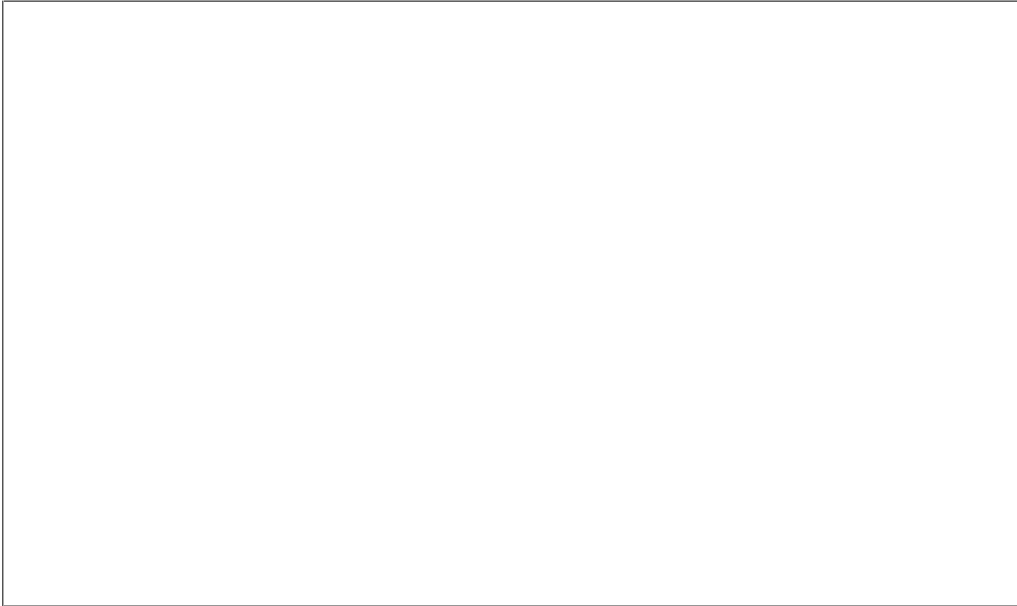

Microcomputer Components

C501

8-Bit CMOS Single-Chip Microcontroller

User's Manual 02.96

C501	
Revision History:	Current Version: 02.96
Previous Version:	08.93, 08.94
Page	Subjects (major changes since last revision)
1-8	P2 pin numbers corrected
1-9	N.C. pin numbers corrected
3-1	Figure 3-1 corrected
5-2	Figure 5-1: RESET signal corrected
6-5	Additional text about port structures added
6-7	Text modified (6.1.2)
6-36, 6-39	Text 3rd paragraph modified ('Transmission starts...')
8-2	Table 8-1: 3rd row modified
9-3	Note 4: measure condition modified Note 7: formula for $I_{CC\ max}$ added
9-4	t_{LLAX} corrected
9-5, 9-8	t_{LLAX2} corrected
9-9	20 MHz clock low/high/rise/fall times changed
9-10	Note*) supplemented
9-10 to 9-12	TBD values for 40 MHz specification added

Edition 02.96

This edition was realized using the software system FrameMaker®.

**Published by Siemens AG,
Bereich Halbleiter, Marketing-
Kommunikation, Balanstraße 73,
81541 München**

© Siemens AG 1996.
All Rights Reserved.

Attention please!

As far as patents or other rights of third parties are concerned, liability is only assumed for components, not for applications, processes and circuits implemented within components or assemblies.

The information describes the type of component and shall not be considered as assured characteristics.

Terms of delivery and rights to change design reserved.

For questions on technology, delivery and prices please contact the Semiconductor Group Offices in Germany or the Siemens Companies and Representatives worldwide (see address list).

Due to technical requirements components may contain dangerous substances. For information on the types in question please contact your nearest Siemens Office, Semiconductor Group.

Siemens AG is an approved CECC manufacturer.

Packing

Please use the recycling operators known to you. We can also help you – get in touch with your nearest sales office. By agreement we will take packing material back, if it is sorted. You must bear the costs of transport.

For packing material that is returned to us unsorted or which we are not obliged to accept, we shall have to invoice you for any costs incurred.

Components used in life-support devices or systems must be expressly authorized for such purpose!

Critical components¹ of the Semiconductor Group of Siemens AG, may only be used in life-support devices or systems² with the express written approval of the Semiconductor Group of Siemens AG.

- 1 A critical component is a component used in a life-support device or system whose failure can reasonably be expected to cause the failure of that life-support device or system, or to affect its safety or effectiveness of that device or system.
- 2 Life support devices or systems are intended (a) to be implanted in the human body, or (b) to support and/or maintain and sustain human life. If they fail, it is reasonable to assume that the health of the user may be endangered.

Table of Contents		Page
1	Introduction	1-1
2	Fundamental Structure	2-1
2.1	CPU	2-2
2.2	CPU Timing	2-4
3	Memory Organization	3-1
3.1	Program Memory, "Code Space"	3-2
3.2	Data Memory, "Data Space"	3-2
3.3	General Purpose Registers	3-2
3.4	Special Function Registers	3-3
4	External Bus Interface	4-1
4.1	Accessing External Memory	4-1
4.2	PSEN, Program Store Enable	4-3
4.3	ALE, Address Latch Enable	4-3
4.4	Overlapping External Data and Program Memory Spaces	4-3
5	System Reset	5-1
5.1	Hardware Reset	5-1
5.2	Hardware Reset Timing	5-2
6	On-Chip Peripheral Components	6-1
6.1	Parallel I/O	6-1
6.1.1	Port Structures	6-1
6.1.2	Port 0 and Port 2 used as Address/Data Bus	6-7
6.1.3	Alternate Functions	6-8
6.1.4	Port Handling	6-10
6.1.4.1	Port Timing	6-10
6.1.4.2	Port Loading and Interfacing	6-11
6.1.4.3	Read-Modify-Write Feature of Ports 1, 2 and 3	6-11
6.2	Timers/Counters	6-13
6.2.1	Timer/Counter 0 and 1	6-14
6.2.1.1	Mode 0	6-17
6.2.1.2	Mode 1	6-18
6.2.1.3	Mode 2	6-19
6.2.1.4	Mode 3	6-20
6.2.2	Timer/Counter 2	6-21
6.2.2.1	Auto/Reload (Up or Down Counter)	6-23
6.2.2.2	Capture	6-26
6.3	Serial Interface (USART)	6-27
6.3.1	Multiprocessor Communications	6-28
6.3.2	Baud Rates	6-30
6.3.2.1	Using Timer 1 to Generate Baud Rates	6-31

Table of Contents		Page
6.3.2.2	Using Timer 2 to Generate Baud Rates	6-32
6.3.3	Details about Mode 0	6-34
6.3.4	Details about Mode 1	6-37
6.3.5	Details about Modes 2 and 3	6-40
7	Interrupt System	7-1
7.1	Interrupt Structure	7-3
7.2	Interrupt Sources and Vectors	7-3
7.3	Interrupt Control Bits	7-4
7.3.1	Interrupt Enables	7-4
7.3.2	Interrupt Priorities	7-5
7.4	How Interrupts are Handled	7-7
7.5	External Interrupts	7-8
7.6	Response Time	7-9
8	Power Saving Modes	8-1
8.1	Idle Mode	8-2
8.2	Power-Down Mode	8-4
9	Device Specifications	9-1

1 Introduction

The SAB-C501-L/C501-1R described in this document is compatible (also pin-compatible) with the SAB 80C52 and can be used for all present SAB 80C52 applications.

The SAB-C501-1R contains a non-volatile 8K×8 read-only program memory, a volatile 256×8 read/write data memory, four ports, three 16-bit timers/counters, a seven source, two priority level interrupt structure and a serial port. The SAB-C501-L is identical, except that it lacks the program memory on chip. Therefore the term SAB-C501 refers to all versions within this specification unless otherwise noted.

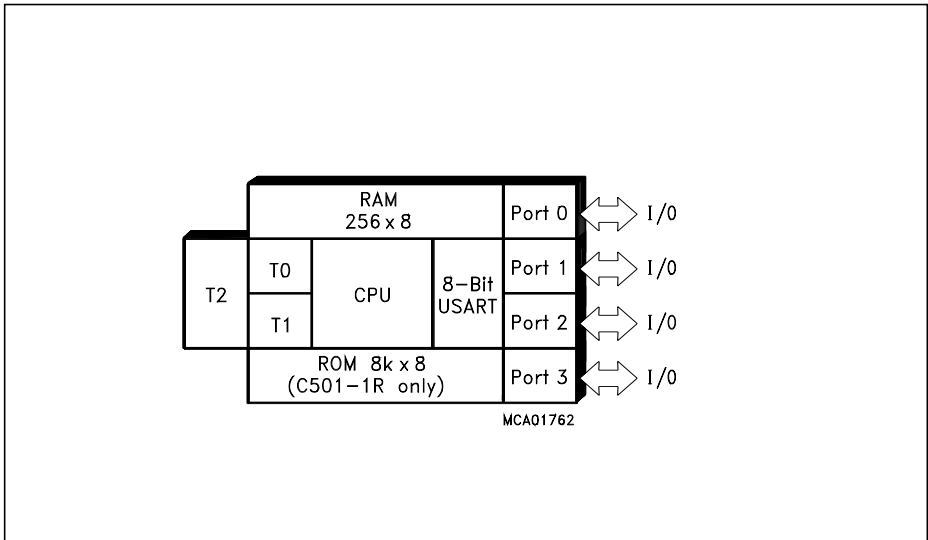

SAB-C501

Listed below is a summary of the main features of the SAB-C501:

- Fully compatible to standard 8051 microcontroller
- Versions for 12/20/40 MHz operating frequency
- 8 K×8 ROM (SAB-C501-1R only)
- 256×8 RAM
- Four 8-bit ports
- Three 16-bit Timers / Counters (Timer 2 with Up/Down Counter feature)
- USART
- Six interrupt sources, two priority levels
- Power Saving Modes
- P-DIP-40 and P-LCC-44 package
- Temperature ranges: SAB-C501 T_A : 0 to 70°C
 SAF-C501 T_A : - 40 to 85°C

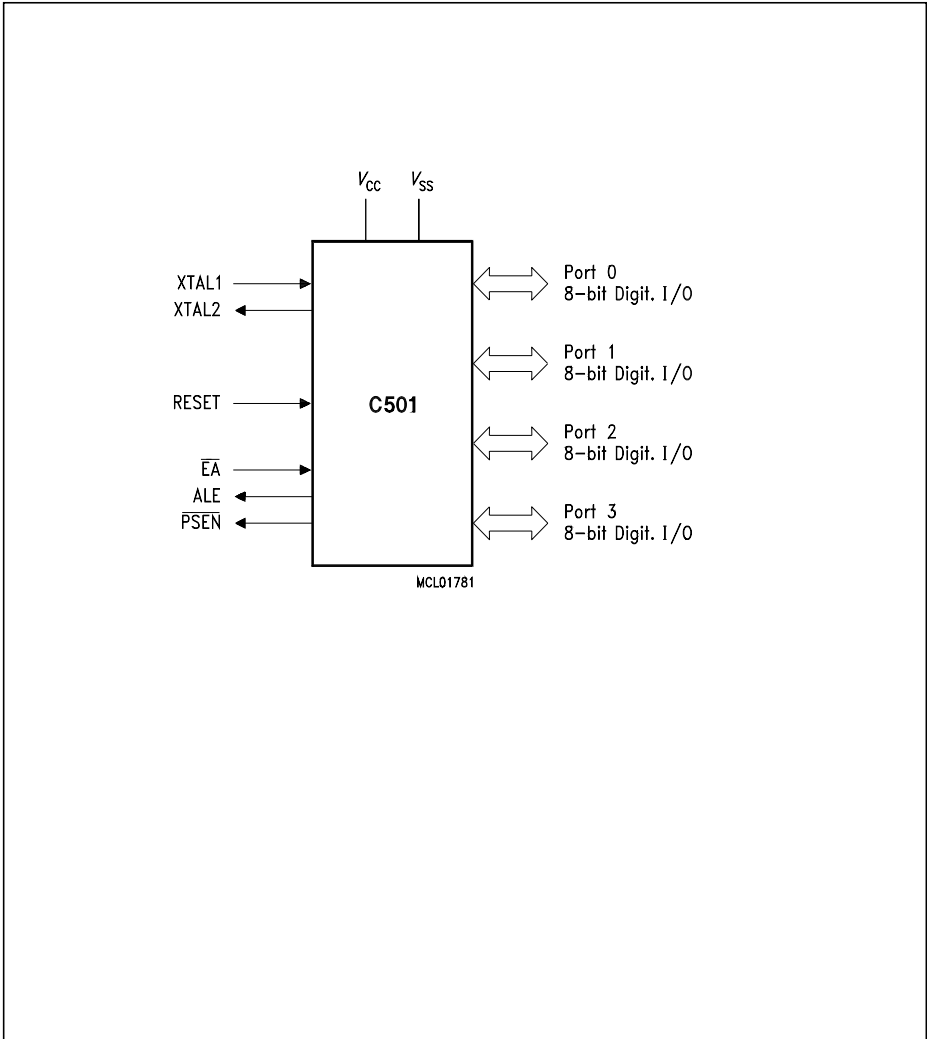

Logic Symbol

Pin Configuration (top view)

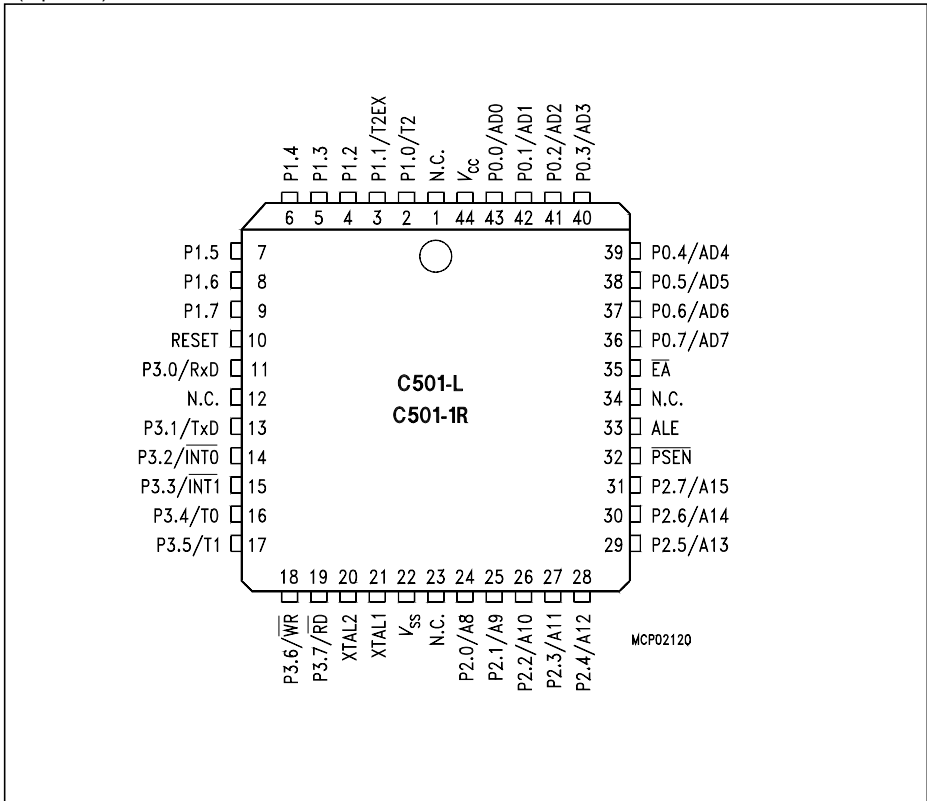

Pin Configuration
(top view)

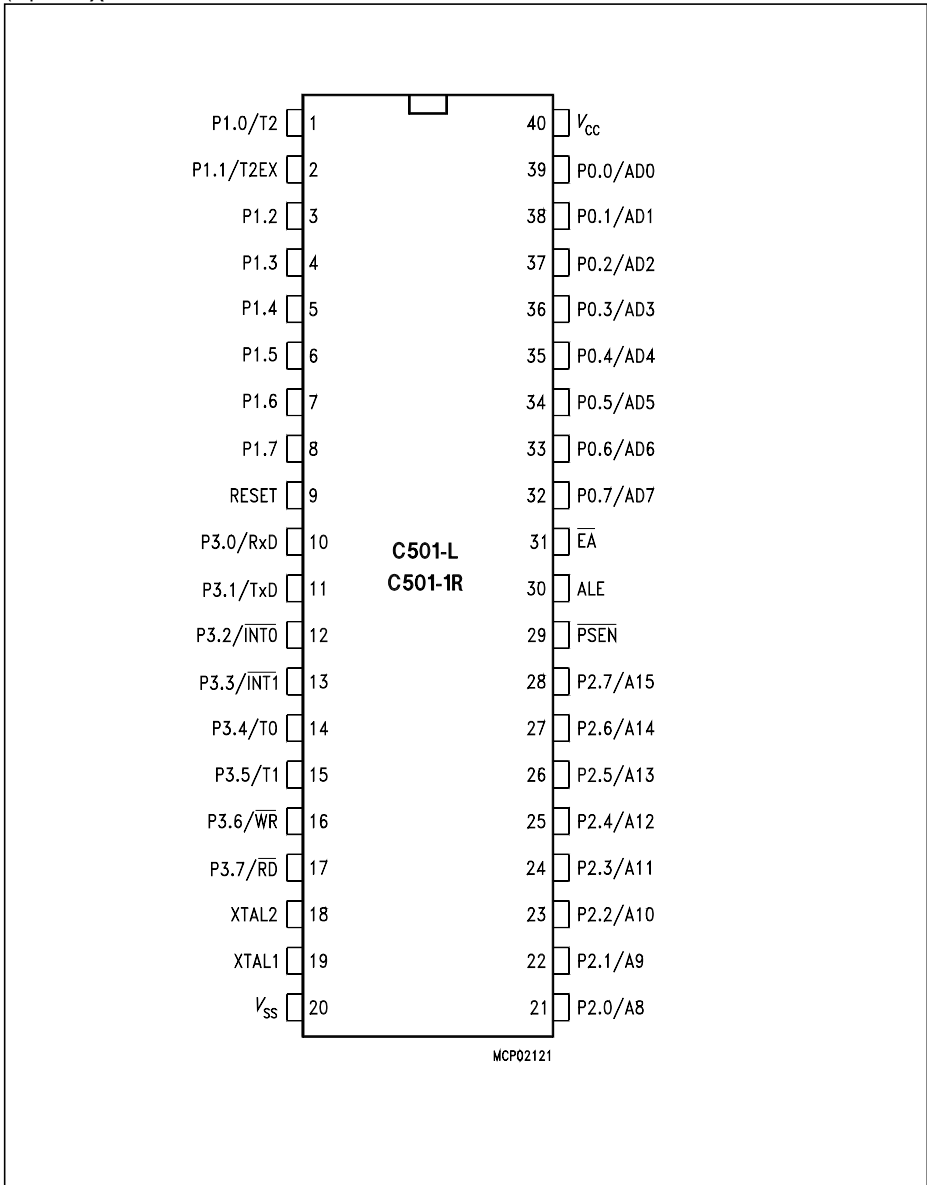

Pin Definitions and Functions

Symbol	Pin Number		I/O)	Function						
	P-LCC-44	P-DIP-40								
P1.7-P1.0	9-2	8-1	I	<p>Port 1 is a bidirectional I/O port with internal pull-up resistors. Port 1 pins that have 1s written to them are pulled high by the internal pullup resistors, and in that state can be used as inputs. As inputs, port 1 pins being externally pulled low will source current (IIL, in the DC characteristics) because of the internal pullup resistors. Port 1 also contains the timer 2 pins as secondary function. The output latch corresponding to a secondary function must be programmed to a one (1) for that function to operate.</p> <p>The secondary functions are assigned to the pins of port 1, as follows:</p> <table border="0"> <tr> <td>P1.0</td> <td>T2</td> <td>Input to counter 2</td> </tr> <tr> <td>P1.1</td> <td>T2EX</td> <td>Capture -Reload trigger of timer 2 Up-Down count</td> </tr> </table>	P1.0	T2	Input to counter 2	P1.1	T2EX	Capture -Reload trigger of timer 2 Up-Down count
	P1.0	T2			Input to counter 2					
P1.1	T2EX	Capture -Reload trigger of timer 2 Up-Down count								
	2 3	1 2								

*) I = Input
O = Output

Pin Definitions and Functions (cont'd)

Symbol	Pin Number		I/O (*)	Function
	P-LCC-44	P-DIP-40		
P3.0-P3.7	11, 13-19	10-17	I/O	<p>Port 3 is a bidirectional I/O port with internal pull-up resistors. Port 3 pins that have 1s written to them are pulled high by the internal pullup resistors, and in that state can be used as inputs. As inputs, port 3 pins being externally pulled low will source current (I_{IL}, in the DC characteristics) because of the internal pullup resistors. Port 3 also contains the interrupt, timer, serial port 0 and external memory strobe pins that are used by various options. The output latch corresponding to a secondary function must be programmed to a one (1) for that function to operate.</p> <p>The secondary functions are assigned to the pins of port 3, as follows</p>
	11	10	P3.0	R×D receiver data input (asynchronous) or data input/output (synchronous) of serial interface 0
	13	11	P3.1	T×D: transmitter data output (asynchronous) or clock output (synchronous) of serial interface 0
	14	12	P3.2	$\overline{INT0}$ interrupt 0 \overline{input} /timer 0 gate control
	15	13	P3.3	$\overline{INT1}$ interrupt 1 \overline{input} /timer 1 gate control
	16	14	P3.4	T0 counter 0 input
	17	15	P3.5	T1 counter 1 input
	18	16	P3.6	\overline{WR} write control signal latches the data byte from port 0 into the external data memory
	19	17	P3.7	\overline{RD} the read control signal enables the external data memory to port 0
	XTAL2	20	18	–

*) 1 = Input
O = Output

Pin Definitions and Functions (cont'd)

Symbol	Pin Number		I/O (*)	Function
	P-LCC-44	P-DIP-40		
XTAL1	21	19	–	<p>XTAL1 Input to the inverting oscillator amplifier and input to the internal clock generator circuits. To drive the device from an external clock source, XTAL1 should be driven, while XTAL2 is left unconnected. There are no requirements on the duty cycle of the external clock signal, since the input to the internal clocking circuitry is divided down by a divide-by-two flip-flop. Minimum and maximum high and low times as well as rise/fall times specified in the AC characteristics must be observed.</p>
P2.0-P2.7	24-31	21-28	I/O	<p>Port 2 is a bidirectional I/O port with internal pullup resistors. Port 2 pins that have 1s written to them are pulled high by the internal pullup resistors, and in that state can be used as inputs. As inputs, port 2 pins being externally pulled low will source current (I_{IL}, in the DC characteristics) because of the internal pullup resistors. Port 2 emits the high-order address byte during fetches from external program memory and during accesses to external data memory that use 16-bit addresses (MOVX @DPTR). In this application it uses strong internal pullup resistors when issuing 1s. During accesses to external data memory that use 8-bit addresses (MOVX @Ri), port 2 issues the contents of the P2 special function register.</p>
PSEN	32	29	O	<p>The Program Store Enable output is a control signal that enables the external program memory to the bus during external fetch operations. It is activated every six oscillator periods except during external data memory accesses. Remains high during internal program execution.</p>
RESET	10	9	I	<p>RESET A high level on this pin for two machine cycles while the oscillator is running resets the device. An internal diffused resistor to V_{SS} permits power-on reset using only an external capacitor to V_{CC}.</p>

*) I = Input
O = Output

Pin Definitions and Functions (cont'd)

Symbol	Pin Number		I/O))	Function
	P-LCC-44	P-DIP-40		
ALE	33	30	O	The Address Latch Enable output is used for latching the low-byte of the address into external memory during normal operation. It is activated every six oscillator periodes except during an external data memory access.
\overline{EA}	35	31	I	External Access Enable When held at high level, instructions are fetched from the internal ROM (SAB-C501-1R only) when the PC is less than 2000 _H . When held at low level, the SAB-C501 fetches all instructions from external program memory. For the SAB-C501-L this pin must be tied low.
P0.0-P0.7	43-36	39-32	I/O	Port 0 is an 8-bit open-drain bidirectional I/O port. Port 0 pins that have 1s written to them float, and in that state can be used as high-impedance inputs. Port 0 is also the multiplexed low-order address and data bus during accesses to external program or data memory. In this application it uses strong internal pullup resistors when issuing 1s. Port 0 also outputs the code bytes during program verification in the SAB-C501-1R if ROM-protection was not enabled. External pullup resistors are required during program verification.
V_{ss}	22	20	–	Circuit ground potential
V_{cc}	44	40	–	Supply terminal for all operating modes
N.C.	1, 12, 23, 34	–	–	No connection

*)=Input
O=Output

2 Fundamental Structure

The SAB-C501 is fully compatible to the standard 8051 microcontroller family

It is compatible with the SAB 80C52. While maintaining all architectural and operational characteristics of the SAB 80C52 the SAB-C501 incorporates some enhancements in the Timer 2 and Fail Save Mechanism Unit.

Figure 2-1 shows a block diagram of the SAB-C501.

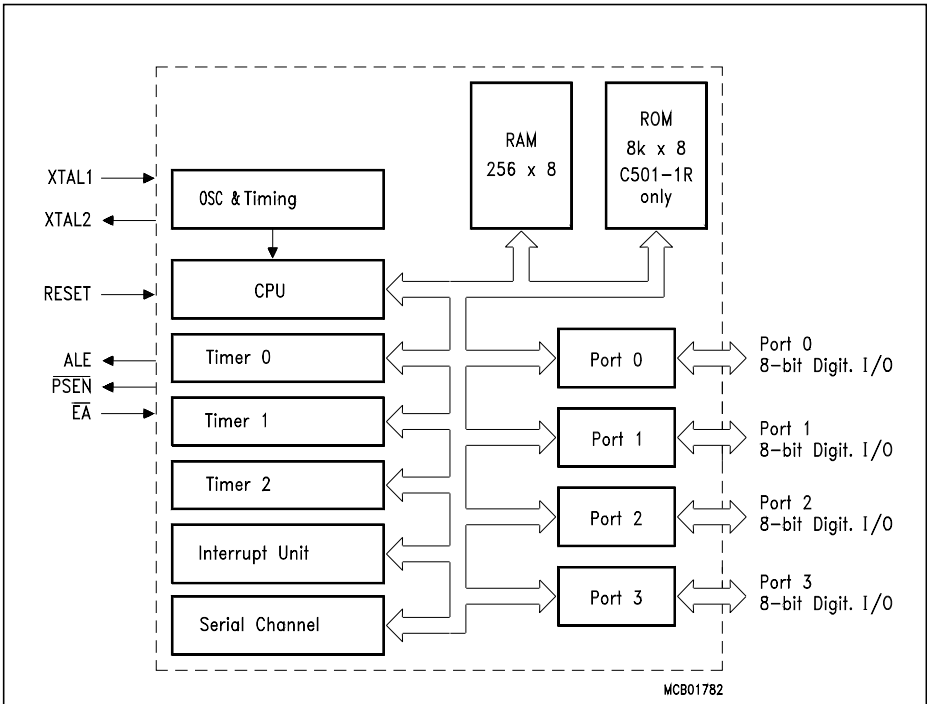

Figure 2-1
Block Diagram of the SAB-C501

2.1 CPU

The SAB-C501 is efficient both as a controller and as an arithmetic processor. It has extensive facilities for binary and BCD arithmetic and excels in its bit-handling capabilities. Efficient use of program memory results from an instruction set consisting of 44% one-byte, 41% two-byte, and 15% three-byte instructions. With a 12 MHz crystal, 58% of the instructions execute in 1.0 μ s (20 MHz : 600 ns, 40 MHz : 300 ns).

The CPU (Central Processing Unit) of the SAB-C501 consists of the instruction decoder, the arithmetic section and the program control section. Each program instruction is decoded by the instruction decoder. This unit generates the internal signals controlling the functions of the individual units within the CPU. They have an effect on the source and destination of data transfers, and control the ALU processing.

The arithmetic section of the processor performs extensive data manipulation and is comprised of the arithmetic/logic unit (ALU), an A register, B register and PSW register.

The ALU accepts 8-bit data words from one or two sources and generates an 8-bit result under the control of the instruction decoder. The ALU performs the arithmetic operations add, subtract, multiply, divide, increment, decrement, BDC-decimal-add-adjust and compare, and the logic operations AND, OR, Exclusive OR, complement and rotate (right, left or swap nibble (left four)). Also included is a Boolean processor performing the bit operations as set, clear, complement, jump-if-not-set, jump-if-set-and-clear and move to/from carry. Between any addressable bit (or its complement) and the carry flag, it can perform the bit operations of logical AND or logical OR with the result returned to the carry flag.

The program control section controls the sequence in which the instructions stored in program memory are executed. The 16-bit program counter (PC) holds the address of the next instruction to be executed. The conditional branch logic enables internal and external events to the processor to cause a change in the program execution sequence.

Accumulator

ACC is the symbol for the accumulator register. The mnemonics for accumulator-specific instructions, however, refer to the accumulator simply as A.

Program Status Word

The Program Status Word (PSW) contains several status bits that reflect the current state of the CPU.

Special Function Register PSW (Address D0_H)

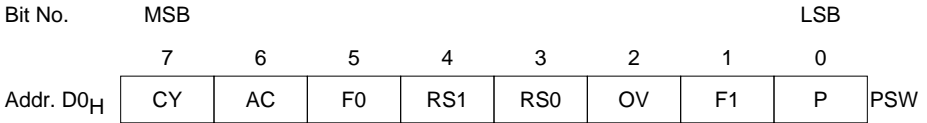

Bit	Function
CY	Carry Flag
AC	Auxiliary Carry Flag (for BCD operations)
F0	General Purpose Flag
RS1	Register Bank select control bits
0	0 Bank 0 selected, data address 00 _H -07 _H
0	1 Bank 1 selected, data address 08 _H -0F _H
1	0 Bank 2 selected, data address 10 _H -17 _H
1	1 Bank 3 selected, data address 18 _H -1F _H
OV	Overflow Flag
F1	General Purpose Flag
P	Parity Flag Set/cleared by hardware each instruction cycle to indicate an odd/ even number of "one" bits in the accumulator, i.e. even parity.

Reset value of PSW is 00_H

B Register

The B register is used during multiply and divide and serves as both source and destination. For other instructions it can be treated as another scratch pad register.

Stack Pointer

The stack pointer (SP) register is 8 bits wide. It is incremented before data is stored during PUSH and CALL executions and decremented after data is popped during a POP and RET (RETI) execution, i.e. it always points to the last valid stack byte. While the stack may reside anywhere in the on-chip RAM, the stack pointer is initialized to 07_H after a reset. This causes the stack to begin a location = 8_H above register bank zero. The SP can be read or written under software control.

2.2 CPU Timing

A machine cycle consists of 6 states (12 oscillator periods). Each state is divided into a phase 1 half, during which the phase 1 clock is active, and a phase 2 half, during which the phase 2 clock is active. Thus, a machine cycle consists of 12 oscillator periods, numbered S1P1 (state 1, phase 1) through S6P2 (state 6, phase 2). Each state lasts for two oscillator periods. Typically, arithmetic and logically operations take place during phase 1 and internal register-to-register transfers take place during phase 2.

The diagrams in **figure 2-2** show the fetch/execute timing related to the internal states and phases. Since these internal clock signals are not user-accessible, the XTAL2 oscillator signals and the ALE (address latch enable) signal are shown for external reference. ALE is normally activated twice during each machine cycle: once during S1P2 and S2P1, and again during S4P2 and S5P1.

Executing of a one-cycle instruction begins at S1P2, when the op-code is latched into the instruction register. If it is a two-byte instruction, the second reading takes place during S4 of the same machine cycle. If it is a one-byte instruction, there is still a fetch at S4, but the byte read (which would be the next op-code) is ignored (discarded fetch), and the program counter is not incremented. In any case, execution is completed at the end of S6P2.

Figures 2-2 a) and b) show the timing of a 1-byte, 1-cycle instruction and for a 2-byte, 1-cycle instruction.

Most SAB-C501 instructions are executed in one cycle. MUL (multiply) and DIV (divide) are the only instructions that take more than two cycles to complete; they take four cycles. Normally two code bytes are fetched from the program memory during every machine cycle. The only exception to this is when a MOVX instruction is executed. MOVX is a one-byte, 2-cycle instruction that accesses external data memory. During a MOVX, the two fetches in the second cycle are skipped while the external data memory is being addressed and strobed. **Figure 2-2 c) and d)** show the timing for a normal 1-byte, 2-cycle instruction and for a MOVX instruction.

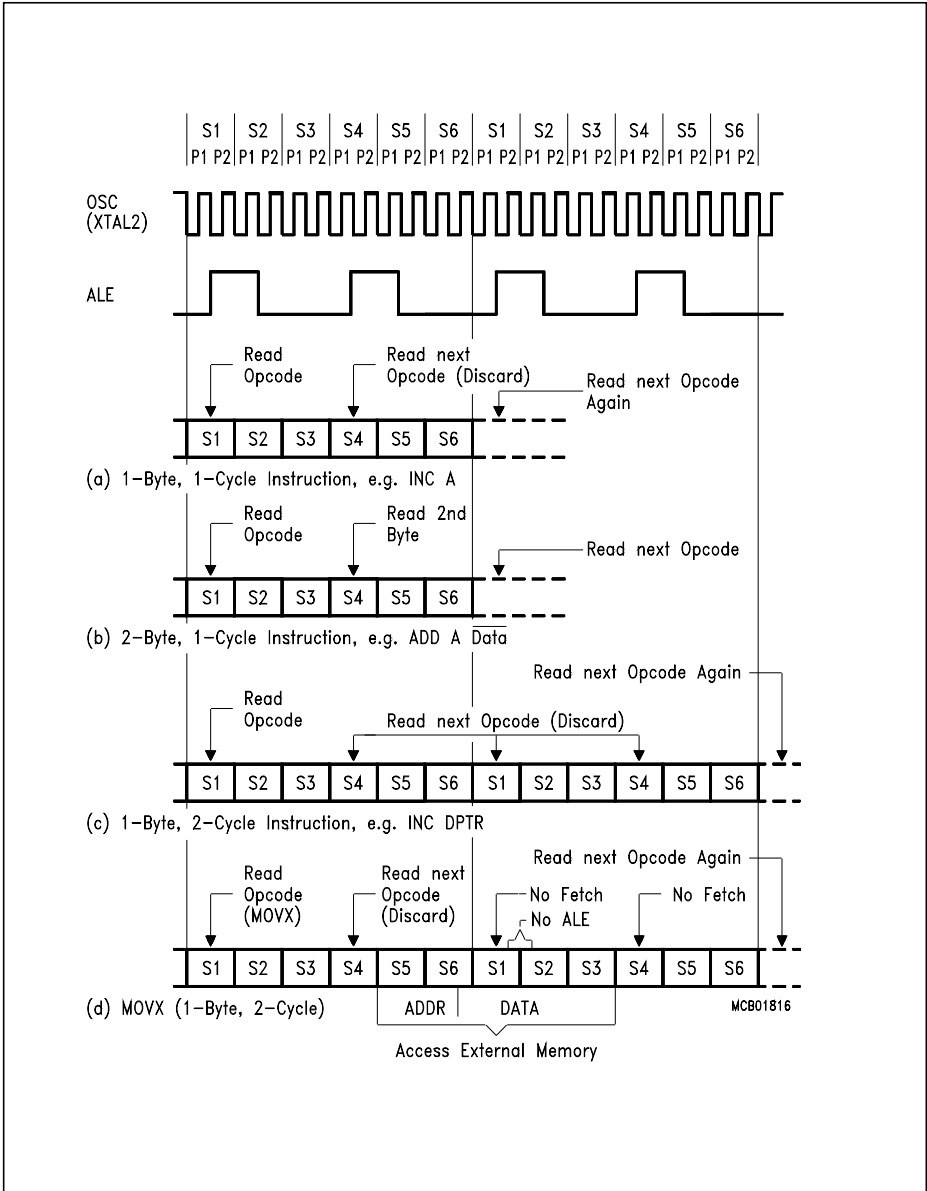

Figure 2-2
 Fetch Execute Sequence

3 Memory Organization

The SAB-C501 CPU manipulates operands in the following four address spaces:

- up to 64 Kbyte of external program memory
- up to 64 Kbyte of external data memory
- 256 bytes of internal data memory
- a 128 byte special function register area

Figure 3-1 illustrates the memory address spaces of the SAB-C501.

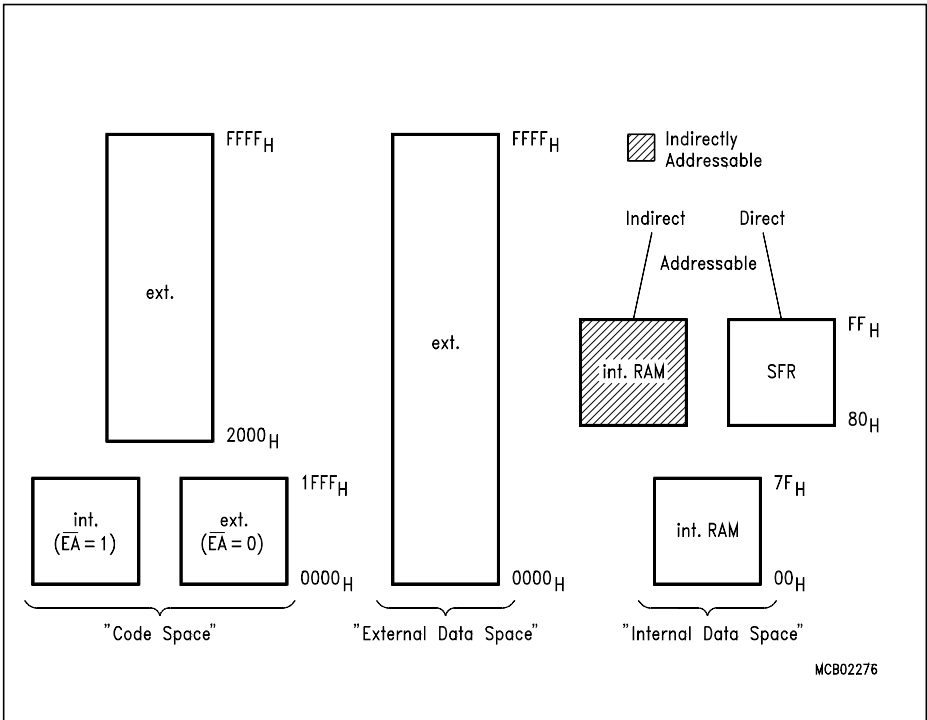

Figure 3-1
Memory Map

3.1 Program Memory, "Code Space"

The SAB-C501-1R has 8 Kbytes of read-only program memory, while the SAB-C501-L has no internal program memory. The program memory can be externally expanded up to 64 Kbytes. If the \overline{EA} pin is held high, the SAB-C501 executes out of internal ROM unless the address exceeds $1FFF_H$. Locations 2000_H through $FFFF_H$ are then fetched from the external program memory. If the \overline{EA} pin is held low, the SAB-C501 fetches all instructions from the external program memory.

3.2 Data Memory, "Data Space"

The data memory address space consists of an internal and an external memory space. The internal data memory is divided into three physically separate and distinct blocks:

The lower 128 bytes of RAM, the upper 128 bytes of RAM, and the 128 byte special function register (SFR) area. While the upper 128 bytes of data memory and the SFR area share the same address locations, they are accessed through different addressing modes. The lower 128 bytes of data memory can be accessed through direct or register indirect addressing; the upper 128 bytes of RAM can be accessed through register indirect addressing; the special function registers are accessible through direct addressing. Four 8-register banks, each bank consisting of eight 8-bit multi-purpose registers, occupy locations 0 through $1F_H$ in the lower RAM area. The next 16 bytes, locations 20_H through $2F_H$, contain 128 directly addressable bit locations. The stack can be located anywhere in the internal data memory address space, and the stack depth can be expanded up to 256 bytes.

The external data memory can be expanded up to 64 Kbytes and can be accessed by instructions that use a 16-bit or an 8-bit address.

3.3 General Purpose Registers

The lower 32 locations of the internal RAM are assigned to four banks with eight general purpose registers (GPRs) each. Only one of these banks may be enabled at a time. Two bits in the program status word, PSW.3 and PSW.4, select the active register bank (see description of the PSW). This allows fast context switching, which is useful when entering subroutines or interrupt service routines. ASM51 and the device SAB C501 default to register bank 0.

The 8 general purpose registers of the selected register bank may be accessed by register addressing. With register addressing the instruction op code indicates which register is to be used. For indirect addressing R0 and R1 are used as pointer or index register to address internal or external memory (e.g. MOV @R0).

Reset initializes the stack pointer to location 07_H and increments it once to start from location 08_H which is also the first register (R0) of register bank 1. Thus, if one is going to use more than one register bank, the SP should be initialized to a different location of the RAM which is not used for data storage.

3.4 Special Function Registers

All registers, except the program counter and the four general purpose register banks, reside in the special function register area.

The 27 special function register (SFR) include pointers and registers that provide an interface between the CPU and the other on-chip peripherals. There are also 128 directly addressable bits within the SFR area.

All SFRs are listed in **table 3-1**, **table 3-2** and **table 3-2**.

In **table 3-1** they are organized in numeric order of their addresses. In **table 3-2** they are organized in groups which refer to the functional blocks of the SAB-C501. **Table 3-3** illustrates the contents of the SFRs.

Table 3-1
Special Function Registers in Numeric Order of their Addresses

Address	Register	Contents after Reset	Address	Register	Contents after Reset
80H	P0¹⁾	FFH	98H	SCON¹⁾	00H
81H	SP	07H	99H	SBUF	XXH ²⁾
82H	DPL	00H	9AH	reserved	XXH ²⁾
83H	DPH	00H	9BH	reserved	XXH ²⁾
84H	reserved	XXH	9CH	reserved	XXH ²⁾
85H	reserved	XXH	9DH	reserved	XXH ²⁾
86H	reserved	XXH	9EH	reserved	XXH ²⁾
87H	PCON	0XXX0000B ²⁾	9FH	reserved	XXH ²⁾
88H	TCON¹⁾	00H	A0H	P2¹⁾	FFH
89H	TMOD	00H	A1H	reserved	XXH ²⁾
8AH	TL0	00H	A2H	reserved	XXH ²⁾
8BH	TL1	00H	A3H	reserved	XXH ²⁾
8CH	TH0	00H	A4H	reserved	XXH ²⁾
8DH	TH1	00H	A5H	reserved	XXH ²⁾
8EH	reserved	XXH ²⁾	A6H	reserved	XXH ²⁾
8FH	reserved	XXH ²⁾	A7H	reserved	XXH ²⁾
90H	P1¹⁾	FFH	A8H	IE¹⁾	0X00000B²⁾
91H	reserved	00H	A9H	reserved	XXH ²⁾
92H	reserved	XXH ²⁾	AAH	reserved	XXH ²⁾
93H	reserved	XXH ²⁾	ABH	reserved	XXH ²⁾
94H	reserved	XXH ²⁾	ACH	reserved	XXH ²⁾
95H	reserved	XXH ²⁾	ADH	reserved	XXH ²⁾
96H	reserved	XXH ²⁾	AEH	reserved	XXH ²⁾
97H	reserved	XXH ²⁾	A FH	reserved	XXH ²⁾

1) : Bit-addressable Special Function Register
 2) : X means that the value is undefined and the location is reserved

Table 3-1, Special Function Registers in Numeric Order of their Addresses (cont'd)

Address	Register	Contents after Reset	Address	Register	Contents after Reset
B0_H	P3¹⁾	FF_H	D8_H	reserved	XX _H ²⁾
B1 _H	reserved	XX _H ²⁾	D9 _H	reserved	XX _H ²⁾
B2 _H	reserved	XX _H ²⁾	DA _H	reserved	XX _H ²⁾
B3 _H	reserved	XX _H ²⁾	DB _H	reserved	XX _H ²⁾
B4 _H	reserved	XX _H ²⁾	DC _H	reserved	XX _H ²⁾
B5 _H	reserved	XX _H ²⁾	DD _H	reserved	XX _H ²⁾
B6 _H	reserved	XX _H ²⁾	DE _H	reserved	XX _H ²⁾
B7 _H	reserved	XX _H ²⁾	DF _H	reserved	XX _H ²⁾
B8_H	IP¹⁾	XX000000_B²⁾	E0_H	ACC¹⁾	00_H
B9 _H	reserved	XX _H ²⁾	E1 _H	reserved	XX _H ²⁾
BA _H	reserved	XX _H ²⁾	E2 _H	reserved	XX _H ²⁾
BB _H	reserved	XX _H ²⁾	E3 _H	reserved	XX _H ²⁾
BC _H	reserved	XX _H ²⁾	E4 _H	reserved	XX _H ²⁾
BD _H	reserved	XX _H ²⁾	E5 _H	reserved	XX _H ²⁾
BE _H	reserved	XX _H ²⁾	E6 _H	reserved	XX _H ²⁾
BF _H	reserved	XX _H ²⁾	E7 _H	reserved	XX _H ²⁾
C0_H	reserved	XX _H ²⁾	E8_H	reserved	XX_H²⁾
C1 _H	reserved	XX _H ²⁾	E9 _H	reserved	XX _H ²⁾
C2 _H	reserved	XX _H ²⁾	EA _H	reserved	XX _H ²⁾
C3 _H	reserved	XX _H ²⁾	EB _H	reserved	XX _H ²⁾
C4 _H	reserved	XX _H ²⁾	EC _H	reserved	XX _H ²⁾
C4 _H	reserved	XX _H ²⁾	ED _H	reserved	XX _H ²⁾
C6 _H	reserved	XX _H ²⁾	EE _H	reserved	XX _H ²⁾
C7 _H	reserved	XX _H ²⁾	EF _H	reserved	XX _H ²⁾
C8_H	T2CON¹⁾	00_H	F0_H	B¹⁾	00_H
C9 _H	T2MOD	XXXXXXX0 _B ²⁾	F1 _H	reserved	XX _H ²⁾
CA _H	RC2L	00 _H	F2 _H	reserved	XX _H ²⁾
CB _H	RC2H	00 _H	F3 _H	reserved	XX _H ²⁾
CC _H	TL2	00 _H	F4 _H	reserved	XX _H ²⁾
CD _H	TH2	00 _H	F5 _H	reserved	XX _H ²⁾
CE _H	reserved	XX _H ²⁾	F6 _H	reserved	XX _H ²⁾
CF _H	reserved	XX _H ²⁾	F7 _H	reserved	XX _H ²⁾
D0_H	PSW¹⁾	00_H	F8_H	reserved	XX_H²⁾
D1 _H	reserved	XX _H ²⁾	F9 _H	reserved	XX _H ²⁾
D2 _H	reserved	XX _H ²⁾	FA _H	reserved	XX _H ²⁾
D3 _H	reserved	XX _H ²⁾	FB _H	reserved	XX _H ²⁾
D4 _H	reserved	XX _H ²⁾	FC _H	reserved	XX _H ²⁾
D5 _H	reserved	XX _H ²⁾	FD _H	reserved	XX _H ²⁾
D6 _H	reserved	XX _H ²⁾	FE _H	reserved	XX _H ²⁾
D7 _H	reserved	XX _H ²⁾	FF _H	reserved	XX _H ²⁾

1) : Bit-addressable Special Function Register

2) : X means that the value is undefined and the location is reserved

Table 3-2
Special Function Registers - Functional Blocks

Block	Symbol	Name	Address	Contents after Reset
CPU	ACC	Accumulator	E0H ¹⁾	00H
	B	B-Register	F0H ¹⁾	00H
	DPH	Data Pointer, High Byte	83H	00H
	DPL	Data Pointer, Low Byte	82H	00H
	PSW	Program Status Word Register	D0H ¹⁾	00H
	SP	Stack Pointer	81H	07H
Interrupt System	IE	Interrupt Enable Register	A8H ¹⁾	0X000000B ³⁾
	IP	Interrupt Priority Register	B8H ¹⁾	XX000000B ³⁾
Ports	P0	Port 0	80H ¹⁾	FFH
	P1	Port 1	90H ¹⁾	XXH ³⁾
	P2	Port 2	A0H ¹⁾	FFH
	P3	Port 3	B0H ¹⁾	FFH
Serial Channels	PCON ²⁾	Power Control Register	87H	0XXX0000B ³⁾
	SBUF	Serial Channel Buffer Register	99H	XXH ³⁾
	SCON	Serial Channel 0 Control Register	98H ¹⁾	00H
Timer 0/ Timer 1	TCON	Timer 0/1 Control Register	88H ¹⁾	00H
	TH0	Timer 0, High Byte	8CH	00H
	TH1	Timer 1, High Byte	8DH	00H
	TL0	Timer 0, Low Byte	8AH	00H
	TL1	Timer 1, Low Byte	8BH	00H
	TMOD	Timer Mode Register	89H	00H
Timer 2	T2CON	Timer 2 Control Register	C8H ¹⁾	00H
	T2MOD	Timer 2 Mode Register	C9H	00H
	RC2H	Timer 2 Reload Capture Register, High Byte	CBH	00H
	RC2L	Timer 2 Reload Capture Register, Low Byte	CAH	00H
	TH2	Timer 2 High Byte	CDH	00H
	TL2	Timer 2 Low Byte	CCH	00H
Pow. Save Mode	PCON	Power Control Register	87H	0XXX0000B ³⁾

1) Bit-addressable special function registers

2) This special function register is listed repeatedly since some bits of it also belong to other functional blocks.

3) X means that the value is undefined and the location is reserved

Table 3-3
Contents of SFRs, SFRs in Numeric Order

Address	Register	Bit 7	6	5	4	3	2	1	0
80 _H	P0								
81 _H	SP								
82 _H	DPL								
83 _H	DPH								
87 _H	PCON	SMOD	-	-	-	GF1	GF0	PDE	IDLE
88 _H	TCON	TF1	TR1	TF0	TR0	IE1	IT1	IE0	IT0
89 _H	TMOD	GATE	C/ \bar{T}	M1	M0	GATE	C/ \bar{T}	M1	M0
8A _H	TL0								
8B _H	TL1								
8C _H	TH0								
8D _H	TH1								
90 _H	P1								
98 _H	SCON	SM0	SM1	SM2	REN	TB8	RB8	TI	RI
99 _H	SBUF								
A0 _H	P2								
A8 _H	IE	EA	-	ET2	ES	ET1	EX1	ET0	EX0
B0 _H	P3								
B8 _H	IP	-	-	PT2	PS	PT1	PX1	PT0	PX0
C8 _H	T2CON	TF2	EXF2	RCLK	TCLK	EXEN2	TR2	C/ \bar{T} 2	CP/RL2
C9 _H	T2MOD	-	-	-	-	-	-	-	DCEN



SFR bit and byte addressable

SFR not bit addressable

- : = bit location is reserved

Table 3-3
Contents of SFRs, SFRs in Numeric Order (cont'd)

Address	Register	Bit 7	6	5	4	3	2	1	0
CA _H	RC2L								
CB _H	RC2H								
CC _H	TL2								
CD _H	TH2								
D0 _H	PSW	CY	AC	F0	RS1	RS0	OV	F1	P
E0 _H	ACC								
F0 _H	B								

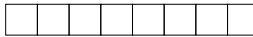

SFR bit and byte addressable

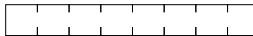

SFR not bit addressable

- : = bit location is reserved

4 External Bus Interface

The SAB-C501 allows for external memory expansion. To accomplish this, the external bus interface common to most 8051-based controllers is employed.

4.1 Accessing External Memory

It is possible to distinguish between accesses to external program memory and external data memory or other peripheral components respectively. This distinction is made by hardware: accesses to external program memory use the signal $\overline{\text{PSEN}}$ (program store enable) as a read strobe. Accesses to external data memory use $\overline{\text{RD}}$ and $\overline{\text{WR}}$ to strobe the memory (alternate functions of P3.7 and P3.6). Port 0 and port 2 (with exceptions) are used to provide data and address signals. In this section only the port 0 and port 2 functions relevant to external memory accesses are described.

Fetches from external program memory always use a 16-bit address. Accesses to external data memory can use either a 16-bit address (MOVX @DPTR) or an 8-bit address (MOVX @Ri).

Role of P0 and P2 as Data/Address Bus

When used for accessing external memory, port 0 provides the data byte time-multiplexed with the low byte of the address. In this state, port 0 is disconnected from its own port latch, and the address/data signal drives both FETs in the port 0 output buffers. Thus, in this application, the port 0 pins are not open-drain outputs and do not require external pullup resistors.

During any access to external memory, the CPU writes FF_{H} to the port 0 latch (the special function register), thus obliterating whatever information the port 0 SFR may have been holding.

Whenever a 16-bit address is used, the high byte of the address comes out on port 2, where it is held for the duration of the read or write cycle. During this time, the port 2 lines are disconnected from the port 2 latch (the special function register).

Thus the port 2 latch does not have to contain 1s, and the contents of the port 2 SFR are not modified.

If an 8-bit address is used (MOVX @Ri), the contents of the port 2 SFR remain at the port 2 pins throughout the external memory cycle. This will facilitate paging. It should be noted that, if a port 2 pin outputs an address bit that is a 1, strong pullups will be used for the entire read/write cycle and not only for two oscillator periods.

Timing

The timing of the external bus interface, in particular the relationship between the control signals ALE, PSEN, RD, WR and information on port 0 and port 2, is illustrated in **figure 4-1 a)** and **b)**.

Data memory: in a write cycle, the data byte to be written appears on port 0 just before WR is activated and remains there until after WR is deactivated. In a read cycle, the incoming byte is accepted at port 0 before the read strobe is deactivated.

Program memory: Signal PSEN functions as a read strobe.

External Program Memory Access

The external program memory is accessed under two conditions:

- whenever signal EA is active: or
- whenever the program counter (PC) contains a number that is larger than 1FFF_H.

This requires the ROM-less version SAB-C501-L to have EA wired low to allow the lower 8K program bytes to be fetched from external memory.

When the CPU is executing out of external program memory, all 8 bits of port 2 are dedicated to an output function and may not be used for general-purpose I/O. The contents of the port 2 SFR however is not affected. During external program memory fetches port 2 lines output the high byte of the PC, and during accesses to external data memory they output either DPH or the port 2 SFR (depending on whether the external data memory access is a MOVX @DPTR or a MOVX @Ri).

Since the SAB-C501-L has no internal program memory, accesses to program memory are always external, and port 2 is at all times dedicated to output the high-order address byte. This means that port 0 and port 2 of the SAB-C501-L can never be used as general-purpose I/O. This also applies to the SAB-C501-1R when it is operated with only an external program memory.

4.2 $\overline{\text{PSEN}}$, Program Store Enable

The read strobe for external fetches is $\overline{\text{PSEN}}$. $\overline{\text{PSEN}}$ is not activated for internal fetches. When the CPU is accessing external program memory, $\overline{\text{PSEN}}$ is activated twice every cycle (except during a MOVX instruction) no matter whether or not the byte fetched is actually needed for the current instruction. When $\overline{\text{PSEN}}$ is activated its timing is not the same as for $\overline{\text{RD}}$. A complete $\overline{\text{RD}}$ cycle, including activation and deactivation of ALE and $\overline{\text{RD}}$, takes 12 oscillator periods. A complete $\overline{\text{PSEN}}$ cycle, including activation and deactivation of ALE and $\overline{\text{PSEN}}$ takes 6 oscillator periods. The execution sequence for these two types of read cycles is shown in **figure 4-1 a)** and **b)**.

4.3 ALE, Address Latch Enable

The main function of ALE is to provide a properly timed signal to latch the low byte of an address from P0 into an external latch during fetches from external memory. The address byte is valid at the negative transition of ALE. For that purpose, ALE is activated twice every machine cycle. This activation takes place even if the cycle involves no external fetch. The only time no ALE pulse comes out is during an access to external data memory when $\overline{\text{RD}}/\overline{\text{WR}}$ signals are active. The first ALE of the second cycle of a MOVX instruction is missing (**see figure 4-1 b)**). Consequently, in any system that does not use data memory, ALE is activated at a constant rate of 1/6 of the oscillator frequency and can be used for external clocking or timing purposes.

4.4 Overlapping External Data and Program Memory Spaces

In some applications it is desirable to execute a program from the same physical memory that is used for storing data. In the SAB-C501 the external program and data memory spaces can be combined by AND-ing $\overline{\text{PSEN}}$ and $\overline{\text{RD}}$. A positive logic AND of these two signals produces an active low read strobe that can be used for the combined physical memory. Since the $\overline{\text{PSEN}}$ cycle is faster than the $\overline{\text{RD}}$ cycle, the external memory needs to be fast enough to adapt to the $\overline{\text{PSEN}}$ cycle.

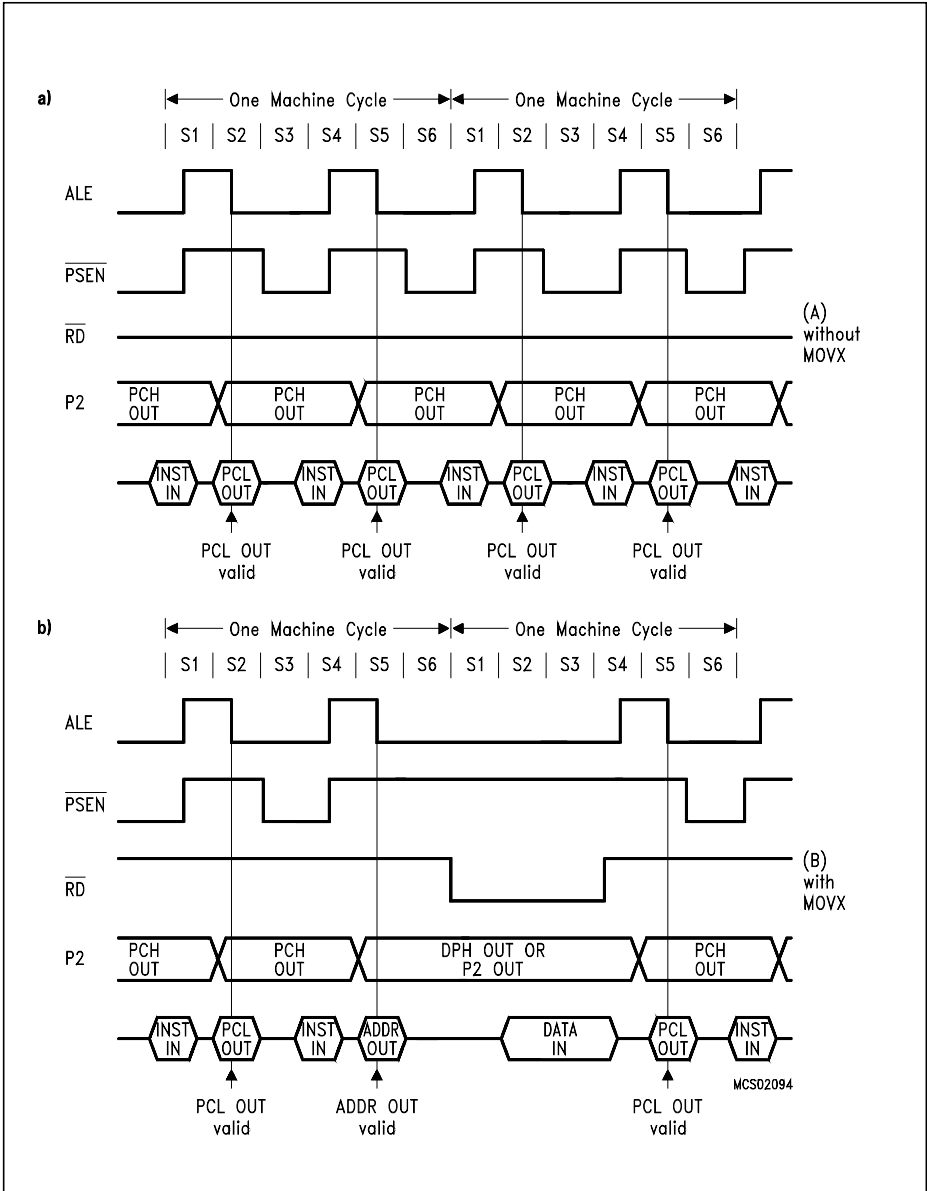

Figure 4-1 a) and b)
 External Program Memory Execution

5 System Reset

5.1 Hardware Reset

The hardware reset function incorporated in the SAB-C501 allows for an easy automatic start-up at a minimum of additional hardware and forces the controller to a predefined default state. The hardware reset function can also be used during normal operation in order to restart the device. This is particularly done when the power-down mode is to be terminated.

The reset input is an active high input. An internal Schmitt trigger is used at the input for noise rejection. Since the reset is synchronized internally, the RESET pin must be held high for at least one machine cycle (12 oscillator periods) while the oscillator is running. With the oscillator running the internal reset is executed during the second machine cycle and is repeated every cycle until RESET goes low again.

During reset, pins ALE and $\overline{\text{PSEN}}$ are configured as inputs and should not be stimulated externally. (An external stimulation at these lines during reset activates several test modes which are reserved for test purposes. This in turn may cause unpredictable output operations at several port pins).

A pullup resistor is internally connected to V_{CC} to allow a power-up reset with an external capacitor only. An automatic reset can be obtained when V_{CC} is applied by connecting the reset pin to V_{SS} via a capacitor. After V_{CC} has been turned on, the capacitor must hold the voltage level at the reset pin for a specified time to effect a complete reset.

A correct reset leaves the processor in a defined state. The program execution starts at location 0000_H. After reset is internally accomplished the port latches of ports 0, 1, 2 and 3 default in FF_H. This leaves port 0 floating, since it is an open drain port when not used as data/address bus. All other I/O port lines (ports 1, 2 and 3) output at one (1).

The contents of the internal RAM of the SAB-C501 is not affected by a reset. After power-up the contents is undefined, while it remains unchanged during a reset if the power supply is not turned off.

5.2 Hardware Reset Timing

This section describes the timing of the hardware reset signal.

The input pin RESET is sampled once during each machine cycle. This happens in state 5 phase 2. Thus, the external reset signal is synchronized to the internal CPU timing. When the reset is found active (high level) the internal reset procedure is started. It needs two complete machine cycles to put the complete device to its correct reset state, i.e. all special function registers contain their default values, the port latches contain 1's etc. The RESET signal must be active for at least one machine cycle; after this time the SAB-C501 remains in its reset state as long as the signal is active. When the signal goes inactive this transition is recognized in the following state 5 phase 2 of the machine cycle. Then the processor starts its address output (when configured for external ROM) in the following state 5 phase 1. One phase later (state 5 phase 2) the first falling edge at pin ALE occurs.

Figure 5-1 shows this timing for a configuration with $\overline{EA} = 0$ (external program memory). Thus, between the release of the RESET signal and the first falling edge at ALE there is a time period of at least one machine cycle but less than two machine cycles.

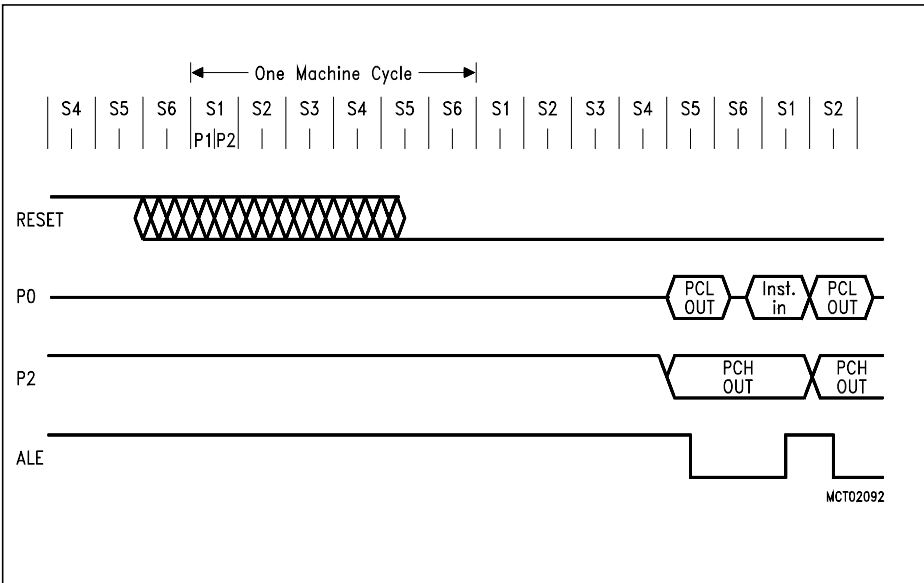

Figure 5-1 CPU Timing after Reset

6 On-Chip Peripheral Components

I/O Ports

The SAB-C501 has three 8-bit I/O ports and one 8-bit input port. Port 0 is an open-drain bidirectional I/O port, while ports 1 to 3 are quasi-bidirectional I/O ports with internal pullup resistors. That means, when configured as inputs, ports 1 to 3 will be pulled high and will source current when externally pulled low. Port 0 will float when configured as input.

The output drivers of port 0 and 2 and the input buffers of port 0 are also used for accessing external memory. In this application, port 0 outputs the low byte of the external memory address, time multiplexed with the byte being written or read. Port 2 outputs the high byte of the external memory address when the address is 16 bits wide. Otherwise, the port 2 pins continue emitting the P2 SFR contents. In this function, port 0 is not an open-drain port, but uses a strong internal pullup FET.

6.1 Parallel I/O

6.1.1 Port Structures

Digital I/O

The SAB-C501 allows for digital I/O on 32 lines grouped into 4 bidirectional 8-bit ports. Each port bit consists of a latch, an output driver and an input buffer. Read and write accesses to the I/O ports P0, P1, P2 and P3 are performed via their corresponding special function registers.

Digital I/O Port Circuitry

Figure 6-1 shows a functional diagram of a typical bit latch and I/O buffer, which is the core of each of the 4 I/O-ports. The bit latch (one bit in the port's SFR) is represented as a type-D flip-flop, which will clock in a value from the internal bus in response to a "write-to-latch" signal from the CPU. The Q output of the flip-flop is placed on the internal bus in response to a "read-latch" signal from the CPU. The level of the port pin itself is placed on the internal bus in response to a "read-pin" signal from the CPU. Some instructions that read from a port (i.e. from the corresponding port SFR P0 to P3) activate the "read-latch" signal, while others activate the "read-pin" signal.

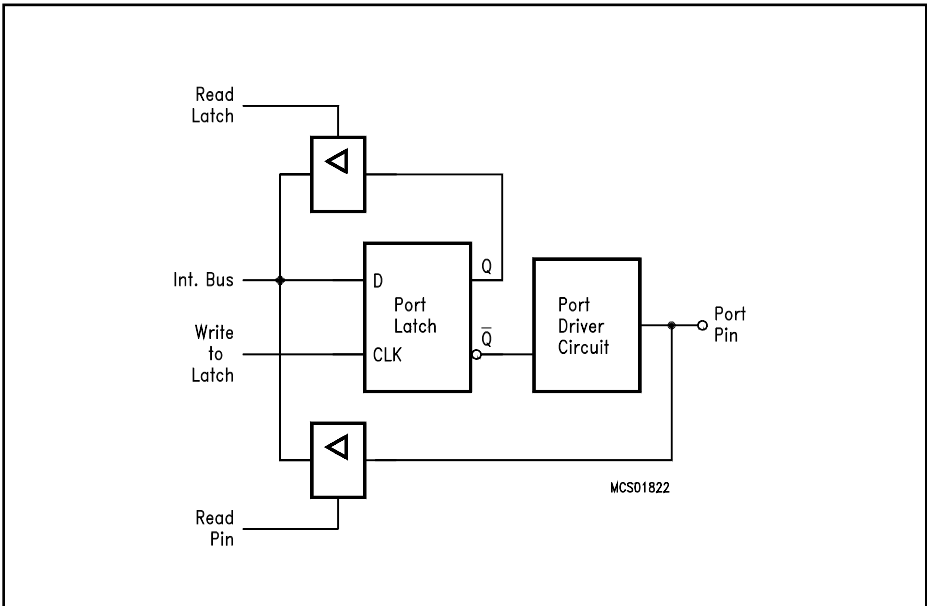

Figure 6-1
Basic Structure of a Port Circuitry

Port 1, 2 and 3 output drivers have internal pullup FET's (see figure 6-2). Each I/O line can be used independently as an input or output. To be used as an input, the port bit must contain a one (1) (that means for figure 6-2: $\bar{Q}=0$), which turns off the output driver FET n1. Then, for ports 1, 2 and 3, the pin is pulled high by the internal pullups, but can be pulled low by an external source. When externally pulled low the port pins source current (I_{IL} or I_{TL}). For this reason these ports are sometimes called "quasi-bidirectional".

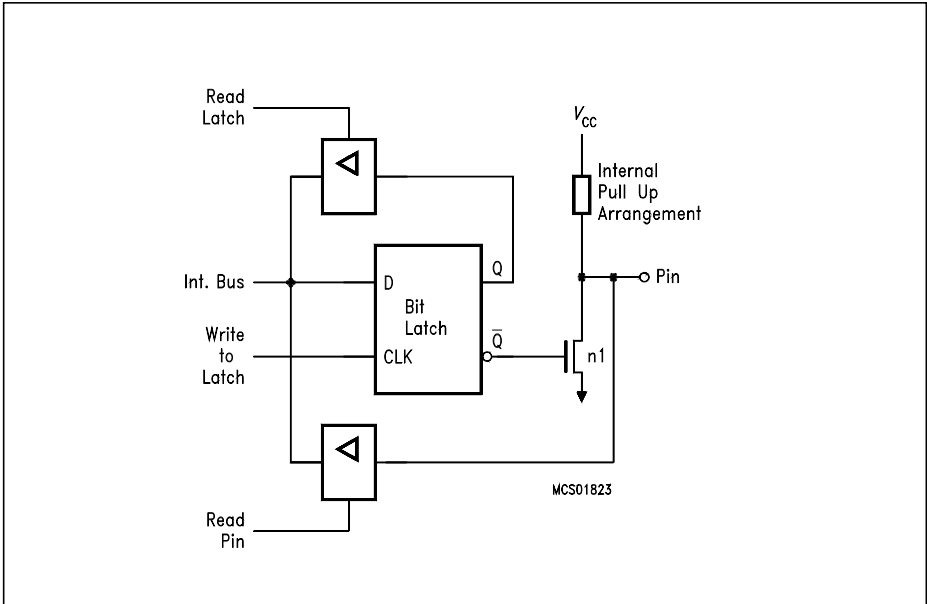

Figure 6-2
Basic Output Driver Circuit of Ports 1, 2 and 3

In fact, the pullups mentioned before and included in **figure 6-2** are pullup arrangements shown in **figure 6-3**. One n-channel pulldown FET and three pullup FETs are used:

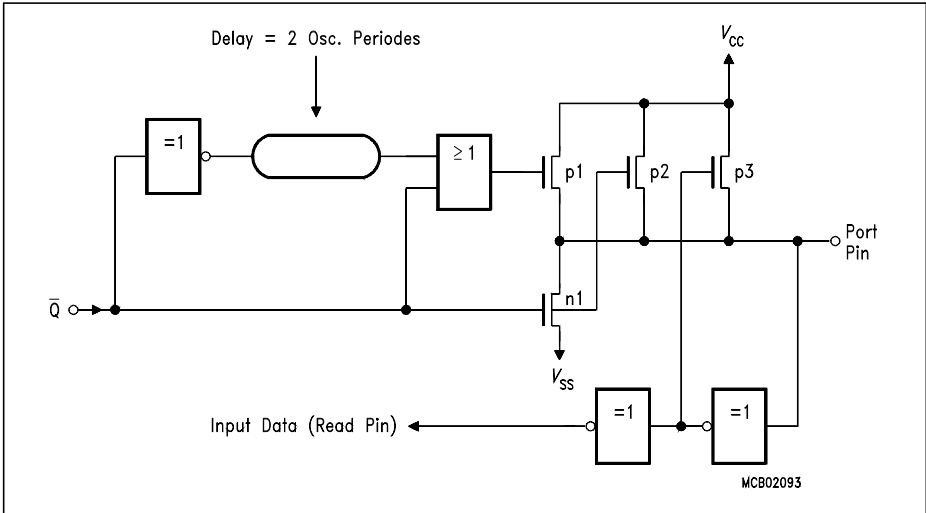

Figure 6-3
Output Driver Circuit of Ports 1, 2 and 3

- The **pulldown FET n1** is of n-channel type. It is a very strong driver transistor which is capable of sinking high currents (I_{OL}); it is only activated if a "0" is programmed to the port pin. A short circuit to V_{CC} must be avoided if the transistor is turned on, since the high current might destroy the FET.
- The **pullup FET p1** is of p-channel type. It is activated for two oscillator periods (S1P1 and S1P2) if a 0-to-1 transition is programmed to the port pin, i.e. a "1" is programmed to the port latch which contained a "0". The extra pullup can drive a similar current as the pulldown FET n1. This provides a fast transition of the logic levels at the pin.
- The **pullup FET p2** is of p-channel type. It is always activated when a "1" is in the port latch, thus providing the logic high output level. This pullup FET sources a much lower current than p1; therefore the pin may also be tied to ground, e.g. when used as input with logic low input level.
- The **pullup FET p3** is of p-channel type. It is only activated if the voltage at the port pin is higher than approximately 1.0 to 1.5 V. This provides an additional pullup current if a logic high level shall be output at the pin (and the voltage is not forced lower than approximately 1.0 to 1.5 V). However, this transistor is turned off if the pin is driven to a logic low level, e.g. when used as input. In this configuration only the weak pullup FET p2 is active, which sources the current I_{IL} . If, in addition, the pullup FET p3 is activated, a higher current can be sourced (I_{TL}). Thus, an additional power consumption can be avoided if port pins are used as inputs with a low level applied. However, the driving capability is stronger if a logic high level is output.

The described activating and deactivating of the four different transistors translates into four states the pins can be:

- input low state (IL), p2 active only
- input high state (IH) = steady output high state (SOH) p2 and p3 active
- forced output high state (FOH), p1, p2 and p3 active
- output low state (OL), n1 active

If a pin is used as input and a low level is applied, it will be in IL state, if a high level is applied, it will switch to IH state.

If the latch is loaded with "0", the pin will be in OL state.

If the latch holds a "0" and is loaded with "1", the pin will enter FOH state for two cycles and then switch to SOH state. If the latch holds a "1" and is reloaded with a "1" no state change will occur.

At the beginning of power-on reset the pins will be in IL state (latch is set to "1", voltage level on pin is below of the trip point of p3). Depending on the voltage level and load applied to the pin, it will remain in this state or will switch to IH (=SOH) state.

If it is used as output, the weak pull-up p2 will pull the voltage level at the pin above p3's trip point after some time and p3 will turn on and provide a strong "1". Note, however, that if the load exceeds the drive capability of p2 (I_{IL}), the pin might remain in the IL state and provide a weak "1" until the first 0-to-1 transition on the latch occurs. Until this the output level might stay below the trip point of the external circuitry.

The same is true if a pin is used as bidirectional line and the external circuitry is switched from output to input when the pin is held at "0" and the load then exceeds the p2 drive capabilities.

If the load exceeds I_{IL} the pin can be forced to "1" by writing a "0" followed by a "1" to the port pin.

Port 0, in contrast to ports 1, 2 and 3, is considered as "true" bidirectional, because the port 0 pins float when configured as inputs. Thus, this port differs in not having internal pullups. The pullup FET in the P0 output driver (**see figure 6-4a**) is used only when the port is emitting 1 s during the external memory accesses. Otherwise, the pullup is always off. Consequently, P0 lines that are used as output port lines are open drain lines. Writing a "1" to the port latch leaves both output FETs off and the pin floats. In that condition it can be used as high-impedance input. If port 0 is configured as general I/O port and has to emit logic high-level (1), external pullups are required.

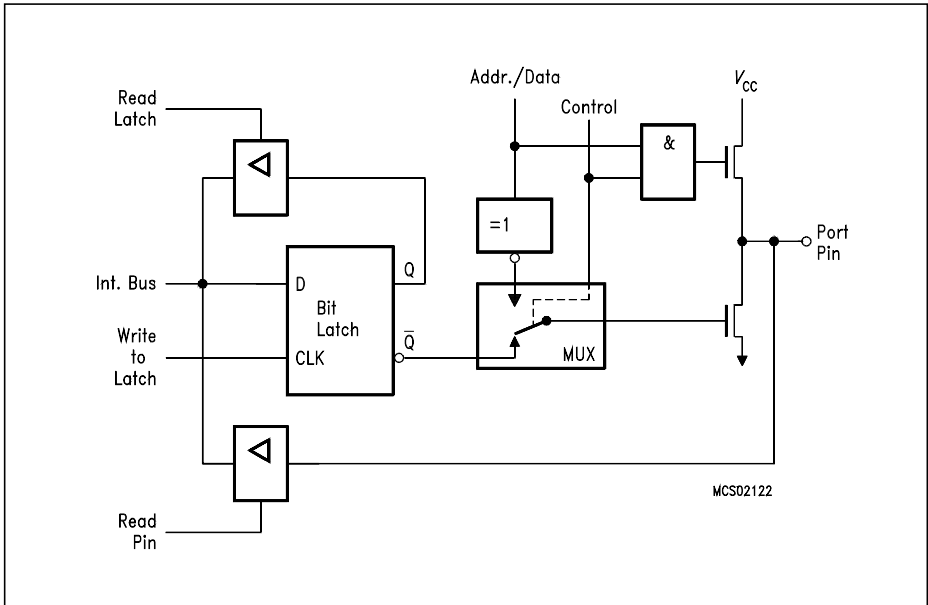

Figure 6-4a
Port 0 Circuitry

6.1.2 Port 0 and Port 2 used as Address/Data Bus

As shown in **figure 6-4a** and below in **figure 6-4b**, the output drivers of ports 0 and 2 can be switched to an internal address or address/data bus for use in external memory accesses. In this application they cannot be used as general purpose I/O, even if not all address lines are used externally. The switching is done by an internal control signal dependent on the input level at the $\bar{E}A$ pin and/or the contents of the program counter. If the ports are configured as an address/data bus, the port latches are disconnected from the driver circuit. During this time, the P0/P2 SFR remains unchanged. Being an address/data bus, port 0 uses a pullup FET as shown in **figure 6-4a**. When a 16-bit address is used, port 2 uses the additional strong pullups p1 to emit 1's for the entire external memory cycle instead of the weak ones (p2 and p3) used during normal port activity.

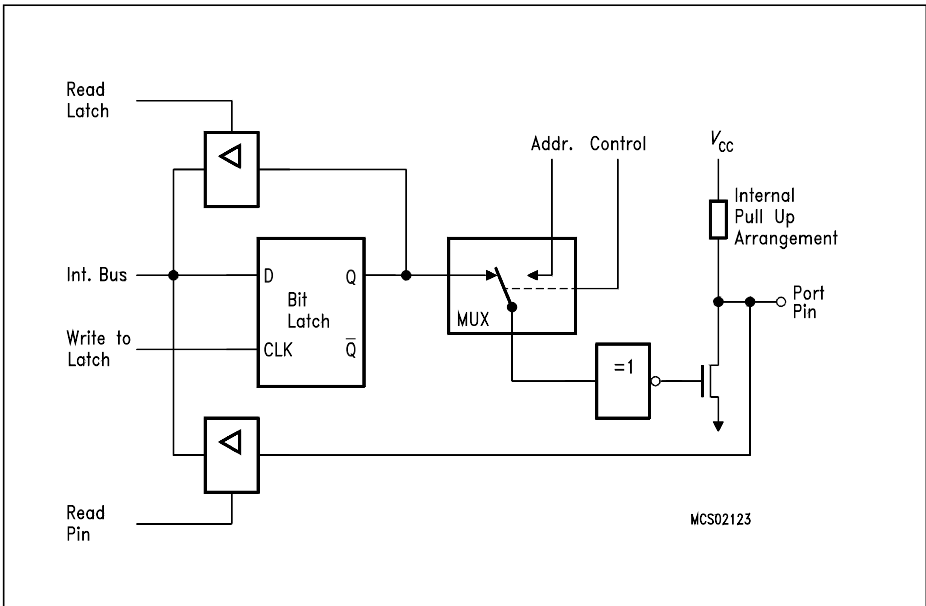

Figure 6-4b
Port 2 Circuitry

6.1.3 Alternate Functions

The pins of ports 1 and 3 are multifunctional. They are port pins and also serve to implement special features as listed in **table 6-1**.

Figure 6-5 shows a functional diagram of a port latch with alternate function. To pass the alternate function to the output pin and vice versa, however, the gate between the latch and driver circuit must be open. Thus, to use the alternate input or output functions, the corresponding bit latch in the port SFR has to contain a one (1); otherwise the pull-down FET is on and the port pin is stuck at 0. After reset all port latches contain ones (1).

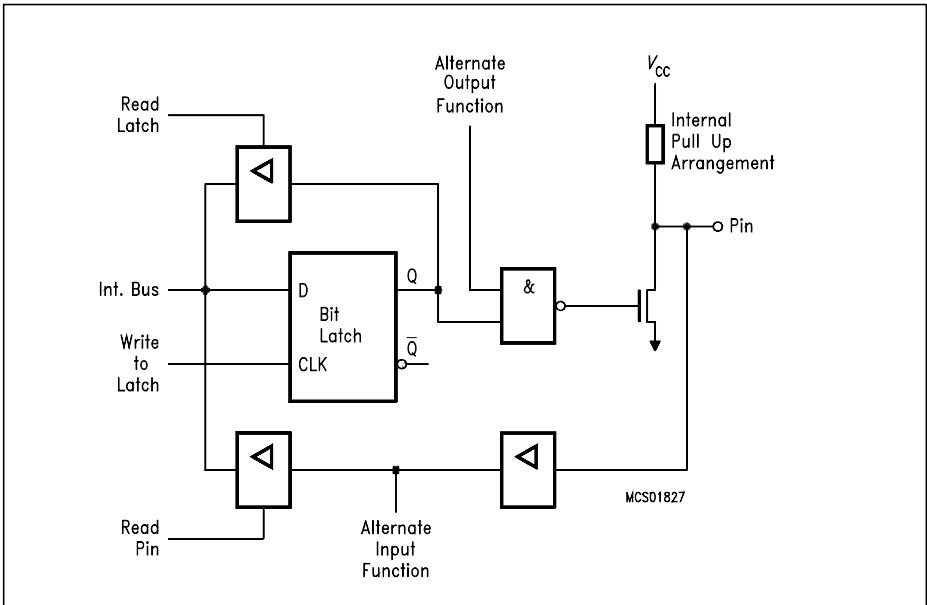

Figure 6-5
Ports 1 and 3

Ports 1 and 3 are provided for several alternate functions, as listed in **table 6-1**:

Table 6-1
Alternate Functions of Port 1 and 3

Port	Symbol	Function
P1.0	T2	Input to counter 2
P1.1	T2EX	Capture-reload trigger of timer 2 / up down count
P3.0	RxD	Serial port's receiver data input (asynchronous) or data input/output (synchronous)
P3.1	TxD	Serial port's transmitter data output (asynchronous) or data clock output (synchronous)
P3.2	$\overline{\text{INT0}}$	External interrupt 0 input, timer 0 gate control
P3.3	$\overline{\text{INT1}}$	External interrupt 1 input, timer 1 gate control
P3.4	T0	Timer 0 external counter input
P3.5	T1	Timer 1 external counter input
P3.6	$\overline{\text{WR}}$	External data memory write strobe
P3.7	$\overline{\text{RD}}$	External data memory read strobe

6.1.4 Port Handling

6.1.4.1 Port Timing

When executing an instruction that changes the value of a port latch, the new value arrives at the latch during S6P2 of the final cycle of the instruction. However, port latches are only sampled by their output buffers during phase 1 of any clock period (during phase 2 the output buffer holds the value it noticed during the previous phase 1). Consequently, the new value in the port latch will not appear at the output pin until the next phase 1, which will be at S1P1 of the next machine cycle.

When an instruction reads a value from a port pin (e.g. MOV A, P1) the port pin is actually sampled in state 5 phase 1 or phase 2 depending on port and alternate functions. **Figure 6-6** illustrates this port timing. It must be noted that this mechanism of sampling once per machine cycle is also used if a port pin is to detect an "edge", e.g. when used as counter input. In this case an "edge" is detected when the sampled value differs from the value that was sampled the cycle before. Therefore, there must be met certain requirements on the pulse length of signals in order to avoid signal "edges" not being detected. The minimum time period of high and low level is one machine cycle, which guarantees that this logic level is noticed by the port at least once.

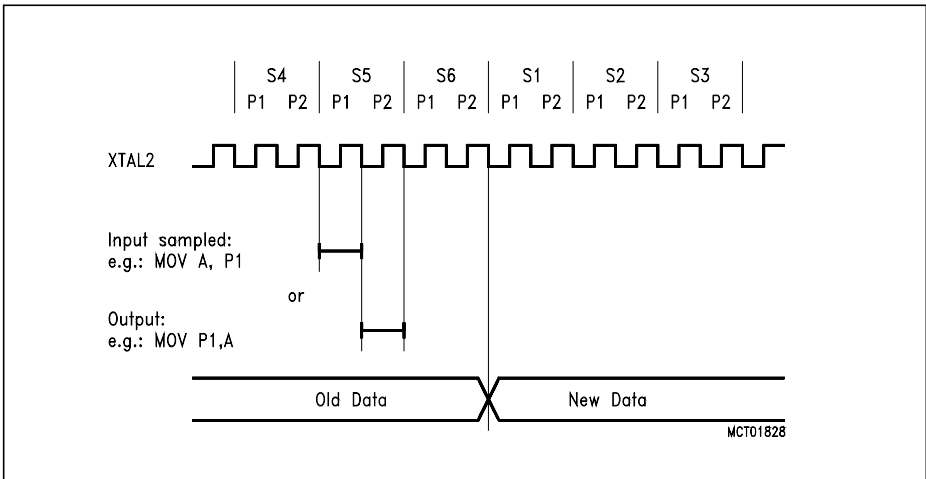

Figure 6-6
Port Timing

6.1.4.2 Port Loading and Interfacing

The output buffers of ports 1, 2 and 3 can drive TTL inputs directly. The maximum port load which still guarantees correct logic output levels can be looked up in the DC characteristics in the Data Sheet of the SAB-C501. The corresponding parameters are V_{OL} and V_{OH} .

The same applies to port 0 output buffers. They do, however, require external pullups to drive floating inputs, except when being used as the address/data bus.

When used as inputs it must be noted that the ports 1, 2 and 3 are not floating but have internal pullup transistors. The driving devices must be capable of sinking a sufficient current if a logic low level shall be applied to the port pin (the parameters I_{TL} and I_{IL} in the DC characteristics specify these currents). Port 0 has floating inputs when used for digital input.

6.1.4.3 Read-Modify-Write Feature of Ports 1, 2 and 3

Some port-reading instructions read the latch and others read the pin (**see figure 6-1**). The instructions reading the latch rather than the pin read a value, possibly change it, and then rewrite it to the latch. These are called "read-modify-write"-instructions, which are listed in **table 6-2**. If the destination is a port or a port pin, these instructions read the latch rather than the pin. Note that all other instructions which can be used to read a port, exclusively read the port pin. In any case, reading from latch or pin, resp., is performed by reading the SFR P0, P1, P2 and P3; for example, "MOV A, P3" reads the value from port 3 pins, while "ANL P3, #0AA_H" reads from the latch, modifies the value and writes it back to the latch.

It is not obvious that the last three instructions in **table 6-2** are read-modify-write instructions, but they are. The reason is that they read the port byte, all 8 bits, modify the addressed bit, then write the complete byte back to the latch.

Table 6-2
"Read-Modify-Write"-Instructions

Instruction	Function
ANL	Logic AND; e.g. ANL P1, A
ORL	Logic OR; e.g. ORL P2, A
XRL	Logic exclusive OR; e.g. XRL P3, A
JBC	Jump if bit is set and clear bit; e.g. JBC P1.1, LABEL
CPL	Complement bit; e.g. CPL P3.0
INC	Increment byte; e.g. INC P4
DEC	Decrement byte; e.g. DEC P5
DJNZ	Decrement and jump if not zero; e.g. DJNZ P3, EL
MOV Px.y,C	Move carry bit to bit y of port x
CLR Px.y	Clear bit y of port x
SETB Px.y	Set bit y of port x

The reason why read-modify-write instructions are directed to the latch rather than the pin is to avoid a possible misinterpretation of the voltage level at the pin. For example, a port bit might be used to drive the base of a transistor. When a "1" is written to the bit, the transistor is turned on. If the CPU then reads the same port bit at the pin rather than the latch, it will read the base voltage of the transistor (approx. 0.7 V, i.e. a logic low level!) and interpret it as "0". For example, when modifying a port bit by a SETB or CLR instruction, another bit in this port with the above mentioned configuration might be changed if the value read from the pin were written back to the latch. However, reading the latch rather than the pin will return the correct value of "1".

6.2 Timers/Counters

The SAB-C501 contains three 16-bit timers/counters which are useful in many applications for timing and counting.

In "timer" function, the register is incremented every machine cycle. Thus one can think of it as counting machine cycles. Since a machine cycle consists of 12 oscillator periods, the counter rate is $1/12$ of the oscillator frequency.

In "counter" function, the register is incremented in response to a 1-to-0 transition (falling edge) at its corresponding external input pin, T0 or T1 (alternate functions of P3.4 and P3.5, resp.). In this function the external input is sampled during S5P2 of every machine cycle. When the samples show a high in one cycle and a low in the next cycle, the count is incremented. The new count value appears in the register during S3P1 of the cycle following the one in which the transition was detected. Since it takes two machine cycles (24 oscillator periods) to recognize a 1-to-0 transition, the maximum count rate is $1/24$ of the oscillator frequency. There are no restrictions on the duty cycle of the external input signal, but to ensure that a given level is sampled at least once before it changes, it must be held for at least one full machine cycle.

6.2.1 Timer/Counter 0 and 1

Timer / counter 0 and 1 of the SAB-C501 are fully compatible with timer / counter 0 and 1 of the SAB 8051 and can be used in the same four operating modes:

Mode 0: 8-bit timer/counter with a divide-by-32 prescaler

Mode 1: 16-bit timer/counter

Mode 2: 8-bit timer/counter with 8-bit auto-reload

Mode 3: Timer/counter 0 is configured as one 8-bit timer/counter and one 8-bit timer; Timer/counter 1 in this mode holds its count. The effect is the same as setting TR1 = 0.

External inputs $\overline{\text{INT0}}$ and $\overline{\text{INT1}}$ can be programmed to function as a gate for timer/counters 0 and 1 to facilitate pulse width measurements.

Each timer consists of two 8-bit registers (TH0 and TL0 for timer/counter 0, TH1 and TL1 for timer/counter 1) which may be combined to one timer configuration depending on the mode that is established. The functions of the timers are controlled by two special function registers TCON and TMOD.

In the following descriptions the symbols TH0 and TL0 are used to specify the high-byte and the low-byte of timer 0 (TH1 and TL1 for timer 1, respectively). The operating modes are described and shown for timer 0. If not explicitly noted, this applies also to timer 1.

Special Function Register TCON (Address 88H)

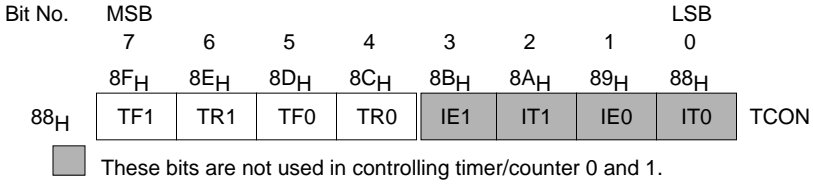

Bit	Function
TR0	Timer 0 run control bit. Set/cleared by software to turn timer/counter 0 ON/OFF.
TF0	Timer 0 overflow flag. Set by hardware on timer/counter overflow. Cleared by hardware when processor vectors to interrupt routine.
TR1	Timer 1 run control bit. Set/cleared by software to turn timer/counter 1 ON/OFF.
TF1	Timer 1 overflow flag. Set by hardware on timer/counter overflow. Cleared by hardware when processor vectors to interrupt routine.

Special Function Register TMOD (Address 89H)

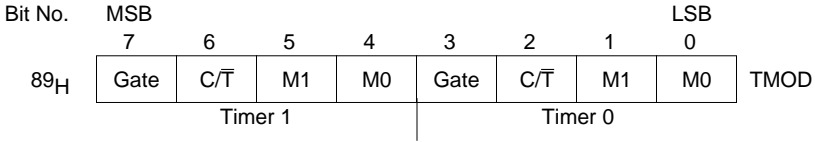

Timer/counter 0/1 mode control register.

Bit	Function															
Gate	Gating control. When set, timer/counter "x" is enabled only while "INT x" pin is high and "TRx" control bit is set. When cleared timer "x" is enabled whenever "TRx" control bit is set.															
C/T	Counter or timer select bit. Set for counter operation (input from "Tx" input pin). Cleared for timer operation (input from internal system clock).															
M1 M0	<table style="width: 100%; border-collapse: collapse;"> <tr> <td style="width: 50px; padding: 5px;">0</td> <td style="padding: 5px;">0</td> <td style="padding: 5px;">8-bit timer/counter. "THx" operates as 8-bit timer/counter "TLx" serves as 5-bit prescaler.</td> </tr> <tr> <td style="padding: 5px;">0</td> <td style="padding: 5px;">1</td> <td style="padding: 5px;">16-bit timer/counter. "THx" and "TLx" are cascaded; there is no prescaler.</td> </tr> <tr> <td style="padding: 5px;">1</td> <td style="padding: 5px;">0</td> <td style="padding: 5px;">8-bit auto-reload timer/counter. "THx" holds a value which is to be reloaded into "TLx" each time it overflows.</td> </tr> <tr> <td style="padding: 5px;">1</td> <td style="padding: 5px;">1</td> <td style="padding: 5px;">Timer 0: TL0 is an 8-bit timer/counter controlled by the standard timer 0 control bits. TH0 is an 8-bit timer only controlled by timer 1 control bits.</td> </tr> <tr> <td style="padding: 5px;">1</td> <td style="padding: 5px;">1</td> <td style="padding: 5px;">Timer 1: Timer/counter 1 stops</td> </tr> </table>	0	0	8-bit timer/counter. "THx" operates as 8-bit timer/counter "TLx" serves as 5-bit prescaler.	0	1	16-bit timer/counter. "THx" and "TLx" are cascaded; there is no prescaler.	1	0	8-bit auto-reload timer/counter. "THx" holds a value which is to be reloaded into "TLx" each time it overflows.	1	1	Timer 0: TL0 is an 8-bit timer/counter controlled by the standard timer 0 control bits. TH0 is an 8-bit timer only controlled by timer 1 control bits.	1	1	Timer 1: Timer/counter 1 stops
0	0	8-bit timer/counter. "THx" operates as 8-bit timer/counter "TLx" serves as 5-bit prescaler.														
0	1	16-bit timer/counter. "THx" and "TLx" are cascaded; there is no prescaler.														
1	0	8-bit auto-reload timer/counter. "THx" holds a value which is to be reloaded into "TLx" each time it overflows.														
1	1	Timer 0: TL0 is an 8-bit timer/counter controlled by the standard timer 0 control bits. TH0 is an 8-bit timer only controlled by timer 1 control bits.														
1	1	Timer 1: Timer/counter 1 stops														

6.2.1.1 Mode 0

Putting either timer/counter 0,1 into mode 0 configures it as an 8-bit timer/counter with a divide-by-32 prescaler. **Figure 6-7** shows the mode 0 operation.

In this mode, the timer register is configured as a 13-bit register. As the count rolls over from all 1's to all 0's, it sets the timer overflow flag TF0. The overflow flag TF0 then can be used to request an interrupt. The counted input is enabled to the timer when TR0 = 1 and either Gate = 0 or $\overline{\text{INT0}} = 1$ (setting Gate = 1 allows the timer to be controlled by external input $\overline{\text{INT0}}$, to facilitate pulse width measurements). TR0 is a control bit in the special function register TCON; Gate is in TMOD.

The 13-bit register consists of all 8 bits of TH0 and the lower 5 bits of TL0. The upper 3 bits of TL0 are indeterminate and should be ignored. Setting the run flag (TR0) does not clear the registers.

Mode 0 operation is the same for timer 0 as for timer 1. Substitute TR0, TF0, TH0, TL0 and $\overline{\text{INT0}}$ for the corresponding timer 1 signals in **figure 6-7**. There are two different gate bits, one for timer 1 (TMOD.7) and one for timer 0 (TMOD.3).

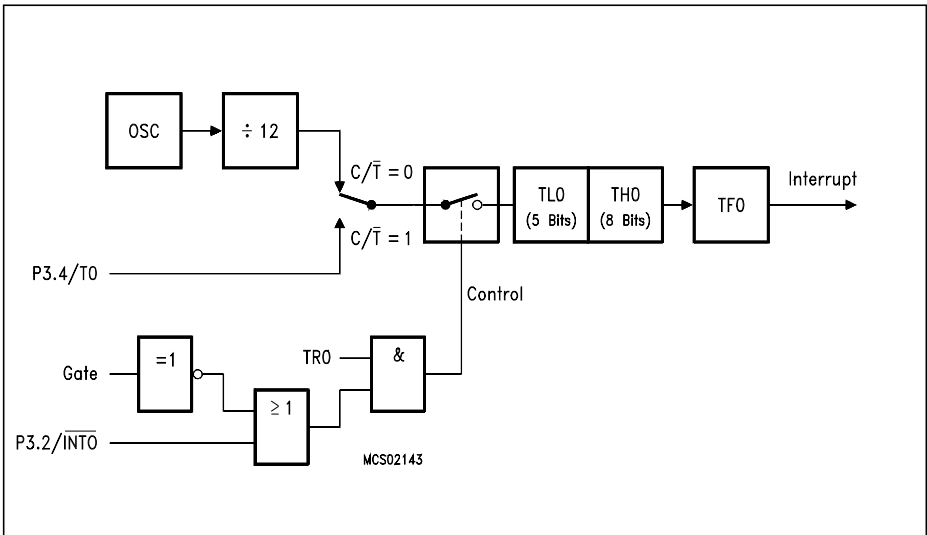

Figure 6-7
Timer/Counter 0, Mode 0: 13-Bit Timer/Counter

6.2.1.2 Mode 1

Mode 1 is the same as mode 0, except that the timer register is running with all 16 bits.

Mode 1 is shown in figure 6-8.

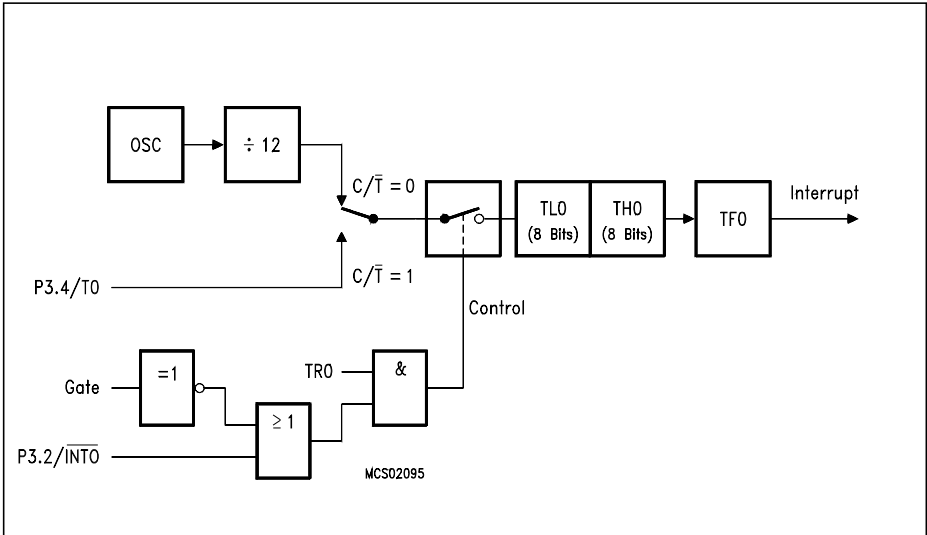

Figure 6-8
Timer/Counter 0, Mode 1: 16-Bit Timer/Counter

6.2.1.3 Mode 2

Mode 2 configures the timer register as an 8-bit counter (TL0) with automatic reload, as shown in figure 6-9. Overflow from TL0 not only sets TF0, but also reloads TL0 with the contents of TH0, which is preset by software. The reload leaves TH0 unchanged.

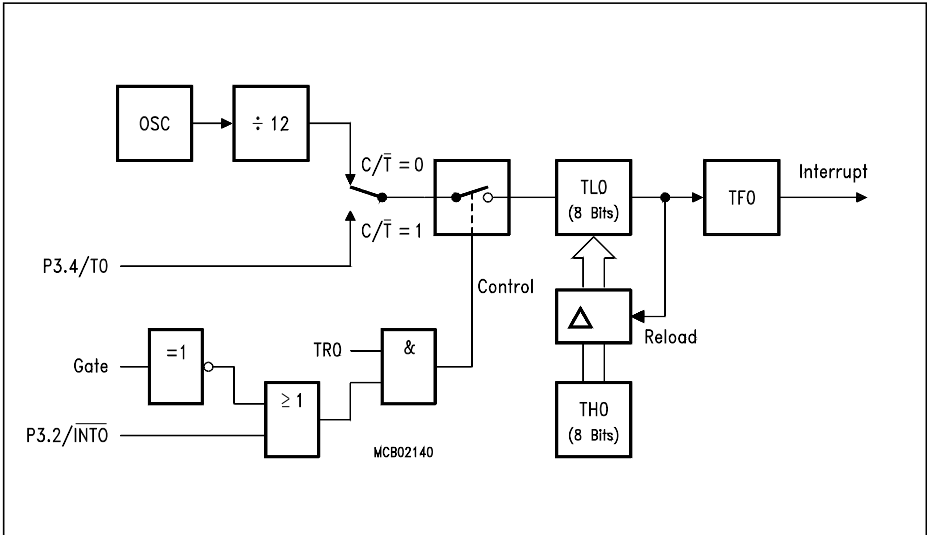

Figure 6-9
Timer/Counter 0,1, Mode 2: 8-Bit Timer/Counter with Auto-Reload

6.2.1.4 Mode 3

Mode 3 has different effects on timer 0 and timer 1. Timer 1 in mode 3 simply holds its count. The effect is the same as setting TR1=0. Timer 0 in mode 3 establishes TL0 and TH0 as two separate counters. The logic for mode 3 on timer 0 is shown in **figure 6-10**. TL0 uses the timer 0 control bits: C/T, Gate, TR0, INT0 and TF0. TH0 is locked into a timer function (counting machine cycles) and takes over the use of TR1 and TF1 from timer 1. Thus, TH0 now controls the "timer 1" interrupt.

Mode 3 is provided for applications requiring an extra 8-bit timer or counter. When timer 0 is in mode 3, timer 1 can be turned on and off by switching it out of and into its own mode 3, or can still be used by the serial channel as a baud rate generator, or in fact, in any application not requiring an interrupt from timer 1 itself.

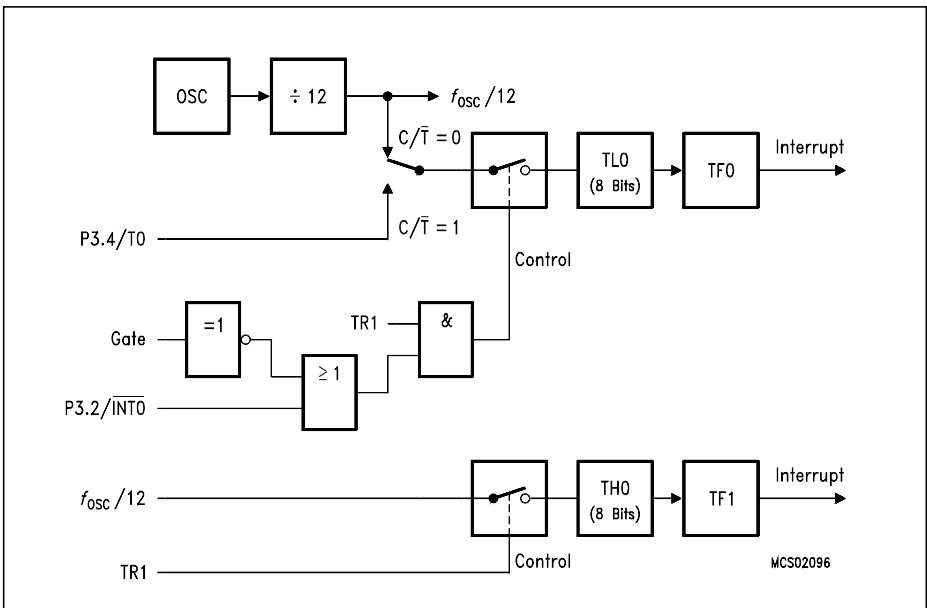

Figure 6-10
Timer/Counter 0, Mode 3: Two 8-Bit Timers/Counters

6.2.2 Timer/Counter 2

Timer 2 is a 16-bit timer / counter which can operate as timer or counter. It has three operating modes:

- 16-bit auto-reload mode (up or down counting)
- 16-bit capture mode
- Baudrate generator (see 6.3.2.2 Serial Interface)

The modes are selected by bits in the SFR T2CON (C8H) as shown in **table 6-3**:

**Table 6-3
Timer/Counter 2 - Operating Modes**

RXCLK + TXCLK	CP/RL2	TR2	Mode
0	0	1	16-bit auto-reload
0	1	1	16-bit capture
1	X	1	Baud rate generator
X	X	0	(OFF)

Timer 2 consists of two 8-bit registers, TH2 and TL2. In the timer function, the TL2 register is incremented every machine cycle. Since a machine cycle consists of 12 oscillator periods, the count rate is 1/12 of the oscillator frequency.

In the counter function, the register is incremented in response to a 1-to-0 transition at its corresponding external input pin, T2 (P1.0). In this function, the external input is sampled during S5P2 of every machine cycle. When the samples show a high in one cycle and a low in the next cycle, the count is incremented. The new value appears in the register during S3P1 of the cycle following the one in which the transition was detected. Since it takes two machine cycles to recognize a 1-to-0 transition, the maximum count rate is 1/24 of the oscillator frequency. To ensure that a given level is sampled at least once before it changes, it should be held for at least one full machine cycle.

Special Function Register T2CON (Address C8_H)

Bit No.	MSB							LSB		T2CON
	7	6	5	4	3	2	1	0		
C8 _H	TF2	EXF2	RCLK	TCLK	EXEN2	TR2	C/T ₂	CP/RL ₂		

Bit	Function
TF2	Timer 2 Overflow Flag. Set by a timer 2 overflow. Must be cleared by software. TF2 will not be set when either RCLK = 1 or TCLK = 1.
EXF2	Timer 2 External Flag. Set when either a capture or reload is caused by a negative transition on T2EX and EXEN2 = 1. When timer 2 interrupt is enabled, EXF2 = 1 will cause the CPU to vector to the timer 2 interrupt routine. EXF2 must be cleared by software. EXF2 does not cause an interrupt in up/down counter mode (DCEN = 1, SFR T2MOD)
RCLK	Receive Clock Enable. When set, causes the serial port to use timer 2 overflow pulses for its receive clock in serial port modes 1 and 3. RCLK = 0 causes timer 1 overflows to be used for the receive clock.
TCLK	Transmit Clock Enable. When set, causes the serial port to use timer 2 overflow pulses for its transmit clock in serial port modes 1 and 3. TCLK = 0 causes timer 1 overflow to be used for the transmit clock.
EXEN2	Timer 2 External Enable. When set, allows a capture or reload to occur as a result of a negative transition on pin T2EX (P1.1) if timer 2 is not being used to clock the serial port. EXEN2 = 0 causes timer 2 to ignore events at T2EX.
TR2	Start / Stop Control for Timer 2. TR2 = 1 starts timer 2.
C/T ₂	Timer or Counter Select for Timer 2. C/T ₂ = 0 for timer function. C/T ₂ = 1 for external event counter (falling edge triggered).
CP/RL ₂	Capture /Reload Select. CP/RL ₂ = 1 causes captures to occur on negative transitions at pin T2EX if EXEN2 = 1. CP/RL ₂ = 0 causes automatic reloads to occur when timer 2 overflows or negative transitions occur at pin T2EX when EXEN2 = 1. When either RCLK = 1 or TCLK = 1, this bit is ignored and the timer is forced to auto-reload on timer 2 overflow.

The reset value of T2CON is 00_H.

6.2.2.1 Auto-Reload (Up or Down Counter)

Timer 2 can be programmed to count up or down when configured in its 16-bit auto-reload mode. This feature is invoked by a bit named DCEN (Down Counter Enable, SFR T2MOD, 0C9_H). When DCEN is set, timer 2 can count up or down depending on the value of pin T2EX (P1.1).

Special Function Register T2MOD (Address C9_H)

Bit No.	MSB							LSB	
	7	6	5	4	3	2	1	0	
C9 _H	-	-	-	-	-	-	-	DCEN	T2MOD

Bit	Function
-	Not implemented, reserved for future use.
DCEN	When set, this bit allows timer 2 to be configured as an up/down counter.

Reset value of T2MOD is XXXX XXX0_B.

Figure 6-11 shows timer 2 automatically counting up when DCEN = 0. In this mode there are two options selectable by bit EXEN2 in SFR T2CON.

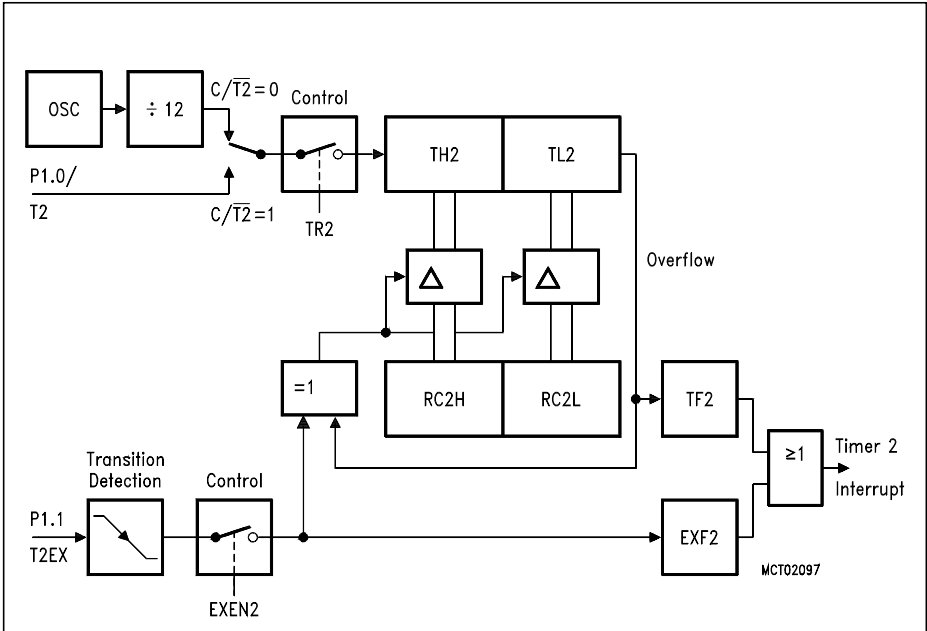

Figure 6-11
Timer 2 Auto-Reload Mode (DCEN = 0)

If EXEN2 = 0, timer 2 counts up to $FFFF_H$ and then sets the TF2 bit upon overflow. The overflow also causes the timer registers to be reloaded with the 16-bit value in RC2H and RC2L. The values in RC2H and RC2L are preset by software.

If EXEN2 = 1, a 16-bit reload can be triggered either by an overflow or by a 1-to-0 transition at the external input T2EX (P1.1). This transition also sets the EXF2 bit. Both the TF2 and EXF2 bits can generate a timer 2 interrupt if enabled.

Setting the DCEN bit enables timer 2 to count up or down as shown in **figure 6-12**. In this mode the T2EX pin controls the direction of count.

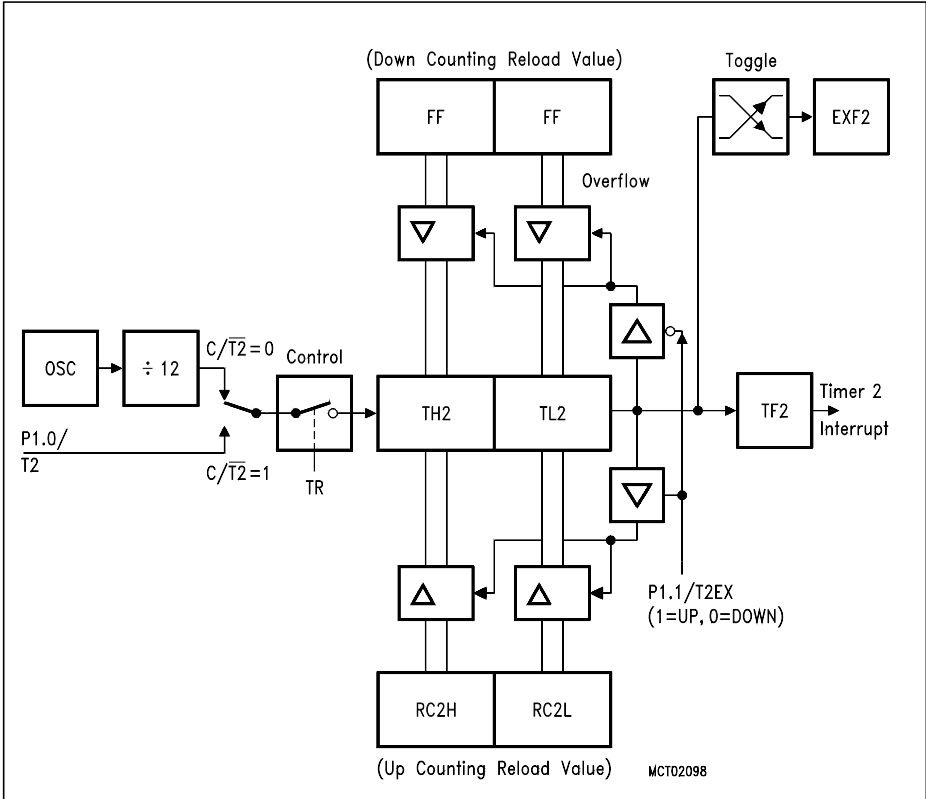

Figure 6-12
Timer 2 Auto-Reload Mode (DCEN = 1)

A logic 1 at T2EX makes timer 2 count up. The timer will overflow at FFFF_H and set the TF2 bit. This overflow also causes the 16-bit value in RC2H and RC2L to be reloaded into the timer registers, TH2 and TL2, respectively.

A logic 0 at T2EX makes timer 2 count down. Now the timer underflows when TH2 and TL2 equal the values stored in RC2H and RC2L. The underflow sets the TF2 bit and causes FFFF_H to be reloaded into the timer registers. The EXF2 bit toggles whenever timer 2 overflows or underflows. This bit can be used as a 17th bit of resolution if desired. In this operating mode, EXF2 does not flag an interrupt.

Note: P1.1/T2EX is sampled during S5P2 of every machine cycle. The next increment/decrement of timer 2 will be done during S3P1 in the next cycle.

6.2.2.2 Capture

In the capture mode there are two options selected by bit EXEN2 in SFR T2CON.

If EXEN2 = 0, timer 2 is a 16-bit timer or counter which upon overflow sets bit TF2 in SFR T2CON. This bit can be used to generate an interrupt.

If EXEN2 = 1, timer 2 still does the above, but with added feature that a 1-to-0 transition at external input T2EX causes the current value in TH2 and TL2 to be captured into RC2H and RC2L, respectively. In addition, the transition at T2EX causes bit EXF2 in SFR T2CON to be set. The EXF2 bit, like TF2, can generate an interrupt. The capture mode is illustrated in **figure 6-13**.

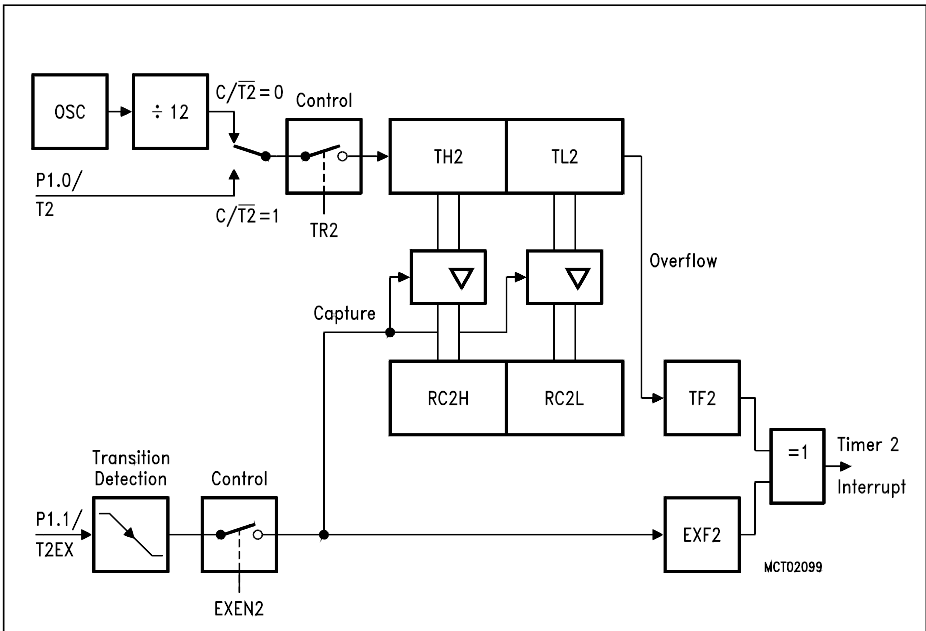

Figure 6-13
Timer 2 in Capture Mode

The baud rate generator mode is selected by RCLK = 1 and/or TCLK = 1 in SFR T2CON. It will be described in conjunction with the serial port.

6.3 Serial Interface (USART)

The serial port is full duplex, meaning it can transmit and receive simultaneously. It is also receive-buffered, meaning it can commence reception of a second byte before a previously received byte has been read from the receive register. (However, if the first byte still hasn't been read by the time reception of the second byte is complete, one of the bytes will be lost). The serial port receive and transmit registers are both accessed at special function register SBUF. Writing to SBUF loads the transmit register, and reading SBUF accesses a physically separate receive register.

The serial port can operate in 4 modes (one synchronous mode, three asynchronous modes):

Mode 0, Shift Register (Synchronous) Mode:

Serial data enters and exits through RXD. TXD outputs the shift clock. 8 data bits are transmitted/received: (LSB first). The baud rate is fixed at $1/12$ of the oscillator frequency. (See section 6.3.3 for more detailed information)

Mode 1, 8-Bit USART, Variable Baud Rate:

10 bits are transmitted (through TXD) or received (through RXD): a start bit (0), 8 data bits (LSB first), and a stop bit (1). On receive, the stop bit goes into RB8 in special function register SCON. The baud rate is variable. (See section 6.3.4 for more detailed information)

Mode 2, 9-Bit USART, Fixed Baud Rate:

11 bits are transmitted (through TXD) or received (through RXD): a start bit (0), 8 data bits (LSB first), a programmable 9th data bit, and a stop bit (1). On transmit, the 9th data bit (TB8 in SCON) can be assigned to the value of 0 or 1. Or, for example, the parity bit (P, in the PSW) could be moved into TB8. On receive, the 9th data bit goes into RB8 in special function register SCON, while the stop bit is ignored. The baud rate is programmable to either $1/32$ or $1/64$ of the oscillator frequency. (See section 6.3.5 for more detailed information)

Mode 3, 9-Bit USART, Variable Baud Rate:

11 bits are transmitted (through TXD) or received (through RXD): a start bit (0), 8 data bits (LSB first), a programmable 9th data bit, and a stop bit (1). In fact, mode 3 is the same as mode 2 in all respects except the baud rate. The baud rate in mode 3 is variable. (See section 6.3.5 for more detailed information)

In all four modes, transmission is initiated by any instruction that uses SBUF as a destination register. Reception is initiated in mode 0 by the condition $RI = 0$ and $REN = 1$. Reception is initiated in the other modes by the incoming start bit if $REN = 1$.

6.3.1 Multiprocessor Communications

Modes 2 and 3 have a special provision for multiprocessor communications. In these modes, 9 data bits are received. The 9th one goes into RB8. Then comes a stop bit. The port can be programmed such that when the stop bit is received, the serial port interrupt will be activated only if RB8 = 1. This feature is enabled by setting bit SM2 in SCON. A way to use this feature in multiprocessor systems is as follows.

When the master processor wants to transmit a block of data to one of several slaves, it first sends out an address byte which identifies the target slave. An address byte differs from a data byte in that the 9th bit is 1 in an address byte and 0 in a data byte. With SM2 = 1, no slave will be interrupted by a data byte. An address byte, however, will interrupt all slaves, so that each slave can examine the received byte and see if it is being addressed. The addressed slave will clear its SM2 bit and prepare to receive the data bytes that will be coming. The slaves that weren't being addressed leave their SM2s set and go on about their business, ignoring the incoming data bytes.

SM2 has no effect in mode 0, and in mode 1 can be used to check the validity of the stop bit. In a mode 1 reception, if SM2 = 1, the receive interrupt will not be activated unless a valid stop bit is received.

Serial Port Control Register

The serial port control and status register is the special function register SCON. This register contains not only the mode selection bits, but also the 9th data bit for transmit and receive (TB8 and RB8), and the serial port interrupt bits (TI and RI).

Special Function Register SCON (Address 98H)

Bit No.	MSB								LSB	
	7	6	5	4	3	2	1	0		
98H	SM0	SM1	SM2	REN	TB8	RB8	TI	RI	SCON	

Bit	Function
SM0 SM1	
0 0	Serial mode 0: Shift register, fixed baud rate ($f_{osc}/12$)
0 1	Serial mode 1: 8-bit UART, variable baud rate
1 0	Serial mode 2: 9-bit UART, fixed baud rate ($f_{osc}/64$ or $f_{osc}/32$)
1 1	Serial mode 3: 9-bit UART, variable baud rate
SM2	Enables the multiprocessor communication feature in modes 2 and 3. In mode 2 or 3, if SM2 is set to 1 then RI will not be activated if the received 9th data bit (RB8) is 0. In mode 1, if SM2 = 1 then RI will not be activated if a valid stop bit was not received. In mode 0, SM2 should be 0.
REN	Enables serial reception. Set by software to enable reception. Clear by software to disable reception.
TB8	Is the 9th data bit that will be transmitted in modes 2 and 3. Set or clear by software as desired.
RB8	In modes 2 and 3, is the 9th data bit that was received. In mode 1, if SM2 = 0, RB8 is the stop bit that was received. In mode 0, RB8 is not used.
TI	Is transmit interrupt flag. Set by hardware at the end of the 8th bit time in mode 0, or at the beginning of the stop bit in the other modes, in any serial transmission. Must be cleared by software.
RI	Is receive interrupt flag. Set by hardware at the end of the 8th bit time in mode 0, or halfway through the stop bit time in the other modes, in any serial reception (except see SM2). Must be cleared by software.

6.3.2 Baud Rates

There are several possibilities to generate the baud rate clock for the serial interface depending on the mode in which it is operated.

To clarify the terminology, something should be said about the differences between "baud rate clock" and "baud rate".

The serial interface requires a clock rate which is 16 times the baud rate for the internal synchronization. Therefore, the baud rate generators have to provide a "baud rate clock" to the serial interface which - there divided by 16 - results in the actual "baud rate".

However, all formulas given in the following section already include the factor and calculate the final baud rate.

Mode 0

The baud rate in mode 0 is fixed:

$$\text{Mode 0 baud rate} = \text{oscillator frequency}/12 = f_{\text{osc}}/12$$

Mode 2

The baud rate in mode 2 depends on the value of bit SMOD in special function register PCON (87_H). If SMOD = 0 (which is the value on reset), the baud rate is $f_{\text{osc}}/64$. If SMOD = 1, the baud rate is $f_{\text{osc}}/32$.

$$\text{Mode 2 baud rate} = 2^{\text{SMOD}}/64 \times (f_{\text{osc}})$$

Modes 1 and 3

The baud rates in mode 1 and 3 are determined by the timer overflow rate. These baud rates can be determined by timer 1 or by timer 2 or by both (one for transmit and the other for receive).

6.3.2.1 Using Timer 1 to Generate Baud Rates

When timer 1 is used as the baud rate generator, the baud rates in modes 1 and 3 are determined by the timer 1 overflow rate and the value of SMOD as follows:

$$\text{Modes 1,3 baud rate} = 2^{\text{SMOD}}/32 \times (\text{timer 1 overflow rate})$$

The timer 1 interrupt should be disabled in this application. The timer itself can be configured for either "timer" or "counter" operation, and in any of its 3 running modes. In the most typical applications, it is configured for "timer" operation, in the auto-reload mode (high nibble of TMOD=0010B). In that case, the baud rate is given by the formula

$$\text{Modes 1,3 baud rate} = 2^{\text{SMOD}}/32 \times f_{\text{osc}}/[12 \times (256 - \text{TH1})]$$

One can achieve very low baud rates with timer 1 by leaving the timer 1 interrupt enabled, and configuring the timer to run as a 16-bit timer (high nibble of TMOD = 0001B), and using the timer 1 interrupt to do a 16-bit software reload.

Table 6-4 lists commonly used baud rates and how they can be obtained from timer 1.

**Table 6-4
Timer 1 Generated Commonly Used Baud Rates**

Baud Rate	f_{osc}	SMOD	Timer 1		
			C/T	Mode	Reload Value
Mode 0 max: 1 MHz	12 MHz	X	X	X	X
Mode 2 max: 375 K	12 MHz	1	X	X	X
Modes 1, 3: 62.5 K	12 MHz	1	0	2	FF _H
19.2 K	11.059 MHz	1	0	2	FD _H
9.6 K	11.059 MHz	0	0	2	FD _H
4.8 K	11.059 MHz	0	0	2	FA _H
2.4 K	11.059 MHz	0	0	2	F4 _H
1.2 K	11.059 MHz	0	0	2	E8 _H
110	6 MHz	0	0	2	72 _H
110	12 MHz	0	0	1	FEEB _H

6.3.2.2 Using Timer 2 to Generate Baud Rates

Timer 2 is selected as the baud rate generator by setting TCLK and/or RCLK in T2CON. Note then the baud rates for transmit and receive can be simultaneously different. Setting RCLK and/or TCLK puts timer 2 into its baud rate generator mode, as shown in figure 6-14.

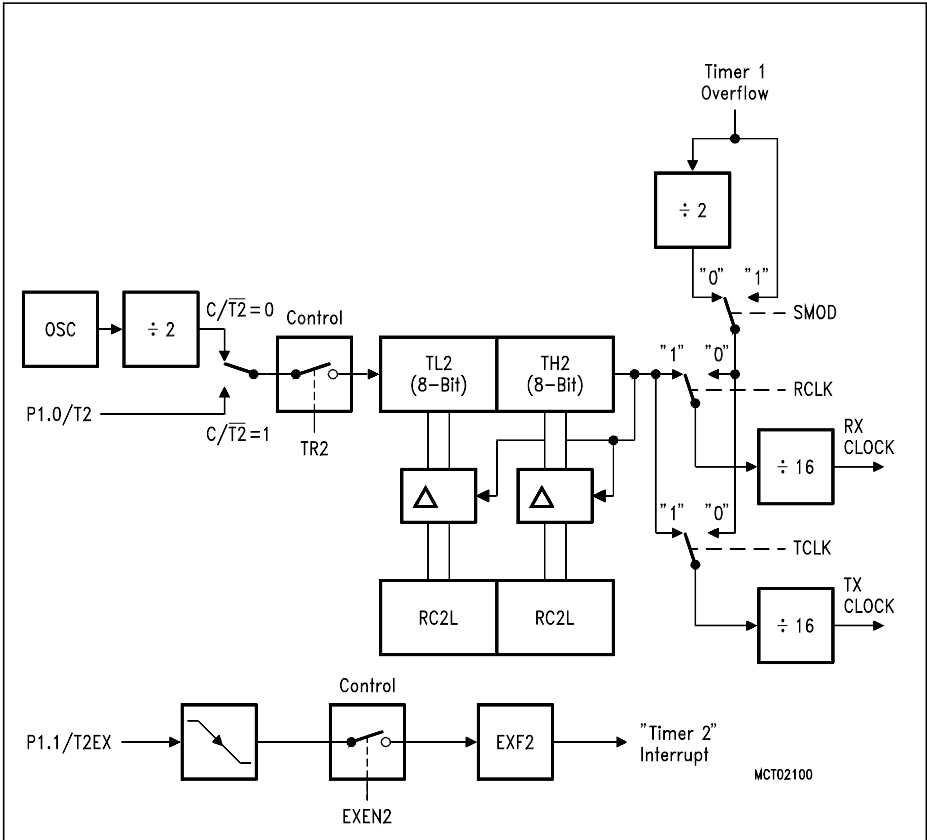

Figure 6-14
Timer 2 in Baud Rate Generator Mode

The baud rate generator mode is similar to the auto-reload mode, in that rollover in TH2 causes the timer 2 registers to be reloaded with the 16-bit value in registers RC2H and RC2L, which are preset by software.

Now the baud rates in modes 1 and 3 are determined by timer 2's overflow rate as follows:

$$\text{Modes 1, 3 baud rate} = \text{timer 2 overflow rate}/16$$

The timer can be configured for either "timer" or "counter" operation: In the most typical applications, it is configured for "timer" operation ($C/\overline{T2} = 0$). "Timer" operation is a little different for timer 2 when it's being used as a baud rate generator. Normally, as a timer it would increment every machine cycle (thus at $f_{osc}/12$). As a baud rate generator, however, it increments every state time ($f_{osc}/2$). In that case the baud rate is given by the formula

$$\text{Modes 1,3 baud rate} = f_{osc}/32 \times [65536 - (\text{RC2H}, \text{RC2L})]$$

where (RC2H, RC2L) is the content of RC2H and RC2L taken as a 16-bit unsigned integer.

Note that the rollover in TH2 does not set TF2, and will not generate an interrupt. Therefore, the timer 2 interrupt does not have to be disabled when timer 2 is in the baud rate generator mode. Note too, that if EXEN2 is set, a 1-to-0 transition in T2EX can be used as an extra external interrupt, if desired.

It should be noted that when timer 2 is running ($\text{TR2} = 1$) in "timer" function in the baud rate generator mode, one should not try to read or write TH2 or TL2. Under these conditions the timer is being incremented every state time, and the results of a read or write may not be accurate. The RC registers may be read, but shouldn't be written to, because a write might overlap a reload and cause write and/or reload errors. Turn the timer off (clear TR2) before accessing the timer 2 or RC registers, in this case.

6.3.3 Details about Mode 0

Serial data enters and exists through RXD. TXD outputs the shift clock. 8 data bits are transmitted/received: (LSB first). The baud rate is fixed at $f_{osc}/12$.

Figure 6-15a shows a simplified functional diagram of the serial port in mode 0. The associated timing is illustrated in **figure 6-15b**.

Transmission is initiated by any instruction that uses SBUF as a destination register. The "WRITE to SBUF" signal at S6P2 also loads a 1 into the 9th position of the transmit shift register and tells the TX control block to commence a transmission. The internal timing is such that one full machine cycle will elapse between "WRITE to SBUF", and activation of SEND.

SEND enables the output of the shift register to the alternate output function line of P3.0, and also enables SHIFT CLOCK to the alternate output function line of P3.1. SHIFT CLOCK is low during S3, S4, and S5 of every machine cycle, and high during S6, S1 and S2. At S6P2 of every machine cycle in which SEND is active, the contents of the transmit shift register are shifted to the right one position.

As data bits shift out to the right, zeroes come in from the left. When the MSB of the data byte is at the output position of the shift register, then the 1 that was initially loaded into the 9th position, is just to the left of the MSB, and all positions to the left of that contain zeroes. This condition flags the TX control block to do one last shift and then deactivate SEND and set TI. Both of these actions occur at S1P1 of the 10th machine cycle after "WRITE to SBUF".

Reception is initiated by the condition REN = 1 and R1 = 0. At S6P2 of the next machine cycle, the RX control unit writes the bits 1111 1110 to the receive shift register, and in the next clock phase activates RECEIVE.

RECEIVE enables SHIFT CLOCK to the alternate output function line of P3.1. SHIFT CLOCK makes transitions at S3P1 and S6P1 of every machine cycle. At S6P2 of every machine cycle in which RECEIVE is active, the contents of the receive shift register are shifted to the left one position. The value that comes in from the right is the value that was sampled at the P3.0 pin at S5P2 of the same machine cycle.

As data bit comes in from the right, 1s shift out to the left. When the 0 that was initially loaded into the rightmost position arrives at the leftmost position in the shift register, it flags the RX control block to do one last shift and load SBUF. At S1P1 of the 10th machine cycle after the write to SCON that cleared RI, RECEIVE is cleared and RI is set.

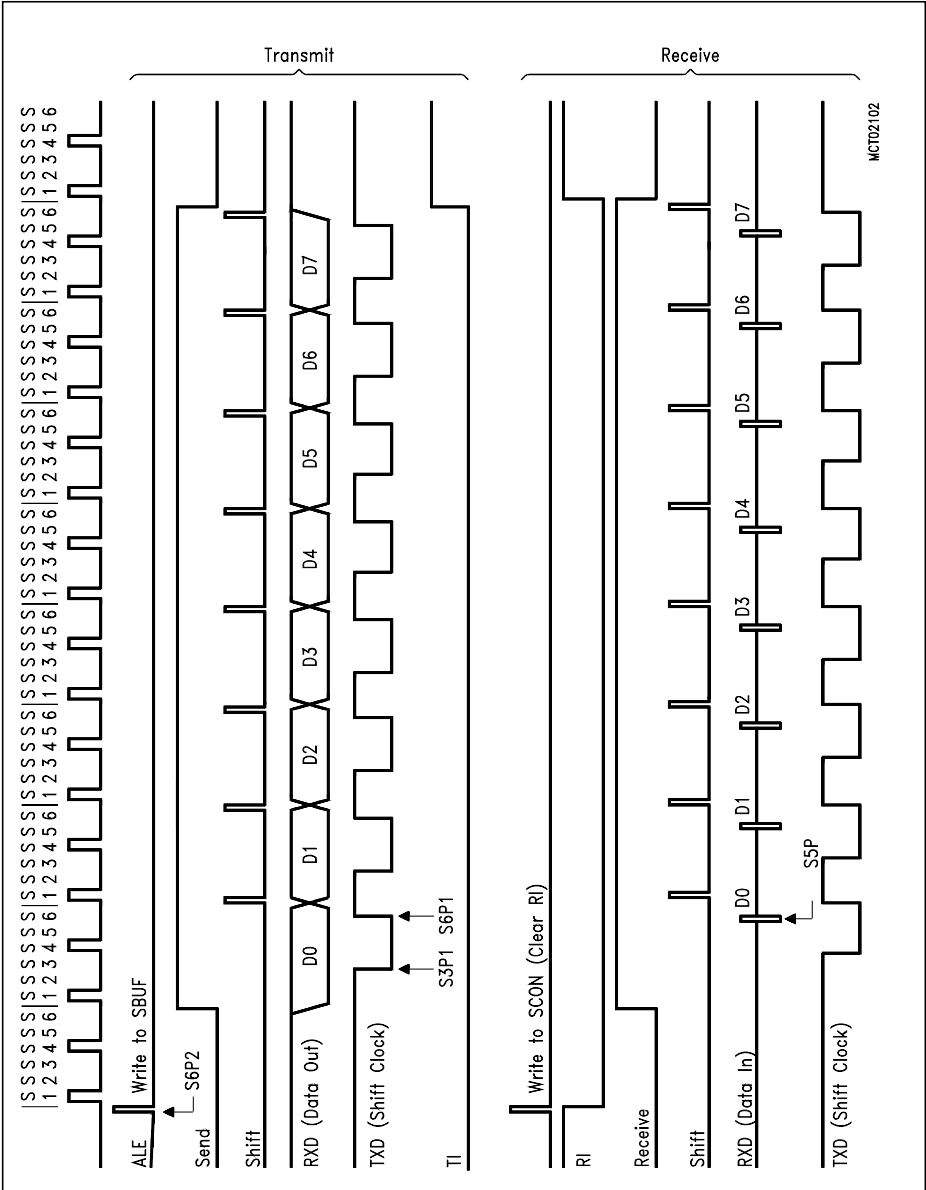

Figure 6-15b
Serial Interface, Mode 0, Timing Diagram

6.3.4 Details about Mode 1

Ten bits are transmitted (through TXD), or received (through RXD): a start bit (0), 8 data bits (LSB first), and a stop bit (1). On receive, the stop bit goes into RB8 in SCON. The baud rate is determined either by the timer 1 overflow rate, or the timer 2 overflow rate, or both (one for transmit and the other for receive).

Figure 6-16a shows a simplified functional diagram of the serial port in mode 1. The associated timings for transmit receive are illustrated in **figure 6-16b**.

Transmission is initiated by an instruction that uses SBUF as a destination register. The "WRITE to SBUF" signal also loads a 1 into the 9th bit position of the transmit shift register and flags the TX control unit that a transmission is requested. Transmission starts at the next rollover in the divide-by-16 counter. (Thus, the bit times are synchronized to the divide-by-16 counter, not to the "WRITE to SBUF" signal).

The transmission begins with activation of $\overline{\text{SEND}}$, which puts the start bit at TXD. One bit time later, DATA is activated, which enables the output bit of the transmit shift register to TXD. The first shift pulse occurs one bit time after that.

As data bits shift out to the right, zeroes are clocked in from the left. When the MSB of the data byte is at the output position of the shift register, then the 1 that was initially loaded into the 9th position is just to the left of the MSB, and all positions to the left of that contain zeroes. This condition flags the TX control unit to do one last shift and then deactivate $\overline{\text{SEND}}$ and set TI. This occurs at the 10th divide-by-16 rollover after "WRITE to SBUF".

Reception is initiated by a detected 1-to-0 transition at RXD. For this purpose RXD is sampled at a rate of 16 times whatever baud rate has been established. When a transition is detected, the divide-by-16 counter is immediately reset, and 1FH is written into the input shift register, and reception of the rest of the frame will proceed.

The 16 states of the counter divide each bit time into 16ths. At the 7th, 8th and 9th counter states of each bit time, the bit detector samples the value of RXD. The value accepted is the value that was seen in at latest 2 of the 3 samples. This is done for the noise rejection. If the value accepted during the first bit time is not 0, the receive circuits are reset and the unit goes back to looking for another 1-to-0 transition. This is to provide rejection or false start bits. If the start bit proves valid, it is shifted into the input shift register, and reception of the rest of the frame will proceed.

As data bits come in from the right, 1s shift out to the left. When the start bit arrives at the leftmost position in the shift register, (which in mode 1 is a 9-bit register), it flags the RX control block to do one last shift, load SBUF and RB8, and set RI. The signal to load SBUF and RB8, and to set RI, will be generated if, and only if, the following conditions are met at the time the final shift pulse is generated.

- 1) RI = 0, and
- 2) Either SM2 = 0, or the received stop bit = 1

If either of these two conditions is not met, the received frame is irretrievably lost. If both conditions are met, the stop bit goes into RB8, the 8 data bit goes into SBUF, and RI is activated. At this time, whether the above conditions are met or not, the unit goes back to looking for a 1-to-0 transition in RXD.

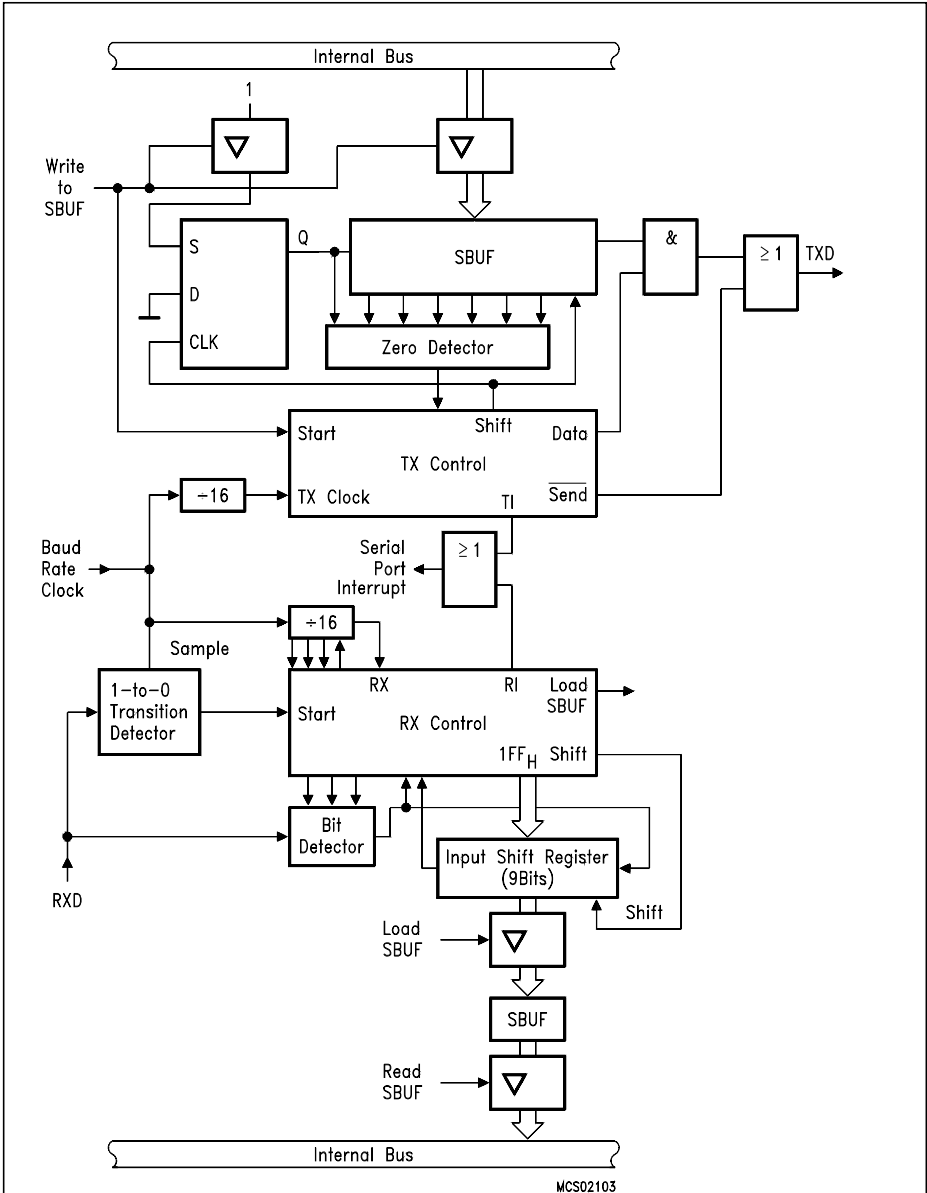

Figure 6-16a
Serial Interface, Mode 1, Functional Diagram

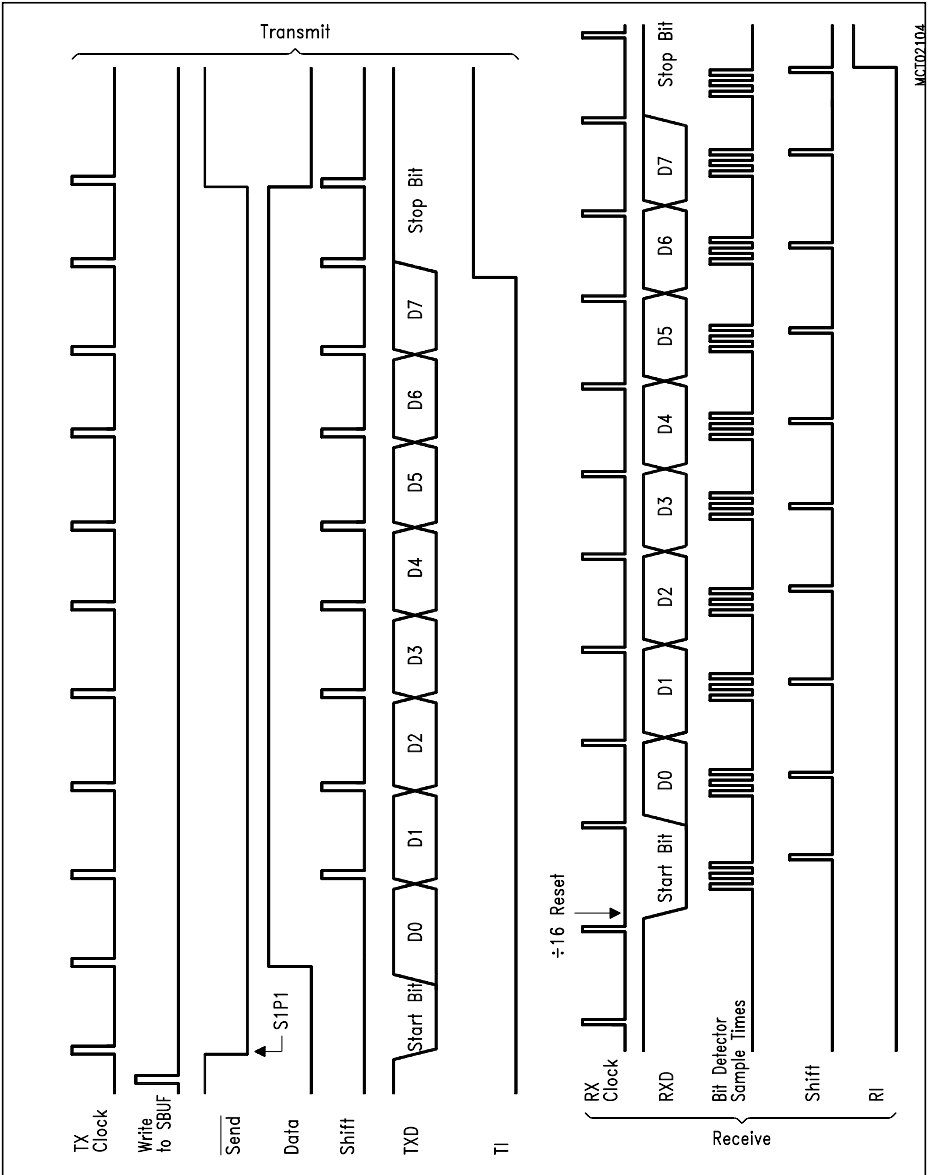

Figure 6-16b
Serial Interface, Mode 1, Timing Diagram

6.3.5 Details about Modes 2 and 3

Eleven bits are transmitted (through TXD), or received (through RXD): a start bit (0), 8 data bits (LSB first), a programmable 9th data bit, and a stop bit (1). On transmit, the 9th data bit (TB8) can be assigned the value of 0 or 1. On receive, the 9th data bit goes into RB8 in SCON. The baud rate is programmable to either 1/32 or 1/64 the oscillator frequency in mode 2 (When bit SMOD in SFR PCON (87_H) is set, the baud rate is $f_{osc}/32$). Mode 3 may have a variable baud rate generated from either timer 1 or 2 depending on the state of TCLK and RCLK (SFR T2CON).

Figure 6-17a shows a functional diagram of the serial port in modes 2 and 3. The receive portion is exactly the same as in mode 1. The transmit portion differs from mode 1 only in the 9th bit of the transmit shift register. The associated timings for transmit/receive are illustrated in **figure 6-17b**.

Transmission is initiated by any instruction that uses SBUF as a destination register. The "WRITE to SBUF" signal also loads TB8 into the 9th bit position of the transmit shift register and flags the TX control unit that a transmission is requested. Transmission starts at the next rollover in the divide-by-16 counter. (Thus, the bit times are synchronized to the divide-by-16 counter, not to the "WRITE to SBUF" signal.)

The transmission begins with activation of SEND, which puts the start bit at TXD. One bit time later, DATA is activated, which enables the output bit of the transmit shift register to TXD. The first shift pulse occurs one bit time after that. The first shift clocks a 1 (the stop bit) into the 9th bit position of the shift register. Thereafter, only zeroes are clocked in. Thus, as data bits shift out to the right, zeroes are clocked in from the left. When TB8 is at the output position of the shift register, then the stop bit is just to the left of TB8, and all positions to the left of that contain zeroes. This condition flags the TX control unit to do one last shift and then deactivate SEND and set TI. This occurs at the 11th divide-by-16 rollover after "WRITE to SBUF".

Reception is initiated by a detected 1-to-0 transition at RXD. For this purpose RXD is sampled at a rate of 16 times whatever baud rate has been established. When a transition is detected, the divide-by-16 counter is immediately reset, and 1FF_H is written to the input shift register.

At the 7th, 8th and 9th counter states of each bit time, the bit detector samples the value of RXD. The value accepted is the value that was seen in at least 2 of the 3 samples. If the value accepted during the first bit time is not 0, the receive circuits are reset and the unit goes back to looking for another 1-to-0 transition. If the start bit proves valid, it is shifted into the input shift register, and reception of the rest of the frame will proceed.

As data bits come from the right, 1s shift out to the left. When the start bit arrives at the leftmost position in the shift register (which in modes 2 and 3 is a 9-bit register), it flags the RX control block to do one last shift, load SBUF and RB8, and to set RI. The signal to load SBUF and RB8, and to set RI, will be generated if, and only if, the following conditions are met at the time the final shift pulse is generated:

- 1) RI = 0, and
- 2) Either SM2 = 0 or the received 9th data bit = 1

If either of these conditions is not met, the received frame is irretrievably lost, and RI is not set. If both conditions are met, the received 9th data bit goes into RB8, and the first 8 data bits go into SBUF. One bit time later, whether the above conditions were met or not, the unit goes back to looking for a 1-to-0 transition at the RXD input.

Note that the value of the received stop bit is irrelevant to SBUF, RB8 or RI.

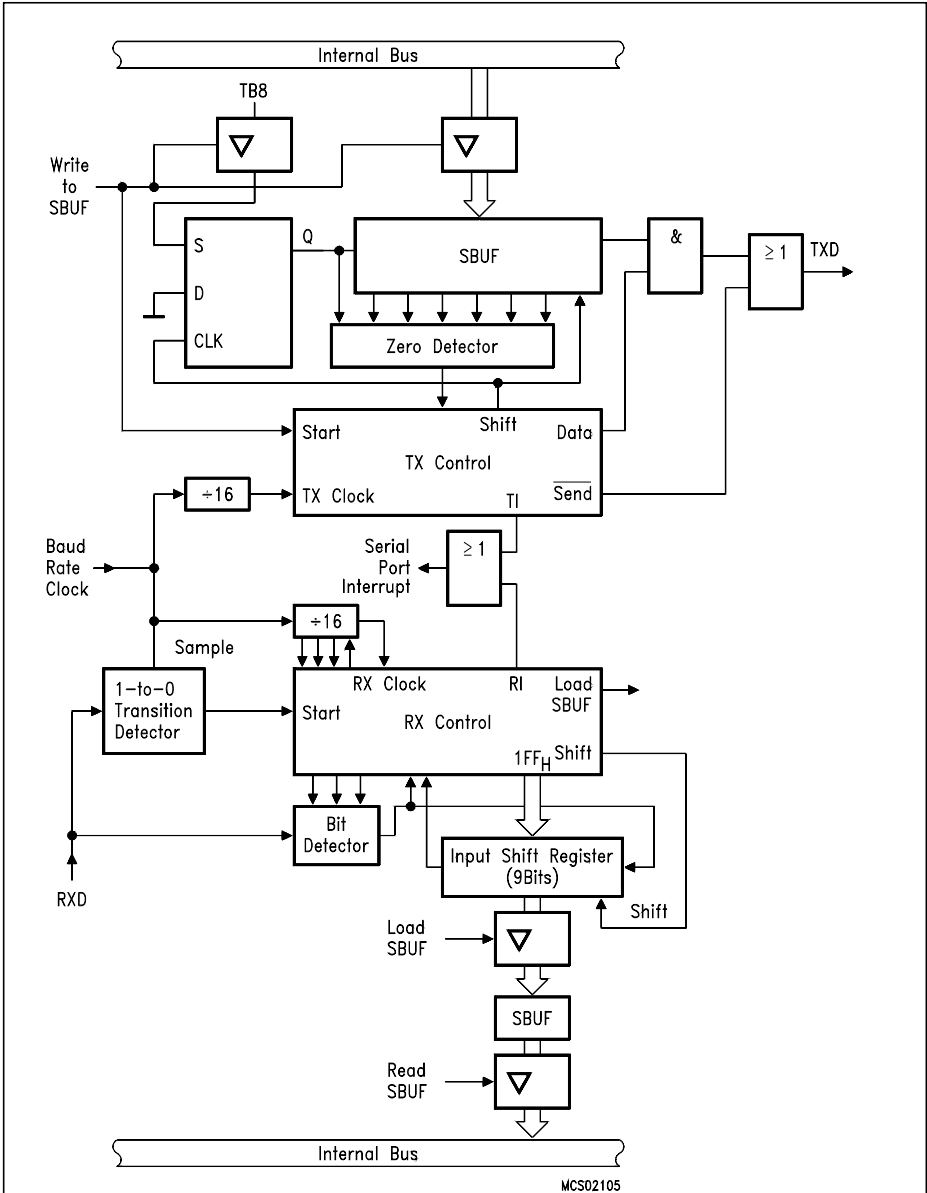

Figure 6-17a
Serial Interface, Mode 2 and 3, Functional Diagram

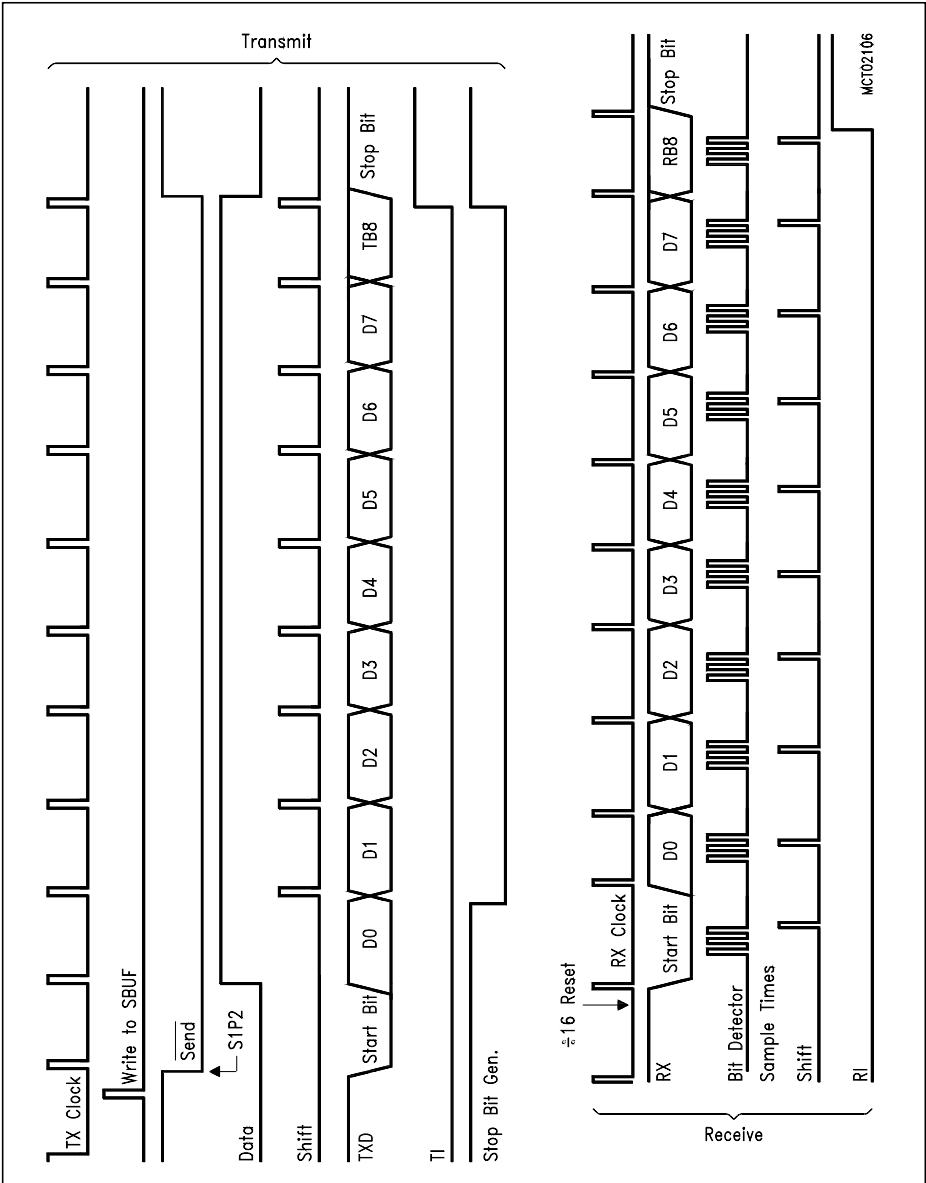

Figure 6-17b
Serial Interface, Mode 2 and 3, Timing Diagram

7 Interrupt System

The SAB-C501 provides 6 interrupt sources with two priority levels. Three interrupts can be generated by the on-chip peripherals (timer 0, timer 1, timer 2 and serial interface), and three interrupts may be triggered externally (P1.1/T2EX, P3.2/ $\overline{\text{INT0}}$ and P3.3/ $\overline{\text{INT1}}$).

Short Description of the Interrupt Structure for Advanced SAB-C501 Users

The interrupt structure of the SAB-C501 has been mainly adapted from the SAB 80C52. Thus, each interrupt source has its dedicated interrupt vector and can be enabled/disabled individually; there are also two priority levels available.

Figure 7-1 gives a general overview of the interrupt sources and illustrates the request and control flags described in the next sections.

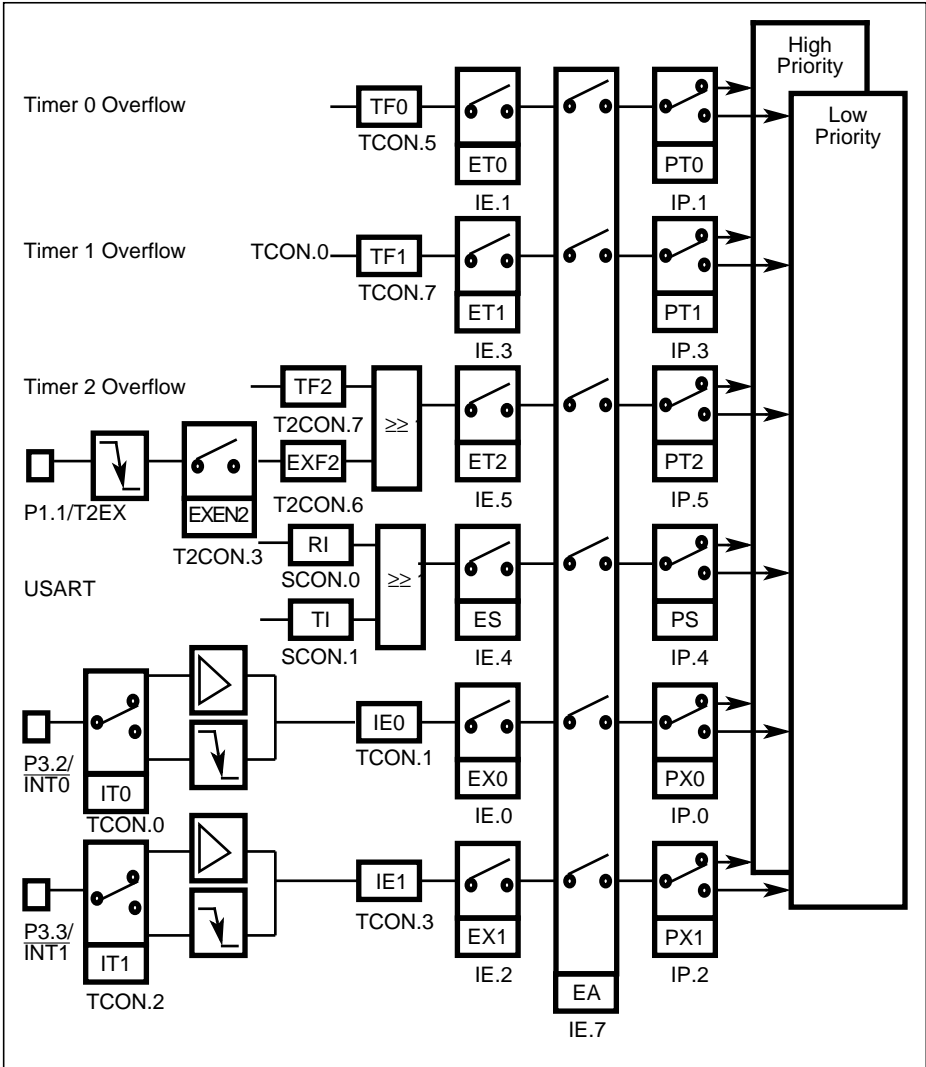

Figure 7-1
Interrupt Request Sources

7.1 Interrupt Structure

A common mechanism is used to generate the various interrupts, each source having its own request flag(s) located in a special function register (e.g. TCON, T2CON, SCON). Provided the peripheral or external source meets the condition for an interrupt, the dedicated request flag is set, whether an interrupt is enabled or not. For example, each timer 0 overflow sets the corresponding request flag TF0. If it is already set, it retains a one (1). But the interrupt is not necessarily serviced.

Now each interrupt requested by the corresponding flag can individually be enabled or disabled by the enable bits in SFR IE. This determines whether the interrupt will actually be performed. In addition, there is a global enable bit for all interrupts which, when cleared, disables all interrupts independent of their individual enable bits.

7.2 Interrupt Sources and Vectors

Source (Request Flags)	Vector	Vector Address
IE0	External interrupt 0	0003 _H
TF0	Timer 0 interrupt	000B _H
IE1	External interrupt 1	0013 _H
TF1	Timer 1 interrupt	001B _H
RI + TI	Serial port interrupt	0023 _H
TF2 + EXF2	Timer 2 interrupt	002B _H

7.3 Interrupt Control Bits

7.3.1 Interrupt Enables

Each interrupt vector can be individually enabled or disabled by setting or clearing the corresponding bit in the SFR IE (Interrupt Enable). This register also contains a globale disable bit (EA), which can be cleared to disable all interrupts at once.

Special Function Registers IE (Address A8_H)

Bit No.	MSB								LSB
	7	6	5	4	3	2	1	0	
Addr. A8 _H	EA	-	ET2	ES	ET1	EX1	ET0	EX0	IE

Bit	Function
-	Not implemented. Reserved for future use.
EA	Disables all Interrupts. If EA=0, no interrupt will be acknowledged. If EA=1, each interrupt source is individually enabled or disabled by setting or clearing its enable bit.
ET2	Timer 2 Interrupt Enable. If ET2 = 0, the Timer 2 interrupt is disabled.
ES	Serial Channel Interrupt Enable. If ES = 0, the Serial Channel interrupt is disabled.
ET1	Timer 1 Overflow Interrupt Enable. If ET1 = 0, the Timer 1 interrupt is disabled.
EX1	External Interrupt 1 Enable. If EX1 = 0, the external interrupt 1 is disabled.
ET0	Timer 0 Overflow Interrupt Enable. If ET0 = 0, the Timer 0 interrupt is disabled.
EX0	External Interrupt 0 Enable. If EX0 = 0, the external interrupt 0 is disabled.

Reset value of IE is 0X00 0000_B.

7.3.2 Interrupt Priorities

Each interrupt source can also be individually programmed to one of two priority levels by setting or clearing a bit in the SFR IP (Interrupt Priority, 0: low priority, 1: high priority).

Special Function Registers IP (Address B8_H)

Bit No.	MSB							LSB	
	7	6	5	4	3	2	1	0	
Addr. B8 _H	-	-	PT2	PS	PT1	PX1	PT0	PX0	IP

Bit	Function
-	Not implemented. Reserved for future use.
PT2	Timer 2 Interrupt Priority Level. If PT2 = 0, the Timer 2 interrupt has a low priority.
PS	Serial Channel Interrupt Priority Level. If PS = 0, the Serial Channel interrupt has a low priority.
PT1	Timer 1 Overflow Interrupt Priority Level. If PT1 = 0, the Timer 1 interrupt has a low priority.
PX1	External Interrupt 1 Priority Level. If PX1 = 0, the external interrupt 1 has a low priority.
PT0	Timer 0 Overflow Interrupt Priority Level. If PT0 = 0, the Timer 0 interrupt has a low priority.
PX0	External Interrupt 0 Priority Level. If PX0 = 0, the external interrupt 0 has a low priority.

Reset value of IP is XX00 0000_B.

A low-priority interrupt can itself be interrupted by a high-priority interrupt, but not by another low-priority interrupt. A high-priority interrupt cannot be interrupted by any other interrupt source.

If two requests of different priority level are received simultaneously, the request of higher priority is serviced. If requests of the same priority are received simultaneously, an internal polling sequence determines which request is serviced. Thus within each priority level there is a second priority structure determined by the polling sequence as shown in **table 7-1** below:

Table 7-1
Priority-within-Level Structure

Interrupt Source		Priority
External Interrupt 0,	IE0	High ↓ Low
Timer 0 Interrupt,	TF0	
External Interrupt 1,	IE1	
Timer 1 Interrupt,	TF1	
Serial Channel,	RI or TI	
Timer 2 Interrupt,	TF2 or EXF2	

The Interrupt request flags are located in bit-addressable SFR's as listed in **table 7-2**:

Table 7-2
Location of Interrupt Sources Request Flags

Interrupt Request Flag		SFR	Address	Bit-Addr.
External Interrupt 0,	IE0	TCON	88 _H	88 _H
Timer 0 Interrupt,	TF0	TCON	88 _H	8D _H
External Interrupt 1,	IE1	TCON	88 _H	8B _H
Timer 1 Interrupt,	TF1	TCON	88 _H	8F _H
Serial Channel,	RI	SCON	98 _H	98 _H
Serial Channel,	TI	SCON	98 _H	99 _H
Timer 2 Interrupt,	TF2	T2CON	C8 _H	CF _H
Timer 2 Interrupt,	EXF2	T2CON	C8 _H	CE _H

7.4 How Interrupts are Handled

The interrupt flags are sampled at S5P2 in each machine cycle. The sampled flags are polled during the following machine cycle. If one of the flags was in a set condition at S5P2 of the preceding cycle, the polling cycle will find it and the interrupt system will generate a LCALL to the appropriate service routine, provided this hardware-generated LCALL is not blocked by any of the following conditions:

- 1) An interrupt of equal or higher priority is already in progress.
- 2) The current (polling) cycle is not in the final cycle of the instruction in progress.
- 3) The instruction in progress is RETI or any write access to registers IE or IP.

Any of these three conditions will block the generation of the LCALL to the interrupt service routine. Condition 2 ensures that the instruction in progress is completed before vectoring to any service routine. Condition 3 ensures that if the instruction in progress is RETI or any write access to registers IE or IP, then at least one more instruction will be executed before any interrupt is vectored too; this delay guarantees that changes of the interrupt status can be observed by the CPU.

The polling cycle is repeated with each machine cycle, and the values polled are the values that were present at S5P2 of the previous machine cycle. Note that if any interrupt flag is active but not being responded to for one of the conditions already mentioned, or if the flag is no longer active when the blocking condition is removed, the denied interrupt will not be serviced. In other words, the fact that the interrupt flag was once active but not serviced is not remembered. Every polling cycle interrogates only the pending interrupt requests.

The polling cycle/LCALL sequence is illustrated in **figure 7-2**.

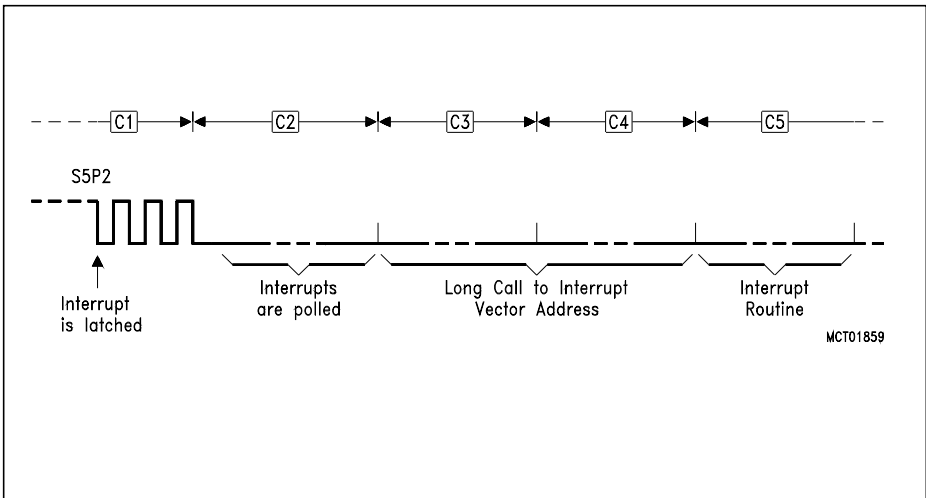

Figure 7-2
Interrupt Response Timing Diagram

Note that if an interrupt of a higher priority level goes active prior to S5P2 in the machine cycle labeled C3 in **figure 7-2** then, in accordance with the above rules, it will be vectored to during C5 and C6 without any instruction for the lower priority routine to be executed.

Thus, the processor acknowledges an interrupt request by executing a hardware-generated LCALL to the appropriate servicing routine. In some cases it also clears the flag that generated the interrupt, while in other cases it does not; then this has to be done by the user's software. The hardware clears the external interrupt flags IE0 and IE1 only if they were transition-activated. The hardware-generated LCALL pushes the contents of the program counter onto the stack (but it does not save the PSW) and reloads the program counter with an address that depends on the source of the interrupt being vectored too.

Execution proceeds from that location until the RETI instruction is encountered. The RETI instruction informs the processor that the interrupt routine is no longer in progress, then pops the two top bytes from the stack and reloads the program counter. Execution of the interrupted program continues from the point where it was stopped. Note that the RETI instruction is very important because it informs the processor that the program left the current interrupt priority level. A simple RET instruction would also have returned execution to the interrupted program, but it would have left the interrupt control system thinking an interrupt was still in progress. In this case no interrupt of the same or lower priority level would be acknowledged.

7.5 External Interrupts

The external interrupts 0 and 1 can be programmed to be level-activated or negative-transition activated by setting or clearing bit IT0 or IT1, respectively, in register TCON. If $IT_x = 0$ ($x = 0$ or 1), external interrupt x is triggered by a detected low level at the \overline{INT}_x pin. If $IT_x = 1$, external interrupt x is negative edge-triggered. In this mode, if successive samples of the \overline{INT}_x pin show a high in one cycle and a low in the next cycle, interrupt request flag IE_x in TCON is set. Flag bit IE_x then requests the interrupt.

If the external interrupt 0 or 1 is level-activated, the external source has to hold the request active until the requested interrupt is actually generated. Then it has to deactivate the request before the interrupt service routine is completed, or else another interrupt will be generated.

The external timer 2 reload trigger interrupt request flag EXF2 will be activated by a negative transition at pin P1.1/T2EX but only if bit EXEN2 is set.

Since the external interrupt pins are sampled once in each machine cycle, an input low should be held for at least 12 oscillator periods to ensure sampling. If the external interrupt is transition-activated, the external source has to hold the request pin high for at least one cycle, and then hold it low for at least one cycle to ensure that the transition is recognized so that the corresponding interrupt request flag will be set (**see figure 7-3**). The external interrupt request flags will automatically be cleared by the CPU when the service routine is called.

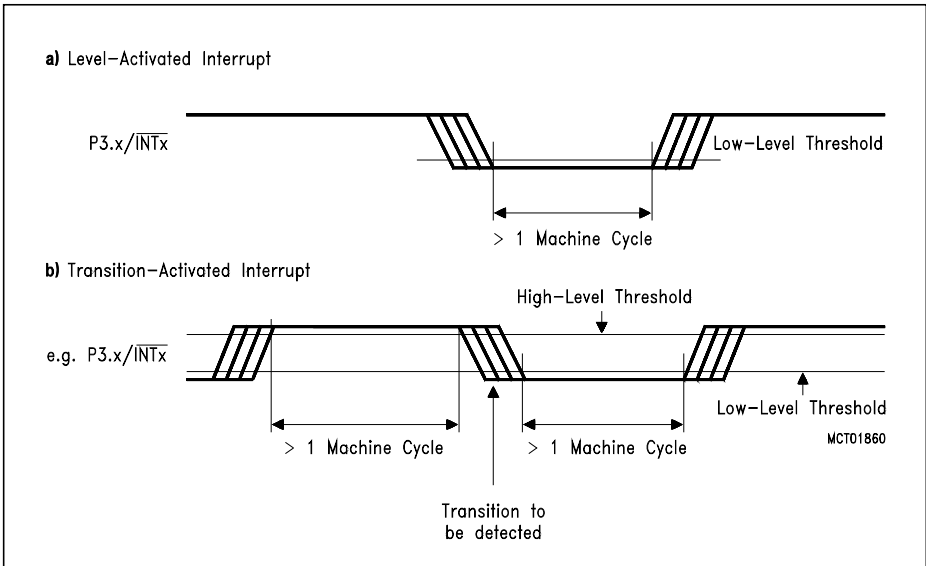

Figure 7-3
External Interrupt Detection

7.6 Response Time

If an external interrupt is recognized, its corresponding request flag is set at S5P2 in every machine cycle. The value is not polled by the circuitry until the next machine cycle. If the request is active and conditions are right for it to be acknowledged, a hardware subroutine call to the requested service routine will be next instruction to be executed. The call itself takes two cycles. Thus a minimum of three complete machine cycles will elapse between activation and external interrupt request and the beginning of execution of the first instruction of the service routine.

A longer response time would be obtained if the request was blocked by one of the three previously listed conditions. If an interrupt of equal or higher priority is already in progress, the additional wait time obviously depends on the nature of the other interrupt's service routine. If the instruction in progress is not in its final cycle, the additional wait time cannot be more than 3 cycles since the longest instructions (MUL and DIV) are only 4 cycles long; and, if the instruction in progress is RETI or a write access to registers IE or IP the additional wait time cannot be more than 5 cycles (a maximum of one more cycle to complete the instruction in progress, plus 4 cycles to complete the next instruction, if the instruction is MUL or DIV).

Thus a single interrupt system, the response time is always more than 3 cycles and less than 9 cycles.

8 Power Saving Modes

The ACMOS technology of the SAB-C501 allows two power saving modes of the device:

- Idle mode
- Power-down mode.

The Special Function Register PCON

The bits PDE and IDLE, located in SFR PCON select the power-down mode or the idle mode, respectively.

If the power-down mode and the idle mode are set at the same time, power-down takes precedence.

Furthermore, register PCON contains two general purpose flags. For example, the flag bits GF0 and GF1 can be used to give an indication if an interrupt occurred during normal operation or during an idle. Then an instruction that activates idle can also set one or both flag bits. When idle is terminated by an interrupt, the interrupt service routine can examine the flag bits.

Special Function Register (Address 87_H)

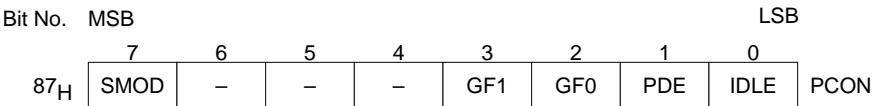

Symbol	Position	Function
SMOD	PCON.7	Baud rate doubled. When set, the baud rate of the serial channel in mode 1,2,3 is doubled.
-	PCON.4	Not implemented. Reserved for future use.
GF1	PCON.3	General purpose flag
GF0	PCON.2	General purpose flag
PDE	PCON.1	Power-down enable bit. When set, starting of the power-down is enabled
IDLE	PCON.0	Idle mode enable bit. When set, starting of the idle mode is enabled

The reset value of PCON is 0XXX 0000_B.

8.1 Idle Mode

In the idle mode the oscillator of the SAB-C501 continues to run, but the CPU is gated off from the clock signal. However, the interrupt system, the serial port, and all timers are further provided with the clock. The CPU status is preserved in its entirety: the stack pointer, program counter, program status word, accumulator, and all other registers maintain their data during idle mode.

The reduction of power consumption, which can be achieved by this feature depends on the number of peripherals running.

If all timers are stopped and the serial interface is not running, the maximum power reduction can be achieved. This state is also the test condition for the idle mode I_{CC} .

So the user has to take care which peripheral should continue to run and which has to be stopped during idle mode. Also the state of all port pins – either the pins controlled by their latches or controlled by their secondary functions – depends on the status of the controller when entering idle mode.

Normally the port pins hold the logical state they had at the time idle mode was activated. If some pins are programmed to serve their alternate functions they still continue to output during idle mode if the assigned function is on. This applies to the serial interface in case it cannot finish reception or transmission during normal operation. The control signals ALE and PSEN hold at logic high levels.

**Table 8-1
Status of External Pins During Idle and Power-Down Mode**

Outputs	Last Instruction Executed from Internal Code Memory		Last Instruction Executed from External Code Memory	
	Idle	Power-Down	Idle	Power-Down
ALE	High	Low	High	Low
PSEN	High	Low	High	Low
PORT 0	Data	Data	Data	Float
PORT 1	Data	Data	Data	Data
PORT 2	Data	Data	Address	Data
PORT 3	Data/alternate outputs	Data/last output	Data/alternate outputs	Data/last output

As in normal operation mode, the ports can be used as inputs during idle mode. Thus a capture or reload operation can be triggered, the timers can be used to count external events, and external interrupts will be detected.

The idle mode is a useful feature which makes it possible to "freeze" the processor's status - either for a predefined time, or until an external event reverts the controller to normal operation, as discussed below.

The idle mode is entered by setting the flag bit IDLE (PCON.0).

Note:

PCON is not a bit-addressable register, so the above mentioned sequence for entering the idle mode is obtained by a byte-handling instruction, as shown in the following example:

ORL PCON,#0000001B;Set bit IDLE

The instruction that sets bit IDLE is the last instruction executed before going into idle mode.

There are two ways to terminate the idle mode:

- The idle mode can be terminated by activating any enabled interrupt. This interrupt will be serviced and normally the instruction to be executed following the RETI instruction will be the one following the instruction that sets the bit IDLE.*
- The other way to terminate the idle mode, is a hardware reset. Since the oscillator is still running, the hardware reset must be held active only for two machine cycles for a complete reset.*

8.2 Power-Down Mode

In the power-down mode, the on-chip oscillator is stopped. Therefore all functions are stopped; only the contents of the on-chip RAM and the SFR's are maintained. The port pins controlled by their port latches output the values that are held by their SFR's. The port pins which serve the alternate output functions show the values they had at the end of the last cycle of the instruction which initiated the power-down mode. ALE and $\overline{\text{PSEN}}$ hold at logic low level (**see table 9-1**).

The power-down mode is entered by setting the flag bit PDE (PCON.1).

Note:

PCON is not a bit-addressable register, so the above mentioned sequence for entering the power-down mode is obtained by a byte-handling instruction, as shown in the following example:

```
ORL     PCON,#00000010B    ;Set bit PDE
```

The instruction that sets bit PDE is the last instruction executed before going into power-down mode.

The only exit from power-down mode is a hardware reset. Reset will redefine all SFR's, but will not change the contents of the internal RAM.

In the power-down mode of operation, V_{CC} can be reduced to minimize power consumption. It must be ensured, however, that V_{CC} is not reduced before the power-down mode is invoked, and that V_{CC} is restored to its normal operating level, before the power-down mode is terminated. The reset signal that terminates the power-down mode also restarts the oscillator. The reset should not be activated before V_{CC} is restored to its normal operating level and must be held active long enough to allow the oscillator to restart and stabilize (similar to power-on reset).

Absolute Maximum Ratings

Ambient temperature under bias (T_A)	- 40 to + 85 °C
Storage temperature (T_{ST})	- 65 to + 150 °C
Voltage on V_{CC} pins with respect to ground (V_{SS})	- 0.5 V to 6.5 V
Voltage on any pin with respect to ground (V_{SS})	- 0.5 V to $V_{CC} + 0.5$ V
Input current on any pin during overload condition	- 10 mA to + 10 mA
Absolute sum of all input currents during overload condition	100 mA
Power dissipation	TBD

Note: Stresses above those listed under "Absolute Maximum Ratings" may cause permanent damage of the device. This is a stress rating only and functional operation of the device at these or any other conditions above those indicated in the operational sections of this specification is not implied. Exposure to absolute maximum rating conditions for longer periods may affect device reliability. During overload conditions ($V_{IN} > V_{CC}$ or $V_{IN} < V_{SS}$) the Voltage on V_{CC} pins with respect to ground (V_{SS}) must not exceed the values defined by the absolute maximum ratings.

DC Characteristics

$V_{CC} = 5\text{ V} + 10\%, -15\%$; $V_{SS} = 0\text{ V}$;

$T_A = 0\text{ }^\circ\text{C}$ to $70\text{ }^\circ\text{C}$ for the SAB-C501

$T_A = -40\text{ }^\circ\text{C}$ to $85\text{ }^\circ\text{C}$ for the SAF-C501

Parameter	Symbol	Limit Values		Unit	Test Condition
		min.	max.		
Input low voltage (except \overline{EA} , RESET)	V_{IL}	-0.5	$0.2 V_{CC} - 0.1$	V	-
Input low voltage (\overline{EA})	V_{IL1}	-0.5	$0.2 V_{CC} - 0.3$	V	-
Input low voltage (RESET)	V_{IL2}	-0.5	$0.2 V_{CC} + 0.1$	V	-
Input high voltage (except XTAL1, \overline{EA} , RESET)	V_{IH}	$0.2 V_{CC} + 0.9$	$V_{CC} + 0.5$	V	-
Input high voltage to XTAL1	V_{IH1}	$0.7 V_{CC}$	$V_{CC} + 0.5$	V	
Input high voltage to \overline{EA} , RESET	V_{IH2}	$0.6 V_{CC}$	$V_{CC} + 0.5$	V	-
Output low voltage (ports 1, 2, 3)	V_{OL}	-	0.45	V	$I_{OL} = 1.6\text{ mA}^{1)}$
Output low voltage (port 0, ALE, \overline{PSEN})	V_{OL1}	-	0.45	V	$I_{OL} = 3.2\text{ mA}^{1)}$
Output high voltage (ports 1, 2, 3)	V_{OH}	2.4 $0.9 V_{CC}$	- -	V	$I_{OH} = -80\text{ }\mu\text{A}$, $I_{OH} = -10\text{ }\mu\text{A}$
Output high voltage (port 0 in external bus mode, ALE, \overline{PSEN})	V_{OH1}	2.4 $0.9 V_{CC}$	- -	V	$I_{OH} = -800\text{ }\mu\text{A}^{2)}$, $I_{OH} = -80\text{ }\mu\text{A}^{2)}$
Logic 0 input current (ports 1, 2, 3)	I_{IL}	-10	-50	μA	$V_{IN} = 0.45\text{ V}$
Logical 1-to-0 transition current (ports 1, 2, 3)	I_{TL}	-65	-650	μA	$V_{IN} = 2\text{ V}$
Input leakage current (port 0, \overline{EA})	I_{LI}	-	± 1	μA	$0.45 < V_{IN} < V_{CC}$
Pin capacitance	C_{IO}	-	10	pF	$f_C = 1\text{ MHz}$, $T_A = 25\text{ }^\circ\text{C}$
Power supply current:					
Active mode, 12 MHz ⁷⁾	I_{CC}	-	21	mA	$V_{CC} = 5\text{ V}$, ⁴⁾
Idle mode, 12 MHz ⁷⁾	I_{CC}	-	4.8	mA	$V_{CC} = 5\text{ V}$, ⁵⁾
Active mode, 20 MHz ⁷⁾	I_{CC}	-	31.1	mA	$V_{CC} = 5\text{ V}$, ⁴⁾
Idle mode, 20 MHz ⁷⁾	I_{CC}	-	7.0	mA	$V_{CC} = 5\text{ V}$, ⁵⁾
Active mode, 40 MHz ⁷⁾	I_{CC}	-	56.5	mA	$V_{CC} = 5\text{ V}$, ⁴⁾
Idle mode, 40 MHz ⁷⁾	I_{CC}	-	12.5	mA	$V_{CC} = 5\text{ V}$, ⁵⁾
Power Down Mode	I_{PD}	-	50	μA	$V_{CC} = 2 \dots 5.5\text{ V}^{3)}$

- 1) Capacitive loading on ports 0 and 2 may cause spurious noise pulses to be superimposed on the V_{OL} of ALE and port 3. The noise is due to external bus capacitance discharging into the port 0 and port 2 pins when these pins make 1-to-0 transitions during bus operation. In the worst case (capacitive loading > 100 pF), the noise pulse on ALE line may exceed 0.8 V. In such cases it may be desirable to qualify ALE with a schmitt-trigger, or use an address latch with a schmitt-trigger strobe input.
- 2) Capacitive loading on ports 0 and 2 may cause the V_{OH} on ALE and \overline{PSEN} to momentarily fall below the 0.9 V_{CC} specification when the address lines are stabilizing.
- 3) I_{PD} (Power Down Mode) is measured under following conditions:
 $\overline{EA} = \text{Port0} = V_{CC}$; $\text{RESET} = V_{SS}$; $\text{XTAL2} = \text{N.C.}$; $\text{XTAL1} = V_{SS}$; all other pins are disconnected.
- 4) I_{CC} (active mode) is measured with:
 XTAL1 driven with t_{CLCH} , $t_{CHCL} = 5 \text{ ns}$, $V_{IL} = V_{SS} + 0.5 \text{ V}$, $V_{IH} = V_{CC} - 0.5 \text{ V}$; $\text{XTAL2} = \text{N.C.}$;
 $\overline{EA} = \text{Port0} = \text{RESET} = V_{CC}$; all other pins are disconnected. I_{CC} would be slightly higher if a crystal oscillator is used (appr. 1 mA).
- 5) I_{CC} (Idle mode) is measured with all output pins disconnected and with all peripherals disabled;
 XTAL1 driven with t_{CLCH} , $t_{CHCL} = 5 \text{ ns}$, $V_{IL} = V_{SS} + 0.5 \text{ V}$, $V_{IH} = V_{CC} - 0.5 \text{ V}$; $\text{XTAL2} = \text{N.C.}$;
 $\text{RESET} = \overline{EA} = V_{SS}$; $\text{Port0} = V_{CC}$; all other pins are disconnected;
- 7) $I_{CC \text{ Max}}$ at other frequencies is given by:
 active mode: $I_{CC} = 1.27 \times f_{OSC} + 5.73$
 idle mode: $I_{CC} = 0.28 \times f_{OSC} + 1.45$
 where f_{OSC} is the oscillator frequency in MHz. I_{CC} values are given in mA and measured at $V_{CC} = 5 \text{ V}$.

AC Characteristics for SAB-C501-LN / C501-RN

$V_{CC} = 5\text{ V} + 10\%, -15\%$; $V_{SS} = 0\text{ V}$

$T_A = 0\text{ }^\circ\text{C}$ to $70\text{ }^\circ\text{C}$ for the SAB-C501

$T_A = -40\text{ }^\circ\text{C}$ to $85\text{ }^\circ\text{C}$ for the SAF-C501

(C_L for port 0, ALE and $\overline{\text{PSEN}}$ outputs = 100 pF; C_L for all other outputs = 80 pF)

Program Memory Characteristics

Parameter	Symbol	Limit Values				Unit
		12 MHz Clock		Variable Clock $1/t_{\text{CLCL}} = 3.5\text{ MHz to }12\text{ MHz}$		
		min.	max.	min.	max.	
ALE pulse width	t_{LHLL}	127	–	$2t_{\text{CLCL}} - 40$	–	ns
Address setup to ALE	t_{AVLL}	43	–	$t_{\text{CLCL}} - 40$	–	ns
Address hold after ALE	t_{LLAX}	30	–	$t_{\text{CLCL}} - 53$	–	ns
ALE low to valid instr in	t_{LLIV}	–	233	–	$4t_{\text{CLCL}} - 100$	ns
ALE to $\overline{\text{PSEN}}$	t_{LLPL}	58	–	$t_{\text{CLCL}} - 25$	–	ns
$\overline{\text{PSEN}}$ pulse width	t_{PLPH}	215	–	$3t_{\text{CLCL}} - 35$	–	ns
$\overline{\text{PSEN}}$ to valid instr in	t_{PLIV}	–	150	–	$3t_{\text{CLCL}} - 100$	ns
Input instruction hold after $\overline{\text{PSEN}}$	t_{PXIX}	0	–	0	–	ns
Input instruction float after $\overline{\text{PSEN}}$	$t_{\text{PXIZ}}^*)$	–	63	–	$t_{\text{CLCL}} - 20$	ns
Address valid after $\overline{\text{PSEN}}$	$t_{\text{PXAV}}^*)$	75	–	$t_{\text{CLCL}} - 8$	–	ns
Address to valid instr in	t_{AVIV}	–	302	–	$5t_{\text{CLCL}} - 115$	ns
Address float to $\overline{\text{PSEN}}$	t_{AZPL}	0	–	0	–	ns

*) Interfacing the SAB-C501 to devices with float times up to 75 ns is permissible. This limited bus contention will not cause any damage to port 0 Drivers.

AC Characteristics for SAB-C501-L / C501-1R

External Data Memory Characteristics

Parameter	Symbol	Limit Values				Unit
		12 MHz Clock		Variable Clock $1/t_{\text{CLCL}} = 3.5 \text{ MHz to } 12 \text{ MHz}$		
		min.	max.	min.	max.	
$\overline{\text{RD}}$ pulse width	t_{RLRH}	400	–	$6t_{\text{CLCL}} - 100$	–	ns
$\overline{\text{WR}}$ pulse width	t_{WLWH}	400	–	$6t_{\text{CLCL}} - 100$	–	ns
Address hold after ALE	t_{LLAX2}	30	–	$t_{\text{CLCL}} - 53$	–	ns
$\overline{\text{RD}}$ to valid data in	t_{RLDV}	–	252	–	$5t_{\text{CLCL}} - 165$	ns
Data hold after $\overline{\text{RD}}$	t_{RHDX}	0	–	0	–	ns
Data float after $\overline{\text{RD}}$	t_{RHDZ}	–	97	–	$2t_{\text{CLCL}} - 70$	ns
ALE to valid data in	t_{LLDV}	–	517	–	$8t_{\text{CLCL}} - 150$	ns
Address to valid data in	t_{AVDV}	–	585	–	$9t_{\text{CLCL}} - 165$	ns
ALE to $\overline{\text{WR}}$ or $\overline{\text{RD}}$	t_{LLWL}	200	300	$3t_{\text{CLCL}} - 50$	$3t_{\text{CLCL}} + 50$	ns
Address valid to $\overline{\text{WR}}$ or $\overline{\text{RD}}$	t_{AVWL}	203	–	$4t_{\text{CLCL}} - 130$	–	ns
$\overline{\text{WR}}$ or $\overline{\text{RD}}$ high to ALE high	t_{WHLH}	43	123	$t_{\text{CLCL}} - 40$	$t_{\text{CLCL}} + 40$	ns
Data valid to $\overline{\text{WR}}$ transition	t_{QVWX}	33	–	$t_{\text{CLCL}} - 50$	–	ns
Data setup before $\overline{\text{WR}}$	t_{QVWH}	433	–	$7t_{\text{CLCL}} - 150$	–	ns
Data hold after $\overline{\text{WR}}$	t_{WHQX}	33	–	$t_{\text{CLCL}} - 50$	–	ns
Address float after $\overline{\text{RD}}$	t_{RLAZ}	–	0	–	0	ns

External Clock Drive

Parameter	Symbol	Limit Values		Unit
		Variable Clock Freq. = 3.5 MHz to 12 MHz		
		min.	max.	
Oscillator period	t_{CLCL}	83.3	285.7	ns
High time	t_{CHCX}	20	$t_{CLCL} - t_{CLCX}$	ns
Low time	t_{CLCX}	20	$t_{CLCL} - t_{CHCX}$	ns
Rise time	t_{CLCH}	–	20	ns
Fall time	t_{CHCL}	–	20	ns

AC Characteristics for SAB-C501-L20 / C501-1R20

$V_{CC} = 5\text{ V} + 10\%, -15\%$; $V_{SS} = 0\text{ V}$

$T_A = 0\text{ }^\circ\text{C}$ to $70\text{ }^\circ\text{C}$ for the SAB-C501

$T_A = -40\text{ }^\circ\text{C}$ to $85\text{ }^\circ\text{C}$ for the SAF-C501

(C_L for port 0, ALE and $\overline{\text{PSEN}}$ outputs = 100 pF; C_L for all other outputs = 80 pF)

Program Memory Characteristics

Parameter	Symbol	Limit Values				Unit
		20 MHz Clock		Variable Clock $1/t_{\text{CLCL}} = 3.5\text{ MHz to }20\text{ MHz}$		
		min.	max.	min.	max.	
ALE pulse width	t_{LHLL}	60	–	$2t_{\text{CLCL}} - 40$	–	ns
Address setup to ALE	t_{AVLL}	20	–	$t_{\text{CLCL}} - 30$	–	ns
Address hold after ALE	t_{LLAX}	20	–	$t_{\text{CLCL}} - 30$	–	ns
ALE low to valid instr in	t_{LLIV}	–	100	–	$4t_{\text{CLCL}} - 100$	ns
ALE to $\overline{\text{PSEN}}$	t_{LLPL}	25	–	$t_{\text{CLCL}} - 25$	–	ns
$\overline{\text{PSEN}}$ pulse width	t_{PLPH}	115	–	$3t_{\text{CLCL}} - 35$	–	ns
$\overline{\text{PSEN}}$ to valid instr in	t_{PLIV}	–	75	–	$3t_{\text{CLCL}} - 75$	ns
Input instruction hold after $\overline{\text{PSEN}}$	t_{PXIX}	0	–	0	–	ns
Input instruction float after $\overline{\text{PSEN}}$	$t_{\text{PXIZ}}^*)$	–	40	–	$t_{\text{CLCL}} - 10$	ns
Address valid after $\overline{\text{PSEN}}$	$t_{\text{PXAV}}^*)$	47	–	$t_{\text{CLCL}} - 3$	–	ns
Address to valid instr in	t_{AVIV}	–	190	–	$5t_{\text{CLCL}} - 60$	ns
Address float to $\overline{\text{PSEN}}$	t_{AZPL}	0	–	0	–	ns

*) Interfacing the SAB-C501 to devices with float times up to 45 ns is permissible. This limited bus contention will not cause any damage to port 0 Drivers.

AC Characteristics for SAB-C501-L20 / C501-1R20

External Data Memory Characteristics

Parameter	Symbol	Limit Values				Unit
		20 MHz Clock		Variable Clock $1/t_{CLCL} = 3.5 \text{ MHz to } 20 \text{ MHz}$		
		min.	max.	min.	max.	
\overline{RD} pulse width	t_{RLRH}	200	–	$6t_{CLCL} - 100$	–	ns
\overline{WR} pulse width	t_{WLWH}	200	–	$6t_{CLCL} - 100$	–	ns
Address hold after ALE	t_{LLAX2}	20	–	$t_{CLCL} - 30$	–	ns
\overline{RD} to valid data in	t_{RLDV}	–	155	–	$5t_{CLCL} - 95$	ns
Data hold after \overline{RD}	t_{RHDX}	0	–	0	–	ns
Data float after \overline{RD}	t_{RHDZ}	–	76	–	$2t_{CLCL} - 24$	ns
ALE to valid data in	t_{LLDV}	–	250	–	$8t_{CLCL} - 150$	ns
Address to valid data in	t_{AVDV}	–	285	–	$9t_{CLCL} - 165$	ns
ALE to \overline{WR} or \overline{RD}	t_{LLWL}	100	200	$3t_{CLCL} - 50$	$3t_{CLCL} + 50$	ns
Address valid to \overline{WR} or \overline{RD}	t_{AVWL}	70	–	$4t_{CLCL} - 130$	–	ns
\overline{WR} or \overline{RD} high to ALE high	t_{WHLH}	20	80	$t_{CLCL} - 30$	$t_{CLCL} + 30$	ns
Data valid to \overline{WR} transition	t_{QVWX}	5	–	$t_{CLCL} - 45$	–	ns
Data setup before \overline{WR}	t_{QVWH}	200	–	$7t_{CLCL} - 150$	–	ns
Data hold after \overline{WR}	t_{WHQX}	10	–	$t_{CLCL} - 40$	–	ns
Address float after \overline{RD}	t_{RLAZ}	–	0	–	0	ns

External Clock Drive

Parameter	Symbol	Limit Values		Unit
		Variable Clock Freq. = 3.5 MHz to 20 MHz		
		min.	max.	
Oscillator period	t_{CLCL}	50	285.7	ns
High time	t_{CHCX}	12	$t_{CLCL} - t_{CLCX}$	ns
Low time	t_{CLCX}	12	$t_{CLCL} - t_{CHCX}$	ns
Rise time	t_{CLCH}	–	12	ns
Fall time	t_{CHCL}	–	12	ns

AC Characteristics for SAB-C501-L40 / C501-1R40

Advance Information

$V_{CC} = 5\text{ V} + 10\% , - 15\% ; V_{SS} = 0\text{ V}$

$T_A = 0\text{ }^\circ\text{C to } 70\text{ }^\circ\text{C}$ for the SAB-C501

$T_A = -40\text{ }^\circ\text{C to } 85\text{ }^\circ\text{C}$ for the SAF-C501

(C_L for port 0, ALE and $\overline{\text{PSEN}}$ outputs = 100 pF; C_L for all other outputs = 80 pF)

Program Memory Characteristics

Parameter	Symbol	Limit Values				Unit
		40 MHz Clock		Variable Clock $1/t_{CLCL} = 3.5\text{ MHz to } 40\text{ MHz}$		
		min.	max.	min.	max.	
ALE pulse width	t_{LHLL}	35	–	$2 t_{CLCL} - 15$	–	ns
Address setup to ALE	t_{AVLL}	10	–	$t_{CLCL} - 15$	–	ns
Address hold after ALE	t_{LLAX}	10	–	$t_{CLCL} - 15$	–	ns
ALE low to valid instr in	t_{LLIV}	–	55	–	$4 t_{CLCL} - 45$	ns
ALE to $\overline{\text{PSEN}}$	t_{LLPL}	10	–	$t_{CLCL} - 15$	–	ns
$\overline{\text{PSEN}}$ pulse width	t_{PLPH}	60	–	$3 t_{CLCL} - 15$	–	ns
$\overline{\text{PSEN}}$ to valid instr in	t_{PLIV}	–	25	–	$3 t_{CLCL} - 50$	ns
Input instruction hold after $\overline{\text{PSEN}}$	t_{PXIX}	0	–	0	–	ns
Input instruction float after $\overline{\text{PSEN}}$	$t_{PXIZ}^*)$	–	15	–	$t_{CLCL} - 10$	ns
Address valid after $\overline{\text{PSEN}}$	$t_{PXAV}^*)$	20	–	$t_{CLCL} - 5$	–	ns
Address to valid instr in	t_{AVIV}	–	65	–	$5 t_{CLCL} - 60$	ns
Address float to $\overline{\text{PSEN}}$	t_{AZPL}	– 5	–	– 5	–	ns

*) Interfacing the SAB-C501 to devices with float times up to 20ns is permissible. This limited bus contention will not cause any damage to port 0 Drivers.

AC Characteristics for SAB-C501-L40 / C501-1R40 (cont'd)

Advance Information

External Data Memory Characteristics

Parameter	Symbol	Limit Values				Unit
		40 MHz Clock		Variable Clock $1/t_{CLCL} = 3.5 \text{ MHz to } 40 \text{ MHz}$		
		min.	max.	min.	max.	
\overline{RD} pulse width	t_{RLRH}	120	–	$6 t_{CLCL} - 30$	–	ns
\overline{WR} pulse width	t_{WLVH}	120	–	$6 t_{CLCL} - 30$	–	ns
Address hold after ALE	t_{LLAX2}	10	–	$2 t_{CLCL} - 15$	–	ns
\overline{RD} to valid data in	t_{RLDV}	–	75	–	$5 t_{CLCL} - 50$	ns
Data hold after \overline{RD}	t_{RHDX}	0	–	0	–	ns
Data float after \overline{RD}	t_{RHDZ}	–	38	–	$2 t_{CLCL} - 12$	ns
ALE to valid data in	t_{LLDV}	–	150	–	$8 t_{CLCL} - 50$	ns
Address to valid data in	t_{AVDV}	–	150	–	$9 t_{CLCL} - 75$	ns
ALE to \overline{WR} or \overline{RD}	t_{LLWL}	60	90	$3 t_{CLCL} - 15$	$3 t_{CLCL} + 15$	ns
Address valid to \overline{WR} or \overline{RD}	t_{AVWL}	70	–	$4 t_{CLCL} - 30$	–	ns
\overline{WR} or \overline{RD} high to ALE high	t_{WHLH}	10	40	$t_{CLCL} - 15$	$t_{CLCL} + 15$	ns
Data valid to \overline{WR} transition	t_{QVWX}	5	–	$t_{CLCL} - 20$	–	ns
Data setup before \overline{WR}	t_{QVWH}	125	–	$7 t_{CLCL} - 50$	–	ns
Data hold after \overline{WR}	t_{WHQX}	5	–	$t_{CLCL} - 20$	–	ns
Address float after \overline{RD}	t_{RLAZ}	–	0	–	0	ns

Advance Information

External Clock Drive

Parameter	Symbol	Limit Values		Unit
		Variable Clock Freq. = 3.5 MHz to 40 MHz		
		min.	max.	
Oscillator period	t_{CLCL}	25	285.7	ns
High time	t_{CHCX}	10	$t_{CLCL} - t_{CLCX}$	ns
Low time	t_{CLCX}	10	$t_{CLCL} - t_{CHCX}$	ns
Rise time	t_{CLCH}	–	10	ns
Fall time	t_{CHCL}	–	10	ns

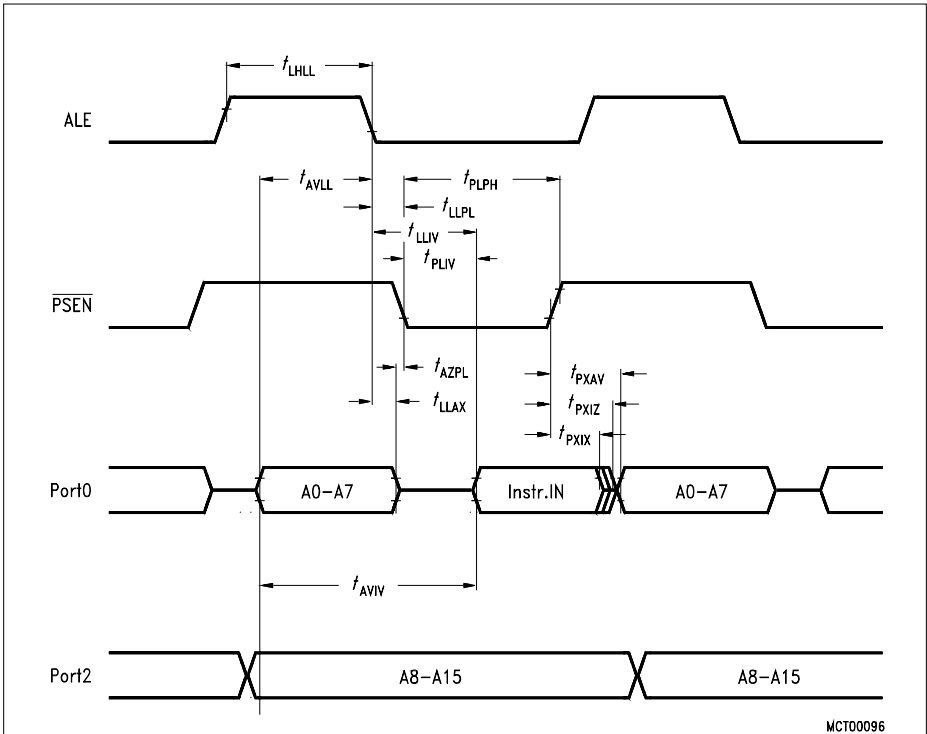

MCT00096

Figure 1
Program Memory Read Cycle

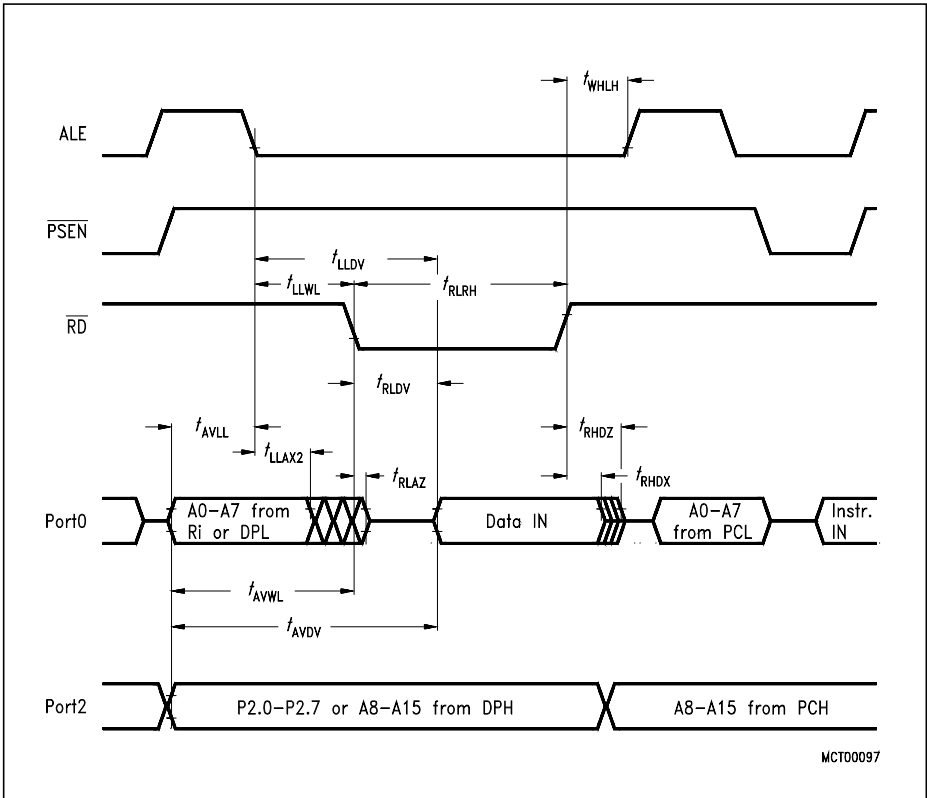

Figure 2
Data Memory Read Cycle

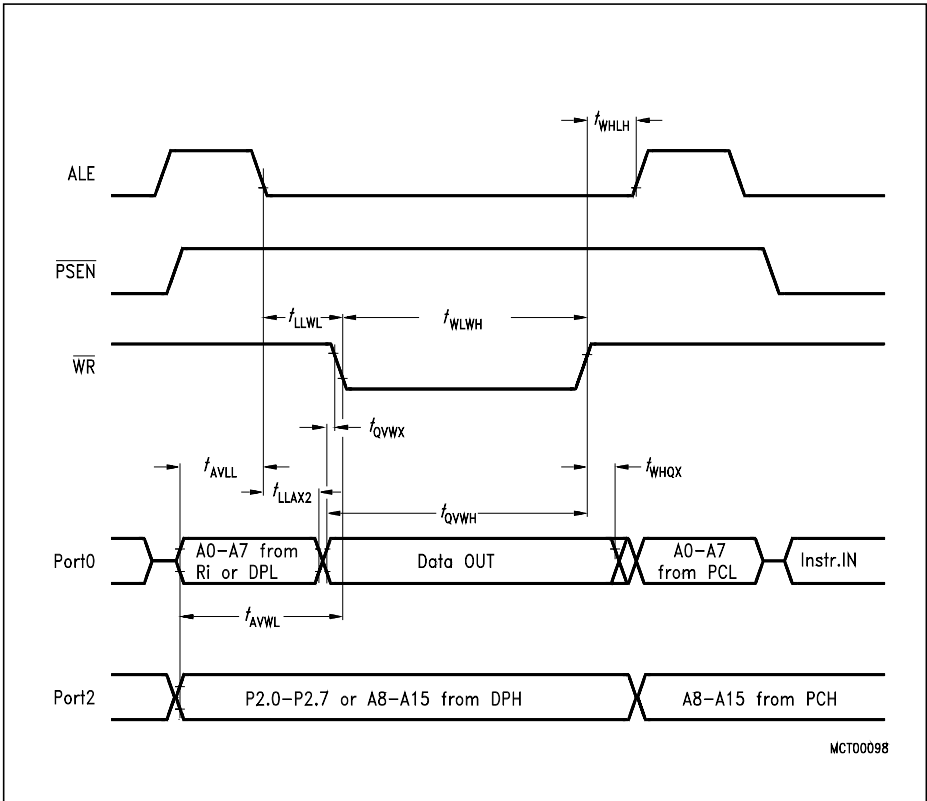

Figure 3
Data Memory Write Cycle

ROM Verification Characteristics for SAB-C501-1R

ROM Verification Mode 1

Parameter	Symbol	Limit Values		Unit
		min.	max.	
Address to valid data	t_{AVQV}	–	$48t_{CLCL}$	ns
ENABLE to valid data	t_{ELOV}	–	$48t_{CLCL}$	ns
Data float after ENABLE	t_{EHQZ}	0	$48t_{CLCL}$	ns
Oscillator frequency	$1/t_{CLCL}$	4	6	MHz

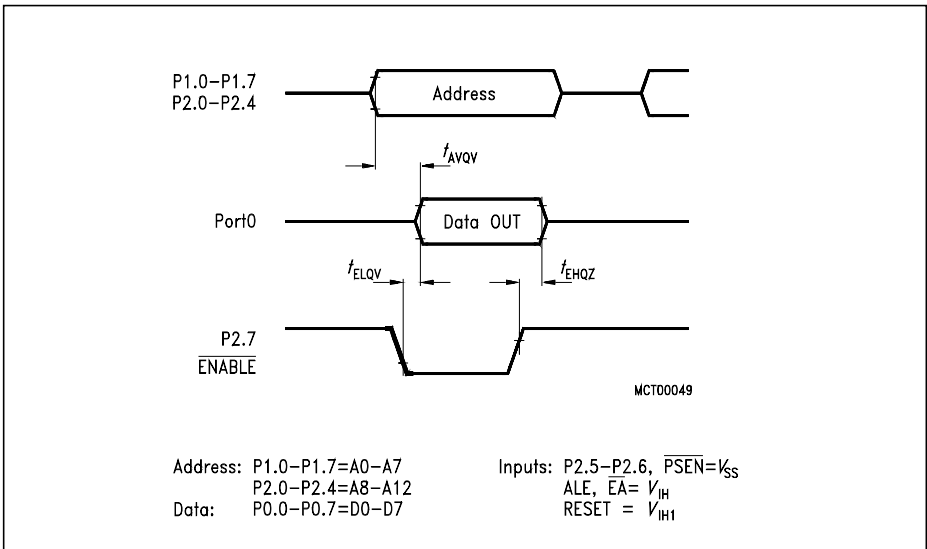

Figure 4
ROM Verification Mode 1

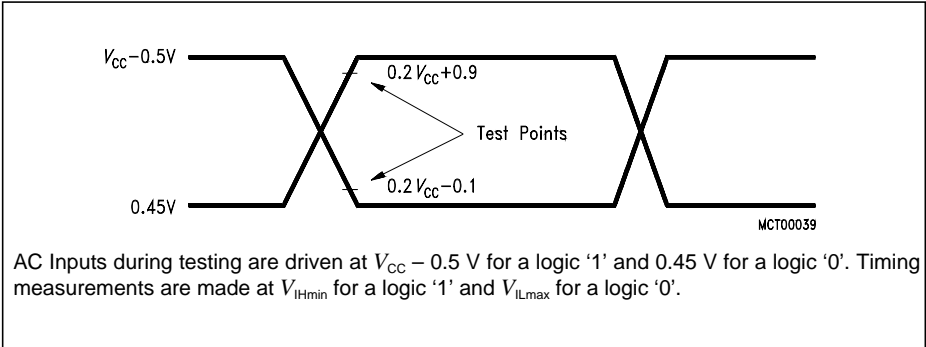

Figure 5
AC Testing: Input, Output Waveforms

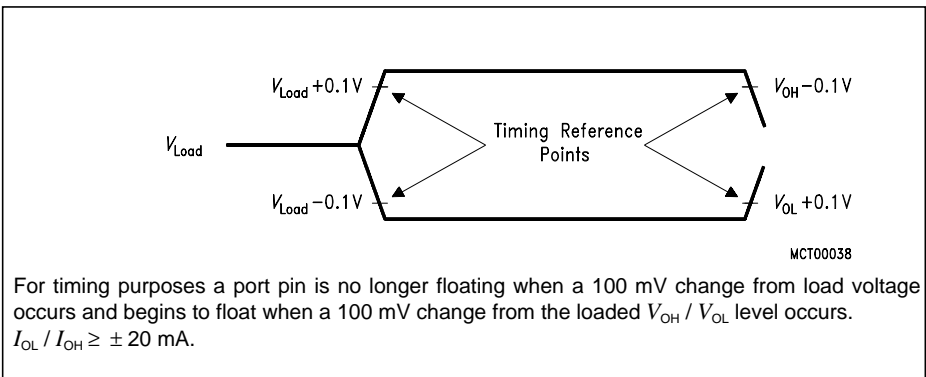

Figure 6
AC Testing: Float Waveforms

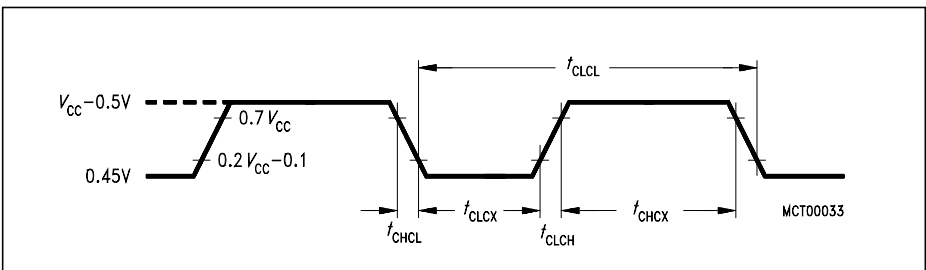

Figure 7
External Clock Cycle

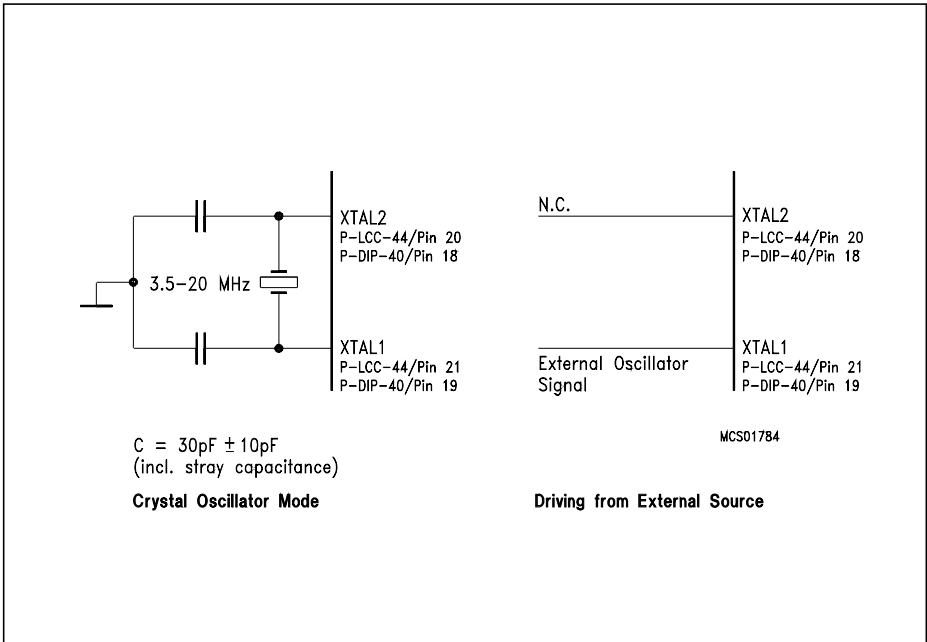
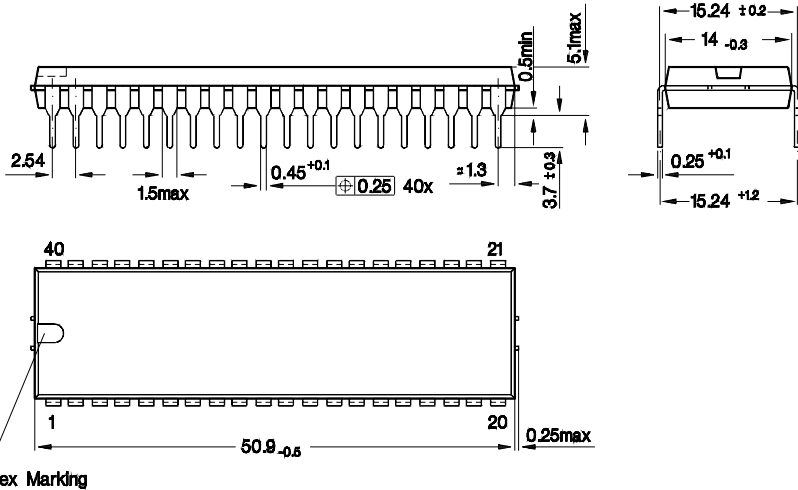

Figure 8
Recommended Oscillator Circuits

Plastic Package, P-DIP-40
(Plastic Dual in-Line Package)



Sorts of Packing

Package outlines for tubes, trays etc. are contained in our Data Book "Package Information"

SMD = Surface Mounted Device

Dimensions in mm

