

XC16Board Project

Sheet: 9 of 9
 Number:
 Revision: 2.0
 Date: 11-Jul-2001

Infineon Technologies AG
 AI MC AE
 St. Martin Strasse 76
 D-81541 Munich
 Tel.: +49-89-234-0



File: G:\Technical Support\Projects\XC16Board\EDA\XC16Board_V100\XC16Board.dtb - XC16Board V2.00\XC16Board.dtb

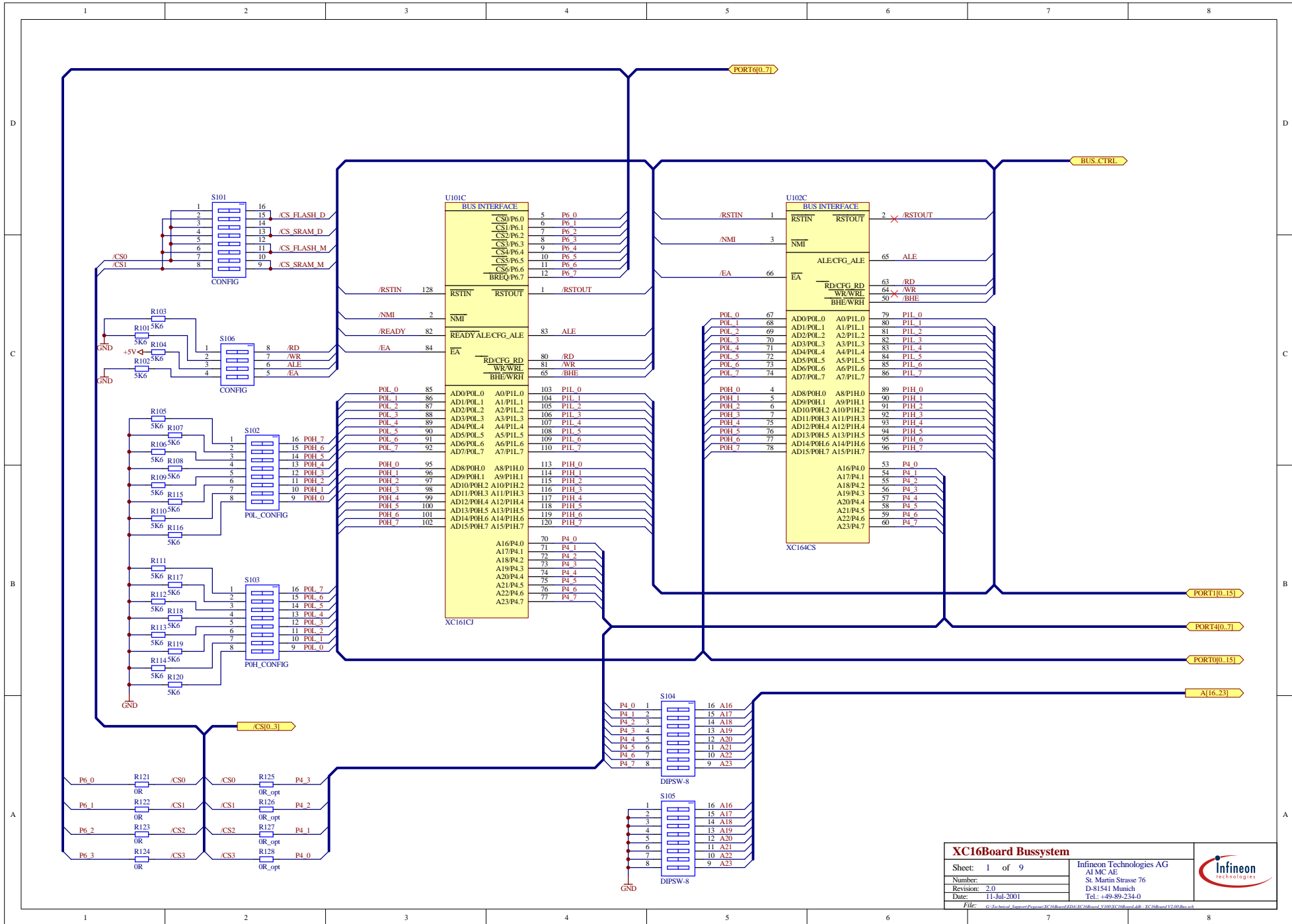

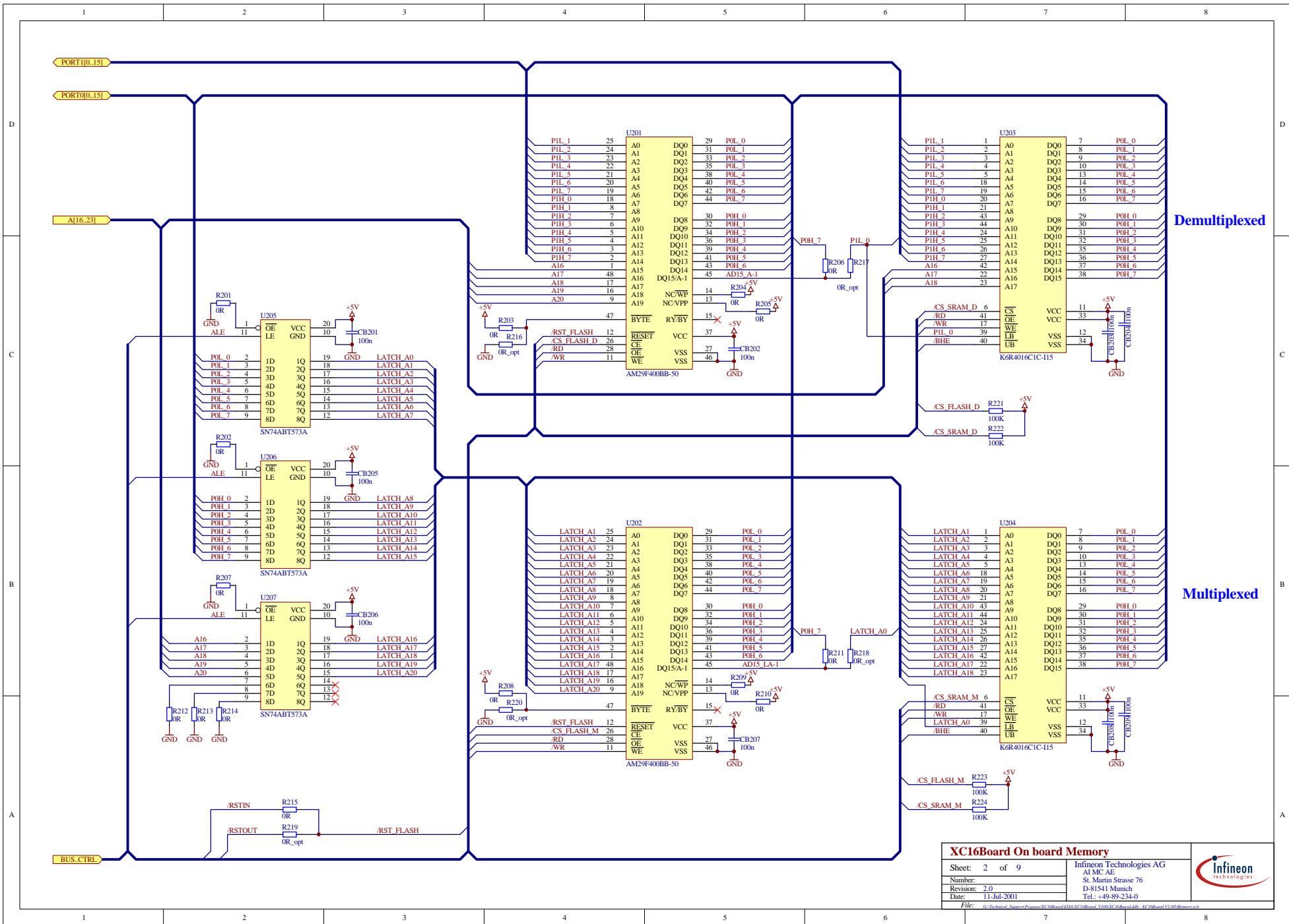

XC16Board On board Memory	
Sheet: 2 of 9	Infinion Technologies AG
Number: _____	AI MC AE
Revision: 2.0	St. Martin Strasse 76
Date: 11-Jul-2001	D-81541 Munich
	Tel.: +49-89-234-0



File: G:\Technical Support\Products\XC16Board\EDA\XC16Board_V100\XC16Board_06_XC16Board_V1.00_Memory.sch

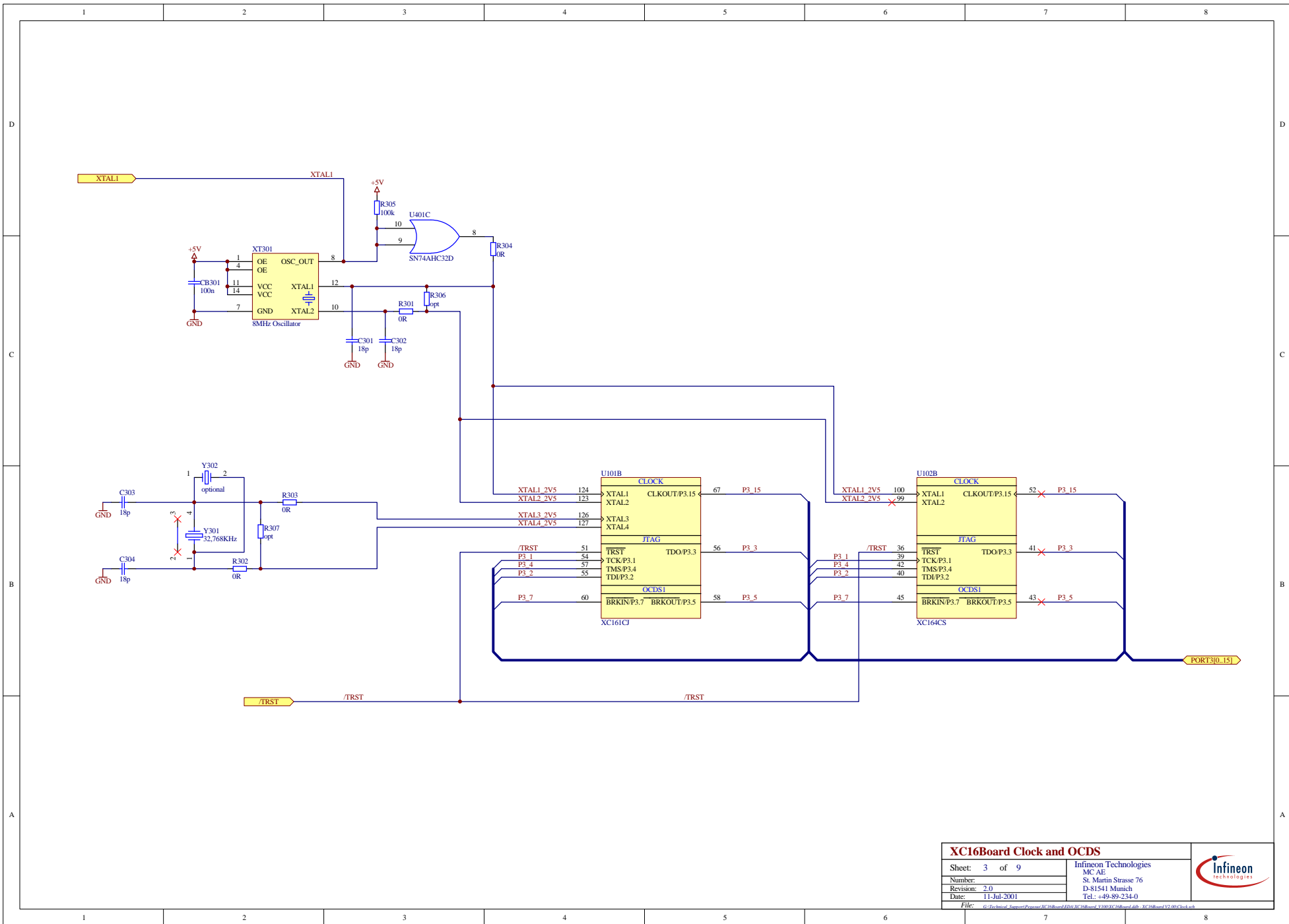

XC16Board Clock and OCDS		
Sheet: 3 of 9	Infineon Technologies	
Number: MC AE	St. Martin Strasse 76	
Revision: 2.0	D-81541 Munich	
Date: 11-Jul-2001	Tel.: +49-89-234-0	
<small>File: G:\Technical Support\Products\XC16Board\EDA\XC16Board_V100\XC16Board.ddb - XC16Board_V1.00\Clock.sch</small>		



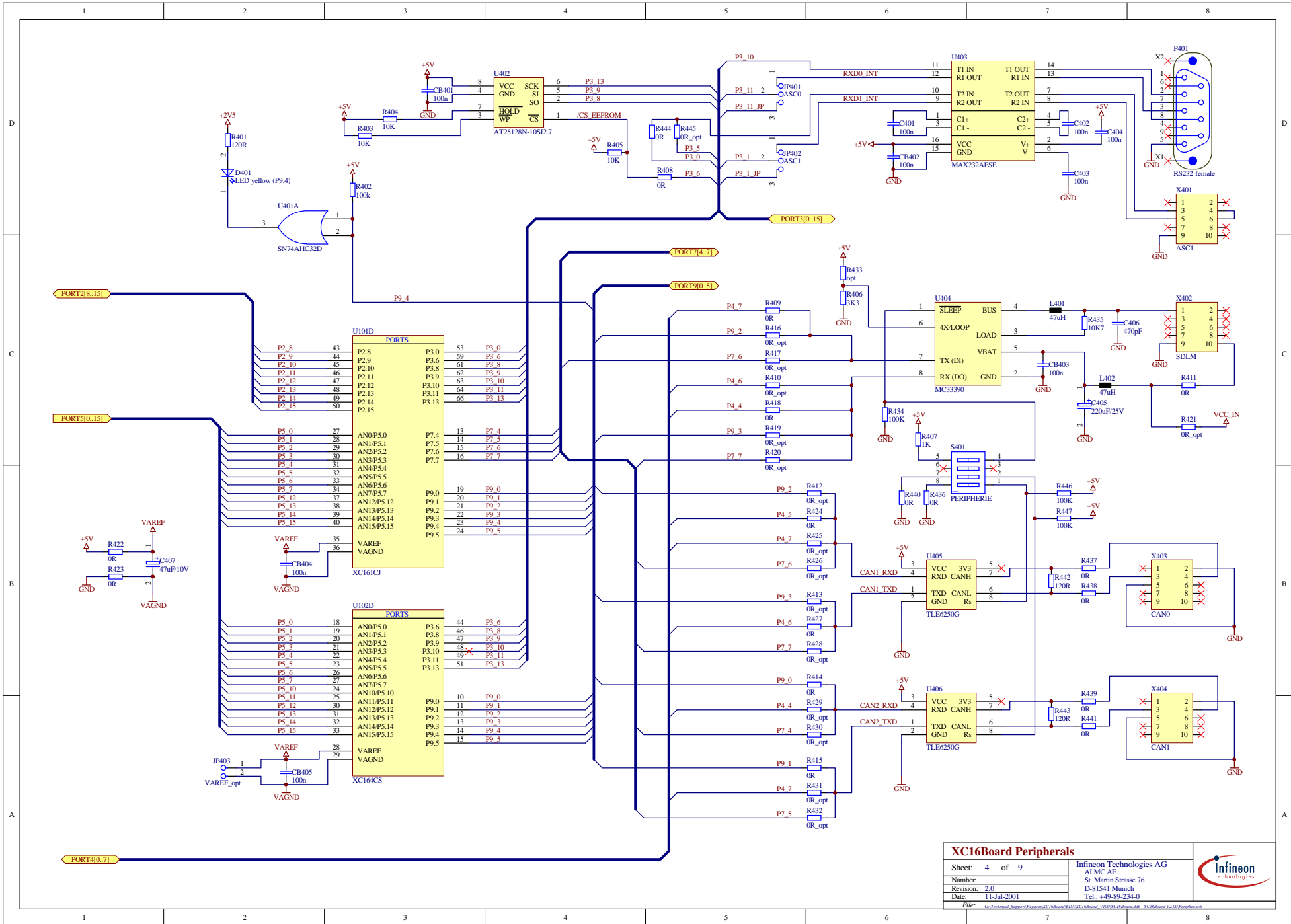

XC16Board Peripherals		Infineon Technologies AG
Sheet:	4 of 9	
Number:		St. Martin Strasse 76
Revision:	2.0	D-81541 Munich
Date:	11-Jul-2001	Tel.: +49-89-234-0
File: G:\Technical Support\Printer\XC16Board\EDA\XC16Board_V100\XC16Board.d06_XC16Board_V1.00_Peripherals		

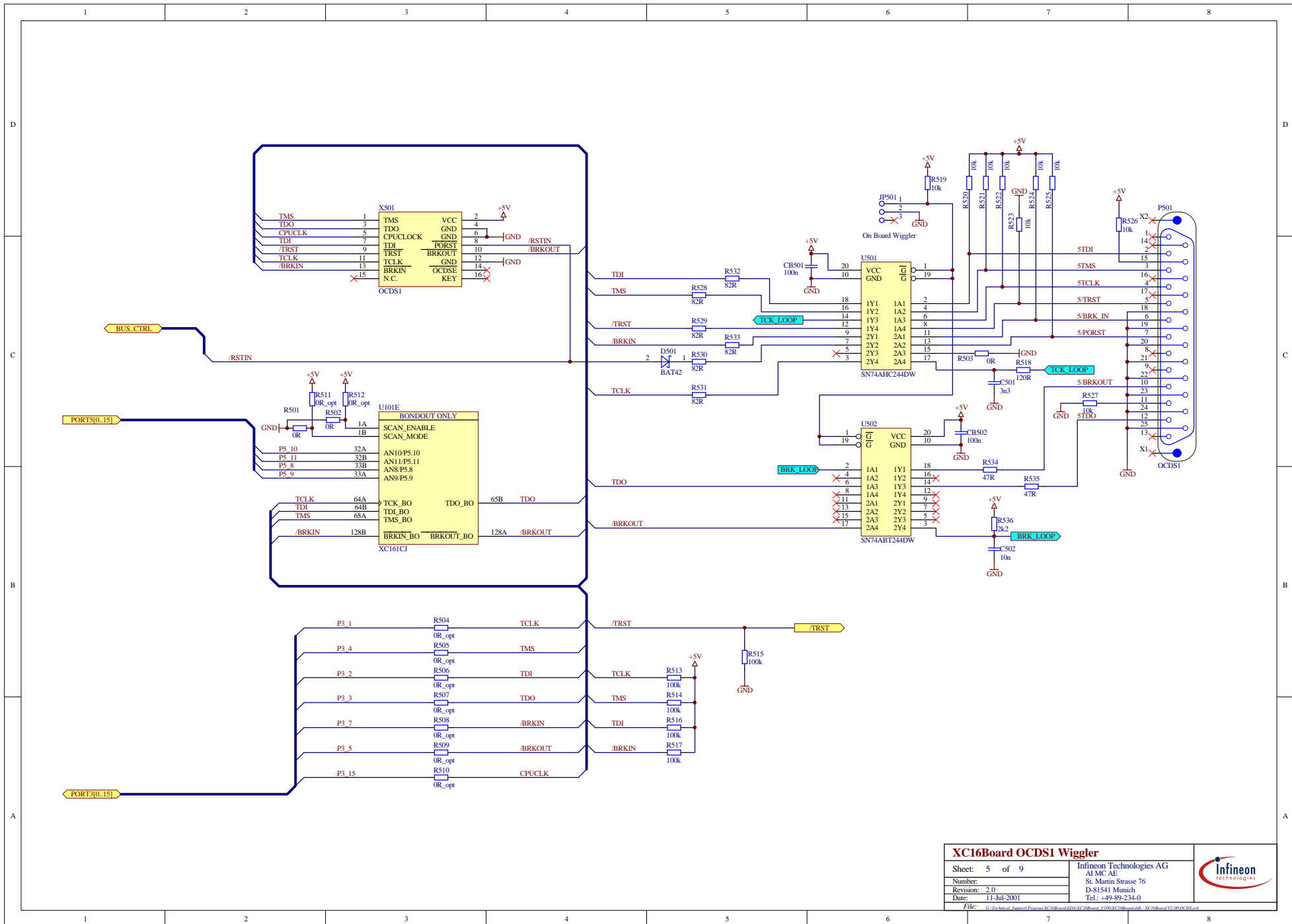

XC16Board OCDS1 Wiggler		
Sheet:	5 of 9	
Number:		AI MC AE
Revision:	2.0	St. Martin Strasse 76
Date:	11-Jul-2001	D-81541 Munich
		Tel.: +49-89-234-0

File: G:\Technical Support\Products\XC16Board\EDA\XC16Board_V100\XC16Board.ddb, XC16Board_V100\OCDS1.ddb

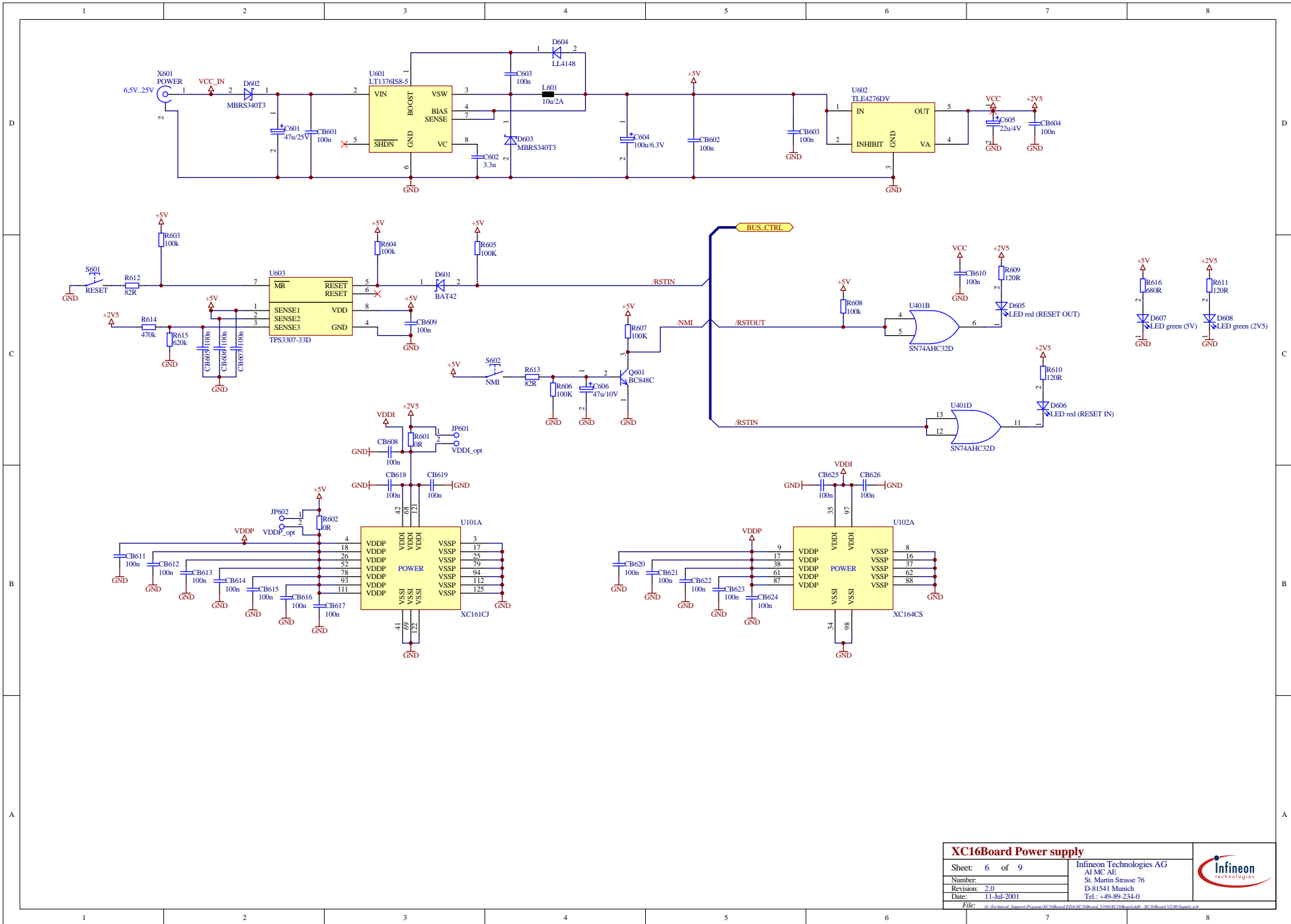

XC16Board Power supply		Infiniteon Technologies AG
Sheet:	6 of 9	
Number:		
Revision:	2.0	
Date:	11-Jul-2001	

File: G:\Technical Support\Power\XC16Board\EMAC\XC16Board_V100\XC16Board.dtb - XC16Board V2.00\Supply.sch

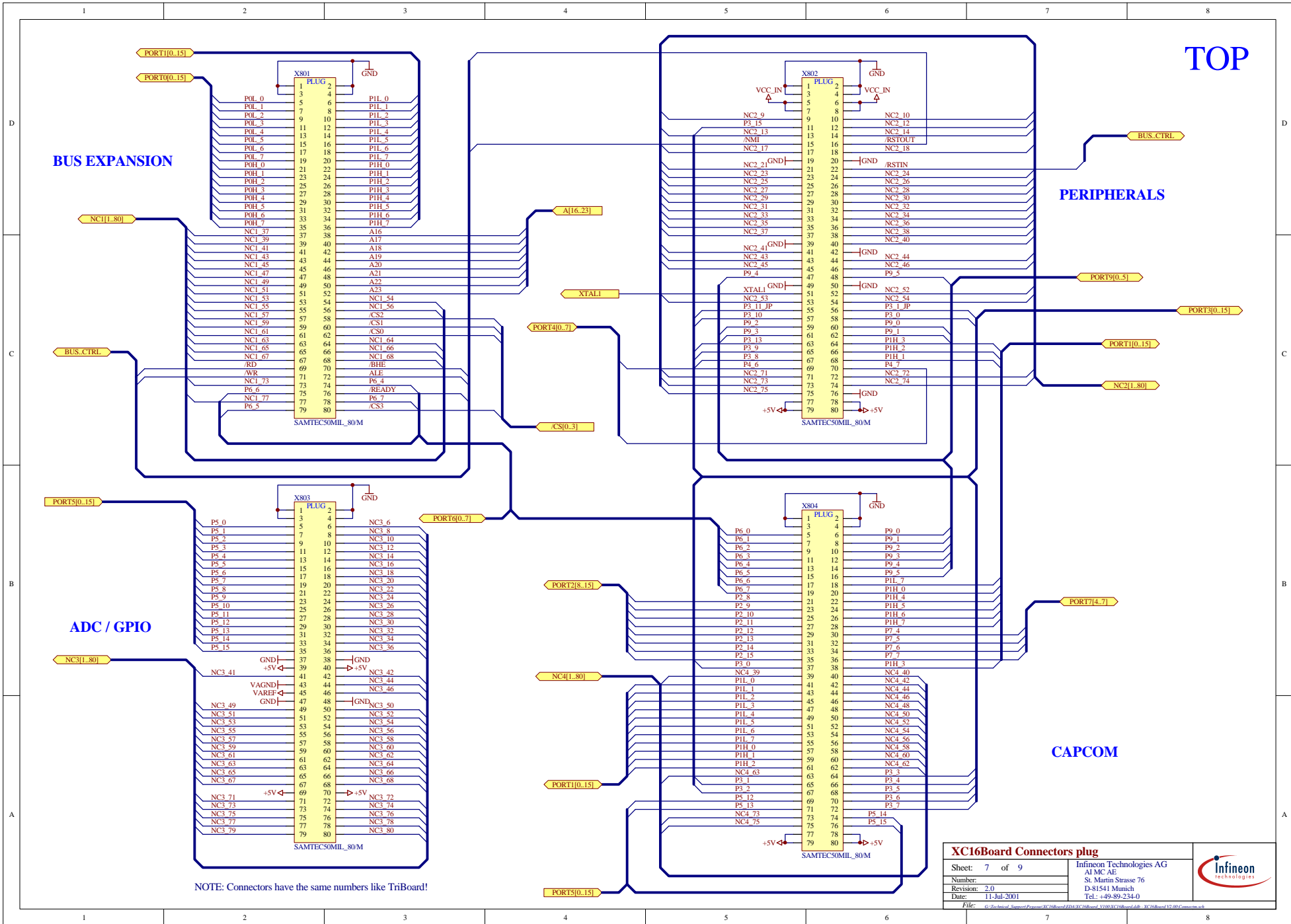

NOTE: Connectors have the same numbers like TriBoard!

XC16Board Connectors plug	
Sheet: 7 of 9	Infinitec Technologies AG
Number: AI MC AE	St. Martin Strasse 76
Revision: 2.0	D-81541 Munich
Date: 11-Jul-2001	Tel.: +49-89-234-0



File: G:\Technical Support\Processors\XC16Board\EDA\XC16Board_V100\XC16Board.ddb, XC16Board_V1.00\Connectors.plg

BOTTOM

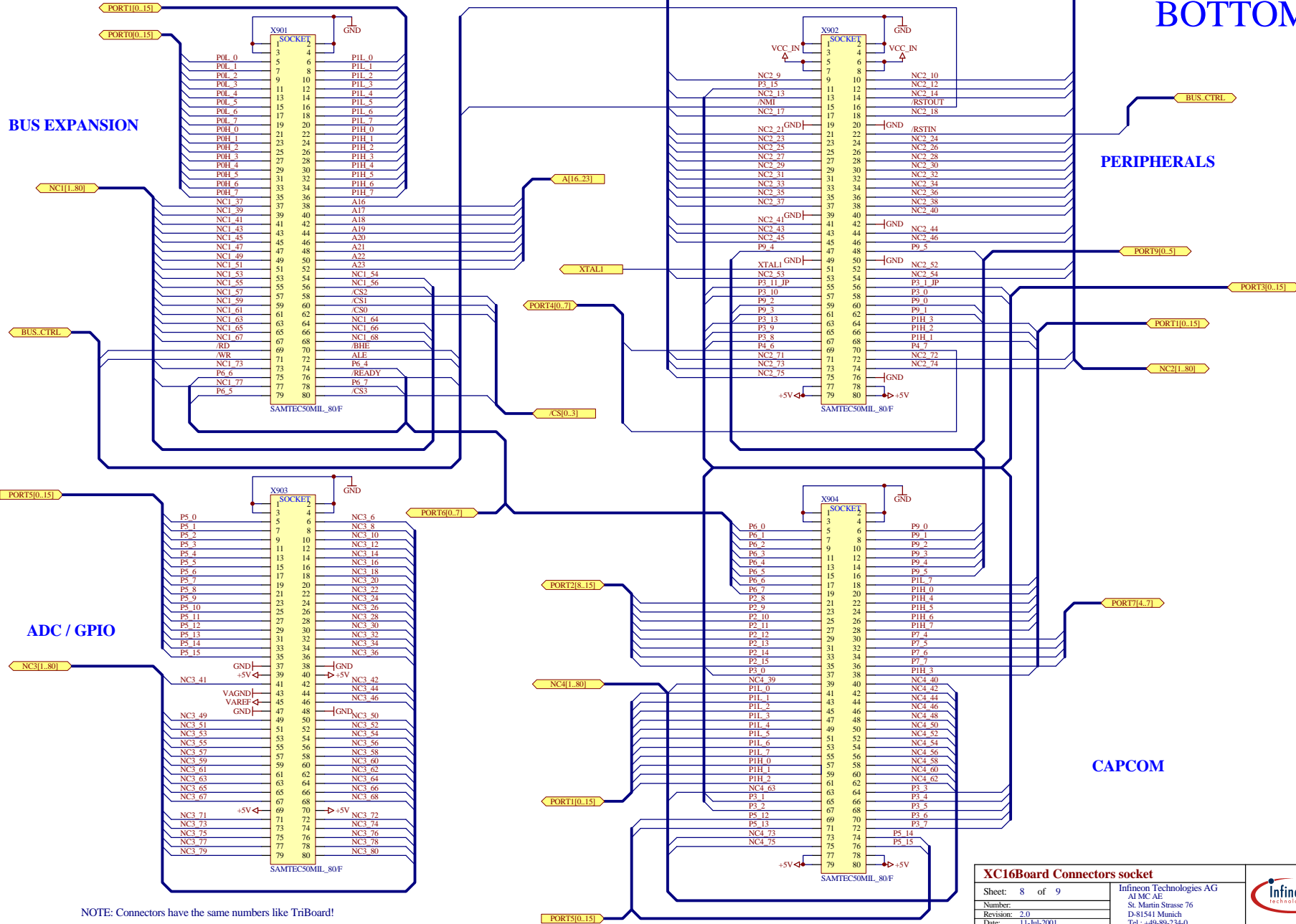

XC16Board Connectors socket	
Sheet: 8 of 9	Infineon Technologies AG
Number: AI MC AE	St. Martin Strasse 76
Revision: 2.0	D-81541 Munich
Date: 11-Jul-2001	Tel.: +49-89-234-0
	