

DELAYED SWEEP OSCILLOSCOPE

# CS-2075

70MHz  
QUAD-TRACE OSCILLOSCOPE

INSTRUCTION MANUAL



# TRIO

# CONTENTS

|   |    |  |    |
|---|----|--|----|
| <b>SAFETY</b> .....                     | 2  | FREQUENCY MEASUREMENTS.....            | 20 |
| <b>FEATURES</b> .....                   | 3  | PULSE WIDTH MEASUREMENTS .....         | 21 |
| <b>SPECIFICATIONS</b> .....             | 3  | PULSE RISETIME AND FALLTIME            |    |
| <b>PREPARATION FOR USE</b> .....        | 6  | MEASUREMENTS.....                      | 21 |
| <b>CONTROLS AND INDICATORS</b>          |    | TIME DIFFERENCE MEASUREMENTS .....     | 22 |
| FRONT PANEL.....                        | 7  | PHASE DIFFERENCE MEASUREMENTS .....    | 23 |
| REAR PANEL.....                         | 13 | RELATIVE MEASUREMENTS .....            | 23 |
| <b>OPERATION</b>                        |    | PULSE JITTER MEASUREMENTS.....         | 25 |
| [1] NORMAL SWEEP DISPLAY OPERATION..... | 14 | SWEEP MULTIPLICATION .....             | 25 |
| [2] MAGNIFIED SWEEP OPERATION .....     | 15 | DELAYED SWEEP TIME MEASUREMENTS.....   | 26 |
| [3] DELAYED SWEEP OPERATION.....        | 15 | PULSE WIDTH MEASUREMENTS USING         |    |
| [4] ALTERNATING SWEEP OPERATION .....   | 16 | DELAYED SWEEP .....                    | 26 |
| [5] X-Y OPERATION.....                  | 16 | FREQUENCY MEASUREMENTS USING           |    |
| [6] SINGLE SWEEP OPERATION .....        | 16 | DELAYED SWEEP.....                     | 27 |
| [7] DUAL AND QUAD TRACE OPERATION ..... | 16 | PULSE REPETITION TIME .....            | 27 |
| [8] CASCADED OPERATION .....            | 17 | USING DELAYED SWEEP FOR MEASUREMENT    |    |
| <b>APPLICATION</b>                      |    | OF RISETIMES AND FALLTIMES.....        | 28 |
| PROBE COMPENSATION .....                | 18 | TIME DIFFERENCE MEASUREMENTS           |    |
| TRACE ROTATION COMPENSATION.....        | 18 | USING DELAYED SWEEP .....              | 28 |
| DC VOLTAGE MEASUREMENTS.....            | 18 | X-Y OPERATION.....                     | 29 |
| MEASUREMENT OF THE VOLTAGE BETWEEN      |    | QUAD TRACE APPLICATION .....           | 30 |
| TWO POINTS ON A WAVEFORM.....           | 19 | <b>ACCESSORIES</b>                     |    |
| ELIMINATION OF UNDESIRED SIGNAL         |    | STANDARD ACCESSORIES INCLUDED .....    | 31 |
| COMPONENTS.....                         | 19 | INSTALLING PROBE HOLDER.....           | 31 |
| TIME MEASUREMENTS .....                 | 20 | OPTIONAL ACCESSORIES.....              | 31 |
|   |    | MOUNTING THE PROBE POUCH (MC-78) ..... | 32 |

## SAFETY

### Symbol in This Manual



This symbol indicates where applicable cautionary or other information is to be found.

### Power Source

This equipment operates from a power source that does not apply more than 250V rms between the supply conductors or between either supply conductor and ground. A protective ground connection by way of the grounding conductor in the power cord is essential for safe operation.

### Grounding the Product

This equipment is grounded through the grounding conductor of the power cord. To avoid electrical shock plug the power cord into a properly wired receptacle before connecting to the equipment input or output terminals.

### Use the Proper Power Cord

Use only the power cord and connector specified for your product.

### Use the Proper Fuse

To avoid fire hazard, use a fuse of the correct type.

### Do not Operate in Explosive Atmospheres

To avoid explosion, do not operate this product in an explosive atmosphere.

### Do not Remove cover or Panel

To avoid personal injury, do not remove the cover or panel. Refer servicing to qualified personnel.

## FEATURES

- Small and compact with high 1 mV/div sensitivity and 70 MHz bandwidth (1 mV/div when X5 GAIN function is used and 500  $\mu$ V/div for cascaded operation, channel 1 to channel 2).
- Bright 150 mm rectangular CRT with an internal graticule and a 12 kV accelerating potential.
- Vertical axis is capable of single, dual as well as quad-trace display.
- The 20 MHz bandwidth limiter incorporated eliminates high-frequency noises and stabilizes signal waveforms displayed.
- Single sweep, X10 magnification, delayed sweep and alternating sweep capability are provided.
- Fast 50ns/div sweep speed (5ns/div with X10 magnification).

- Accuracies of vertical axis and horizontal sweeping are as high as  $\pm 2\%$  at 10 ~ 35°C.
- The VIDEO synchronization circuit permits to observe video signal easily.
- The dual intensity control circuit permits to vary intensities separately for A and B sweeps.
- A switching type power supply provides stable operation with varying power sources (90V ~ 264V).
- A convenient channel 1 sampling output is provided.
- CPU controlled switching with LED lighted pushbutton switches provides easy. The LED of the switches indicate as follows when supplying power starts.

Vertical MODE : CH1  
 HORIZ DISPLAY : A  
 TRIG MODE : AUTO

## SPECIFICATIONS

### CRT

Model: 150LTM31  
 Type: Rectangular, with internal graticule  
 Accelerating potential: 12kV  
 Display area: 8 div x 10 div (1 div = 1 cm)

### VERTICAL AXIS (Channel 1 and Channel 2 identical specifications)

Sensitivity: 5mV/div to 5V/div (X1 mode)  
 1 mV/div to 1V/div (X5 mode)  
 500 $\mu$ V/div (Cascaded operation, CH1 to CH2)  
 Accuracy:  $\pm 2\%$  (10 ~ 35°C)  
 $\pm 5\%$  (0 ~ 50°C)  
 $\pm 8\%$  (Cascaded operation, CH1 to CH2)  
 Attenuator: 5mV/div to 5V/div in 1-2-5 sequence, all 10 ranges with fine adjustment between steps.  
 Input resistance: 1 M $\Omega$   $\pm$  1%  
 Input capacitance: Approx 22pF  
 Frequency response DC: DC to 70 MHz (-3 dB)  
 DC to 90 MHz (-6 dB)  
 DC to 40 MHz (-3 dB)  
 (Cascaded operation, CH1 to CH2)  
 DC to 50 MHz (-3 dB) (X5 mode)

AC: 5 Hz to 70 MHz (-3 dB)  
 5 Hz to 90 MHz (-6 dB)  
 7 Hz to 40 MHz (-3 dB), (Cascaded operation, CH1 to CH2)  
 5 Hz to 50 MHz (-3 dB) (X5 mode)

Risetime: 5ns (X1 mode)  
 7ns (X5 mode)  
 Signal delay time: Approx 10ns as displayed on CRT screen  
 Crosstalk: -40 dB minimum  
 Operating modes:  
 CH1 CH1, single trace  
 CH2 CH2, single trace  
 DUAL CH1 and CH2, dual trace  
 ADD CH1 + CH2 (added) display  
 QUAD CH1 ~ CH4, quad trace  
 ALT Dual or quad trace alternating  
 CHOP Dual or quad trace chopped  
 CHOP frequency: Approx 250 kHz  
 Channel polarity: Normal or inverted, CH 2 only inverted

▲ Maximum input voltage: 800 Vp-p or 400V (dc + ac peak)

# SPECIFICATIONS

Maximum undistorted amplitude: 8 divisions, minimum (DC to 70 MHz)

Bandwidth limiting: Vertical system bandwidth with the 20 MHz BW pushbutton switch pushed is approximately 20 MHz

## VERTICAL AXIS (Channel 3 and Channel 4 common specifications)

Sensitivity: 0.1V/div,  $\pm 2\%$

Input resistance:  $1\text{ M}\Omega \pm 1\%$

Input capacitance: Approx. 22 pF

Input coupling mode: DC only

Frequency response: DC to 70 MHz (-3 dB)  
DC to 90 MHz (-6 dB)

Risetime: 5ns

Signal delay time: Same as CH1 and CH2

Maximum allowable voltage

DC component:  $\pm 0.5\text{V}$  or less (ac + dc)

AC component: 1 Vp-p or less

Δ Maximum input voltage: 400V (dc + ac peak)

## HORIZONTAL AXIS (Channel 2 input)

Modes: X-Y mode is switch selectable (HORIZ DISPLAY)

X-Y mode: CH1: Y-axis  
CH2: X-axis

Sensitivity: Same as CH2

Accuracy: Same as CH2

Input resistance: Same as CH2

Input capacitance: Same as CH2

Frequency response:

DC: DC to 5 MHz (-3 dB)  
DC to 7 MHz (-6 dB)

AC: 5 Hz to 5 MHz (-3 dB)  
5 Hz to 7 MHz (-6 dB)

X-Y phase difference: Less than 3° at 100 kHz

## SWEEP

Modes (switchable with the HORIZ DISPLAY switch):

A: A sweep

ALT: B sweep waveform is displayed as an intensified portion of the A sweep and B sweep alternating

A-INT-B: B sweep waveform is displayed as an intensified portion of the A sweep.

B DLY'D: Delayed B sweep

X-Y: X-Y display mode

A sweep time: 50 ns/div to 0.5s/div in 22 ranges, in 1-2-5 sequence, vernier control provides

fully adjustable sweep time between steps.

B sweep time: 50ns/div to 50ms/div in 19 ranges, in 1-2-5 sequence.

Accuracy:  $\pm 2\%$  (10 ~ 35°C)  
 $\pm 6\%$  (0 ~ 50°C)

Sweep magnification:  $X10 \pm 5\%$  (10 ~ 35°C)  
 $\pm 7\%$  (0 ~ 50°C)

Linearity: 50ns/div to 0.5s/div  $\pm 3\%$  ( $\pm 5\%$  with X10 magnification)

HOLD OFF: Continuously adjustable for A sweep from NORM to X5

Trace separation: B positionable up to 4 divisions separated from A sweep, continuously adjustable.

Delay method: Continuous delay, Trigger delay

Delay time: 0.2 to 10 times the sweep time from 200ns to 0.5s, continuously adjustable.

Time difference measurement accuracy:  $\pm 2\%$  (10 ~ 35°C)  
 $\pm 4\%$  (0 ~ 50°C)

Delay jitter: 1/20000 of the full scale sweep time.

## TRIGGERING

### A TRIG

A trigger modes: AUTO, NORM, SINGLE

Trigger source: V MODE, CH1, CH2, EXT CH3

Coupling modes: AC, LF<sub>REJ</sub>, HF<sub>REJ</sub>, DC, VIDEO

VIDEO-LINE sync automatically selected at sweep times of 50  $\mu\text{s}$ /div to 50ns/div.

VIDEO-FRAME sync automatically selected at sweep times of 0.5s/div to 0.1ms/div.

Trigger level:  $\pm 90^\circ$  adjustable

Polarity: +/-

# SPECIFICATIONS

## B TRIG

Trigger source: CH1, CH2, EXT CH4  
STARTS AFTER DELAY

Coupling modes: AC only

Trigger level:  $\pm 90^\circ$  adjustable

Polarity: +/-

## TRIGGER SENSITIVITY (A AND B)

| COUPLING    | FREQ RANGE   | MINIMUM SYNC AMPLITUDE |        |
|-------------|--|------------------------|--------|
|             |  | INT                    | EXT    |
| DC          | DC ~ 20 MHz  | 0.5 div                | 50 mV  |
|             | DC ~ 70 MHz  | 1.5 div                | 210 mV |
| AC          | Same as for DC but with increased minimum level for below 20 Hz. |                        |        |
| AC<br>HFREJ | Increased minimum level below 20 Hz and above 30 kHz.            |                        |        |
| AC<br>LFREJ | Increased minimum level below 30 kHz.                            |                        |        |
| VIDEO       | FRAME/LINE   | 0.5 div                | 50 mV  |

AUTO: Same as above specifications for above 50 Hz.

Jitter: 1 ns maximum  
(At 70 MHz) 5 ns/div (X10 MAG on)

## CALIBRATING VOLTAGE

1 kHz  $\pm 3\%$  Positive square wave  
1 Vp-p  $\pm 1\%$  (10 ~ 35°C)  
 $\pm 2\%$  (0 ~ 50°C)

## INTENSITY MODULATION

Input signal: TTL level, intensity decreasing with more positive levels

Input impedance: Approx. 10 k $\Omega$

Usable frequency range: DC to 10 MHz

△ Maximum input voltage: 50V (dc + ac peak)

## VERTICAL AXIS OUTPUT (Sampled CH1 output)

Output voltage: 50 mVp-p/div (into 50 $\Omega$  load)

Output impedance: Approx. 50 $\Omega$

Frequency response: DC to 70 MHz (-3 dB)  
(into 50 $\Omega$  load)

## TRACE ROTATION

Electrical, adjustable

## POWER SUPPLY

Line voltage: 90 ~ 264V

Line frequency: 45 ~ 400 Hz

Power consumption: Approx. 55W (at 100V, 50 Hz)

## DIMENSIONS

Width: 284 mm (328 mm)

Height: 138 mm (150 mm)

Depth: 400 mm (471 mm)

( ) dimensions include protrusions from basic case outline dimensions.

## WEIGHT

7.4 kg

## ACCESSORIES

PC-29 Probes ..... 2

Instruction manual..... 1

AC power cord ..... 1

Probe holder ..... 1

## OPTION

Accessory bag (MC-78)

Panel cover (MD-85)

## ENVIRONMENT

Operating temperature and humidity for guaranteed specifications: 10 ~ 35°C, 85% maximum RH

Full operating range: 0 ~ 50°C, 90% maximum RH

Storage temperature and humidity range: -20 ~ +70°C  
80% maximum

Altitude:

Operating: 5000 m

Non-operating: 12000 m

■ Circuit and ratings are subject to change without notice due to developments in technology.

# PREPARATION FOR USE

## SAFETY

Before connecting the instrument to a power source, carefully read the following information, then verify that the proper power cord is used and the proper line fuse is installed for power source. If the power source is not applied to your product, contact your dealer. If the power cord is not applied for specified voltage, there is always a certain amount of danger from electric shock.

### Line voltage

This instrument operates using ac-power input voltages that 90V to 264V at frequencies from 45 Hz to 400 Hz.

### Power cord

The ground wire of the 3-wire ac power plug places the chassis and housing of the oscilloscope at earth ground. Do not attempt to defeat the ground wire connection or float the oscilloscope; to do so may pose a great safety hazard. The appropriate power cord is supplied by an option that is specified when the instrument is ordered.

The optional power cord are shown in Fig 40.

### Line fuse

The fuse holder is located on the rear panel and contains the line fuse. Verify that the proper fuse is installed by replacing the line fuse.

## EQUIPMENT PROTECTION

1. Never allow a small spot of high brilliance to remain stationary on the screen for more than a few seconds. The screen may become permanently burned. A spot will occur only when the scope is set up for X-Y operation and no signal is applied. Either reduce the intensity so the spot is barely visible, switch back to normal sweep operation when no signal is applied, or set up the scope for spot blanking.
2. Never cover the ventilating holes on the top of the oscilloscope, as this will increase the operating temperature inside the case.
3. Never apply more than the maximum rating to the oscilloscope input jacks.  
CH1, CH2 INPUT jacks: 800 V<sub>p-p</sub> or 400V (dc + ac peak)  
CH3, CH4 INPUT jacks: 400 V (dc + ac peak)  
Z axis INPUT jack: 50V (dc + ac peak)  
Never apply external voltage to the oscilloscope output terminals.
4. Always connect a cable from the earth ground (GND) jack of the oscilloscope to the chassis of the equipment under test. Without this caution, the entire current for the equipment under test may be drawn through the probe clip leads under certain circumstances. Such conditions could also pose a safety hazard, which the ground cable will prevent.

5. Always use the probe ground clips for best results. Do not use an external ground wire in lieu of the probe ground clips, as undesired signals may be introduced.
6. Operation adjacent to equipment which produces strong ac magnetic fields should be avoided where possible. This includes such devices as large power supplies, transformers, electric motors, etc., that are often found in an industrial environment. Strong magnetic shields can exceed the practical CRT magnetic shielding limits and result interference and distortion.
7. Probe compensation adjustment matches the probe to the input of the scope. For best results, compensation of probe should be adjusted initially, then the same probe always used with the input of scope. Probe compensation should be readjusted whenever a probe from a different scope is used.
8. The LEDs of the switches indicate as follows when supplying power starts.  
Vertical MODE: CH1,  
HORIZ DISPLAY: A  
TRIG MODE: AUTO

# CONTROLS AND INDICATORS

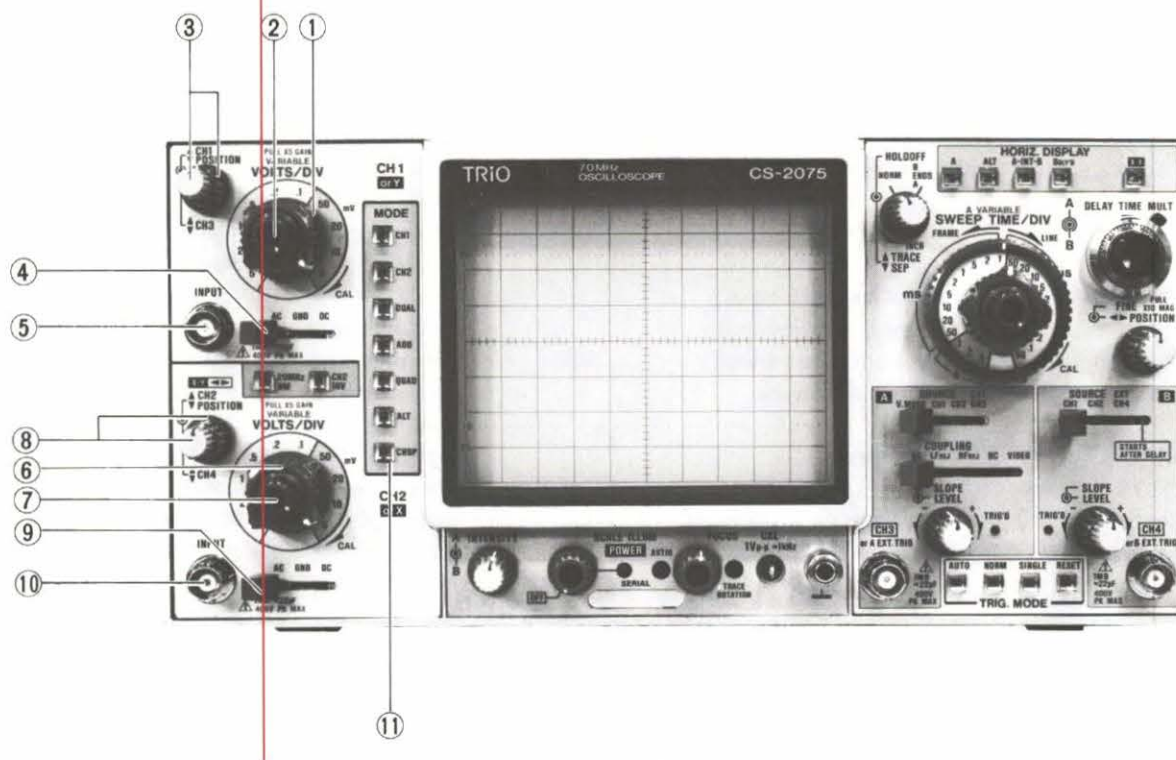

Fig. 1

## FRONT PANEL

### VERTICAL AXIS CONTROL

#### ① VOLTS/DIV Control

Vertical attenuator for channel 1; provides step adjustment of vertical sensitivity. When the VARIABLE control is turned to the CAL position, the vertical sensitivity is calibrated in 10 steps from 5V/div to 5 mV/div.

For X-Y operation this control provides step adjustment of vertical sensitivity.

#### ② VARIABLE, PULL X5 GAIN Controls

Rotation provides fine control of channel 1 vertical sensitivity. In the fully clockwise (CAL) position, the vertical attenuator is calibrated. For X-Y operation, this control serves as the Y axis attenuation fine adjustment.

#### PULL X5 GAIN;

When pulled out, the VOLTS/DIV setting is multiplied by five and for X-Y operation the Y-axis sensitivity is multiplied accordingly. In X5 GAIN mode, the vertical gain is increased and the trace becomes thickness.

#### ③ ▲ CH1 POSITION, ▼ CH3 Controls

##### ▲ CH1 POSITION;

Rotation adjusts vertical position of channel 1 trace. In X-Y operation, rotation adjusts vertical position of display.

##### ▼ CH3;

Rotation adjusts vertical position of channel 3 trace on the screen.

#### ④ AC-GND-DC switch

Three-position lever switch which operates as follows:

AC: Blocks dc component of channel 1 input signal.

GND: Opens signal path and grounds input to vertical amplifier. This provides a zero-signal base line, the position of which can be used as a reference when performing dc measurements.

DC: Direct input of ac and dc component of channel 1 input signal.

#### ⑤ INPUT Jack

Vertical input for channel 1 trace in normal sweep operation. Vertical input for X-Y operation.

#### ⑥ VOLTS/DIV Control

Vertical attenuator for channel 2; provides step adjustment of vertical sensitivity, VARIABLE control is turned to the CAL position, the vertical sensitivity calibrated in 10 steps from 5V/div to 5mV/div. For X-Y operation the control provides step adjustment of horizontal sensitivity.

# CONTROLS AND INDICATORS

## ⑦ VARIABLE, PULL X5 GAIN Controls

### VARIABLE;

Rotation provides fine control of channel 2 vertical sensitivity. In the fully clockwise (CAL) position, the vertical attenuator is calibrated. For X-Y operation, this control serves as the X axis attenuation fine adjustment.

### PULL X5 GAIN;

When pulled out, the VOLTS/DIV setting is multiplied by five and for X-Y operation the X-axis sensitivity is multiplied accordingly. In X5 GAIN mode, the vertical gain is increased and the trace becomes thickness.

## ⑧ CH2 $\updownarrow$ POSITION X-Y $\leftarrow\rightarrow$ , $\updownarrow$ CH4 Controls

### $\updownarrow$ CH2 POSITION;

Rotation adjusts vertical position of channel 2 trace. In X-Y operation adjusts horizontal position of display.

### $\updownarrow$ CH4;

Rotation adjusts vertical position of channel 4 trace on the screen.

## ⑨ AC-GND-DC Switch

Three-position lever switch which operates as follows:

AC: Blocks dc component of channel 2 input signal.

GND: Opens signal path and grounds input to vertical amplifier. This provides a zero-signal base line, the position of which can be used as a reference when performing dc measurements.

DC: Direct input of ac and dc component of channel 2 input signal.

## ⑩ INPUT Jack

Vertical input for channel 2 trace in normal sweep operation. Horizontal input in X-Y operation.

## ⑪ MODE Switch Assembly

Used to select the basic operating modes of the oscilloscope. LED's indicate what mode has been selected.

CH1: Only the input signal to channel 1 is displayed as a single trace.

CH2: Only the input signal to channel 2 is displayed as a single trace.

DUAL: When engaged this button, if either ALT or CHOP switch is pushed in, dual trace mode presents traces of channel 1, channel 2 input waveforms.

ADD: Channel 1 and channel 2 input signals are added and the sum is displayed as a single trace. When the CH2 INV button is engaged, the waveform from channel 2 is subtracted from the channel 1 waveform and the difference is displayed as a single trace.

QUAD: When engaged this button, if either ALT or CHOP switch is pushed in, quad trace mode presents traces of channel 1 through channel 4 input waveforms

ALT: Alternate sweep is selected regardless of sweep time as dual trace (channel 1 and channel 2) or quad trace (channel 1 through channel 4)

CHOP: Chop sweep is selected regardless of sweep time at approximately 250 kHz as dual trace (channel 1 and channel 2) or quad trace (channel 1 through channel 4).

CH2 INV: In the NORM position (button released), the channel 2 signal is non-inverted. In the INV position (button engaged), the channel 2 signal is inverted.

20 MHzBW: Limits the vertical bandwidth to approximately 20 MHz when engaged this button.

### NOTE:

The various vertical mode settings are related to horizontal mode and trigger source. See the sections on HORIZ DISPLAY and SOURCE for a description of this relationship.



# CONTROLS AND INDICATORS

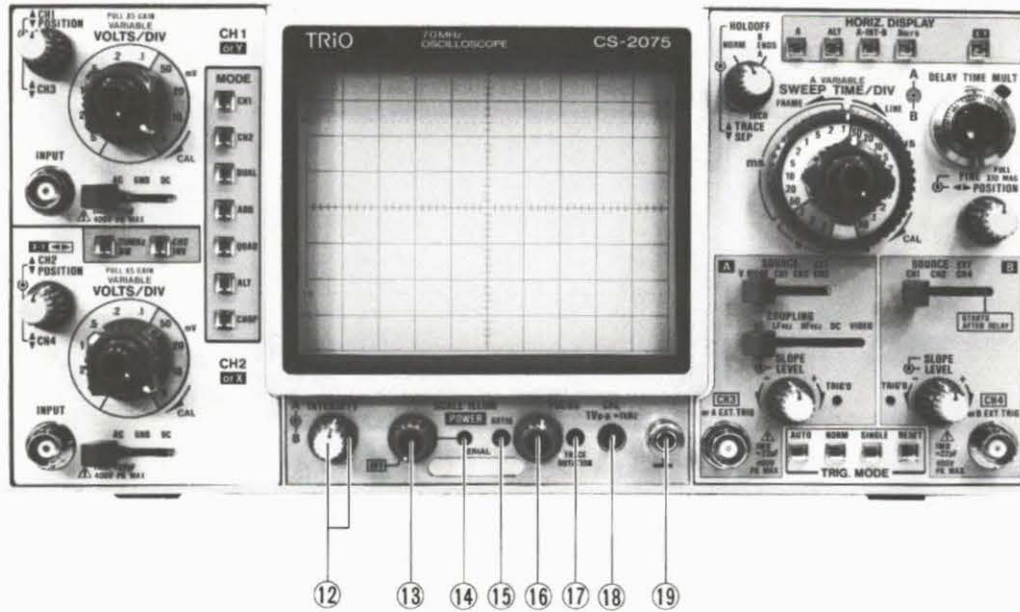

Fig. 2

## POWER SUPPLY/CRT DISPLAY CONTROLS

- ⑫ **A INTENSITY, B INTENSITY Controls**  
 Allows adjustment of intensity for the A sweep and B sweep respectively.  
**A INTENSITY;**  
 Adjusts the trace intensity for the A sweep and the display intensity for X-Y operation.  
**B INTENSITY;**  
 Adjusts the intensity of the B sweep.
- ⑬ **POWER, SCALE ILLUM Controls**  
 Fully counterclockwise rotation (off position) turns off oscilloscope. Clockwise rotation turns on oscilloscope. Further clockwise rotation of the control increases the illumination level of scale.
- ⑭ **LED Pilot Lamp**  
 Indicates that the power supply has been turned on.
- ⑮ **ASTIG Control**  
 Pull out and rotate this knob. Astigmatism adjustment provides optimum spot roundness when used in conjunction with FOCUS control regardless intensity control.
- ⑯ **FOCUS Control**  
 Used to adjust the trace for optimum focus. Auto-focus circuit keeps waveform in focus with changes in intensity.
- ⑰ **TRACE ROTATION Control**  
 Electrically rotates trace to horizontal position. Strong magnetic fields may cause the trace to be tilted. The degree of tilt may vary as the scope is moved from one location to another. In these cases, adjust this control.
- ⑱ **CAL, 1Vp-p,  $\approx$  1 kHz Terminal**  
 Provides 1kHz, 1Volt peak-to-peak square wave signal. This is useful for probe compensation adjustment.
- ⑲ **⏏ GND Terminal/Binding post.**  
 Ground terminal – use it to connect the instrument to the earth ground.

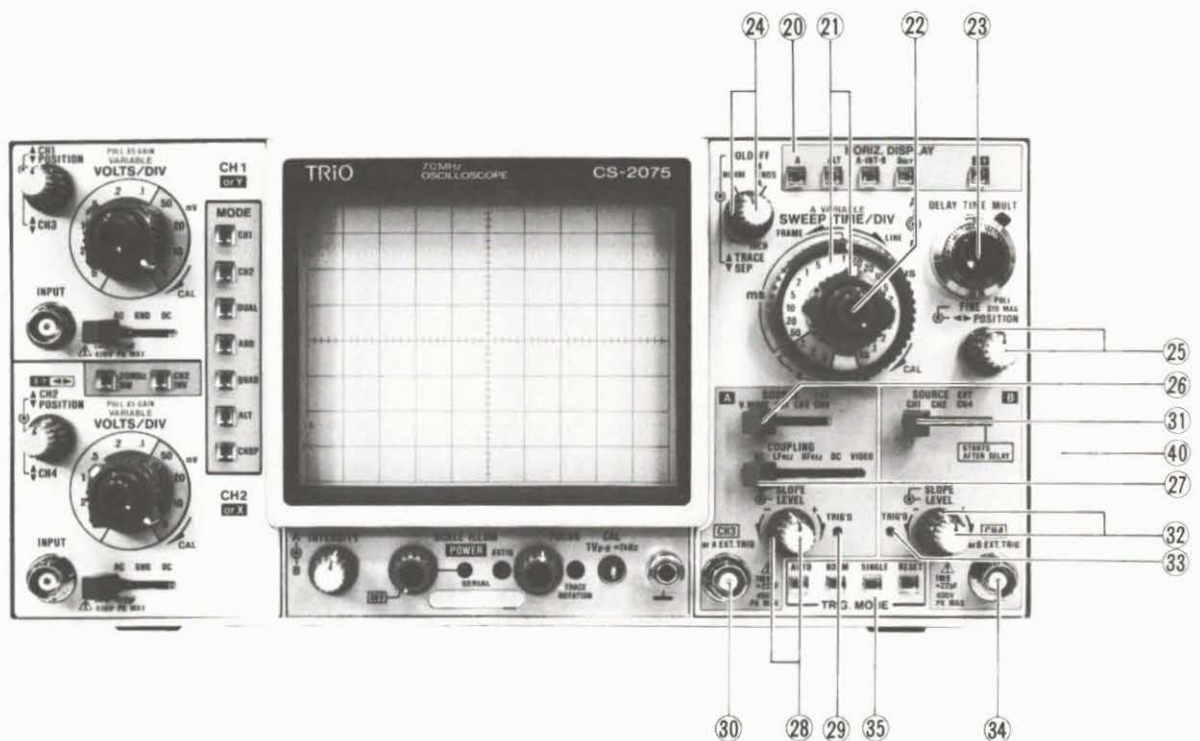

Fig. 3

## HORIZONTAL AXIS CONTROLS

- ⑳ **HORIZ DISPLAY Switch assembly**  
Used to select the horizontal display mode. LED's indicate what mode has been selected.
- A: Only A sweep is operative with the B sweep dormant.
- ALT: A sweep alternates with the B sweep. For this mode of operation, the B sweep appears as an intensified section on the A sweep.
- A-INT-B: Duration of the B sweep appears as an intensified section on the A sweep.
- B DLY'D: Only delayed B sweep is operative.
- X-Y: Channel 1 becomes the Y-axis and channel 2 becomes the X-axis for X-Y operation. The settings of the vertical MODE and TRIG MODE switches have no effect.
- ㉑ **A SWEEP TIME/DIV, B SWEEP TIME/DIV Controls**  
A SWEEP TIME/DIV;  
Horizontal coarse A sweep time selector. Selects calibrated sweep times of 50 ns/div to 0.5 s/div in 22 steps when A VARIABLE control ㉒ is set to CAL position (fully clockwise).
- B SWEEP TIME/DIV;  
Horizontal coarse B sweep time selector. Selects sweep times of 50 ns/div to 50 ms/div in 19 steps. B sweep time selector is constructed to make it possible to set the B sweep time slower than A sweep time. No fine adjustment is available for the B sweep time.
- ㉒ **A VARIABLE Control**  
Fine A sweep time adjustment. In the fully clockwise (CAL) position, the A sweep time is calibrated.
- ㉓ **DELAY TIME MULT Control**  
Adjusts the start time of the B sweep to some delay time after the start of the A sweep. The delay time may be set to values between 0.2 and 10 times the setting of the A SWEEP TIME/DIV control.

# CONTROLS AND INDICATORS

## ②④ ▲ TRACE SEP, HOLDOFF Controls

### ▲ TRACE SEP;

Adjusts vertical separation between A sweep and B sweep (control has effect only in the ALT of HORIZ DISPLAY).

Counterclockwise rotation increases separation; B sweep moves down with respect to A sweep up to 4 divisions. In this case, HOLDOFF control has no effect.

### HOLDOFF;

Rotation adjusts holdoff (trigger inhibit period beyond sweep duration). Counterclockwise rotation increases holdoff period from NORM to max more than five times before the B ENDS A position.

In the B ENDS A position (fully counterclockwise), the A sweep is reset at the end of the B sweep. And therefore intensity of B sweep increases to provide the A sweep. B ENDS A mode is applicable to the ALT, A-INT-B and B DLY'D modes of HORIZ DISPLAY.

## ②⑤ ◀▶ POSITION, FINE, PULL X10 MAG Controls

### ◀▶ POSITION;

Rotation adjusts horizontal position of trace.

### FINE, PULL X10 MAG;

Rotation becomes fine adjustment of horizontal position of trace. Selects  $\times 10$  sweep magnification (PULL  $\times 10$  MAG) when pulled out.

## TRIGGER SOURCE CONTROLS

## ②⑥ SOURCE Switch

Four-position lever switch; selects triggering source for the A sweep, with following positions;

V. MODE: The trigger source for A sweep is determined by vertical MODE selection.

CH1: Channel 1 signal is used as a trigger source.

CH2: Channel 2 signal is used as a trigger source.

ADD: The algebraic sum of channel 1 and channel 2 signals is the trigger source. (If CH2 INV engaged, the difference becomes the trigger source.)

DUAL: For ALT mode the signals for CH1  
QUAD: through CH4 alternate as the trigger (ALT) source. For the CHOP mode the chopping (CHOP) signal becomes the trigger source.

## NOTE:

1. When the vertical MODE switch is selected to CHOP position, the display cannot be observed with the input since the chopping signal becomes the trigger source.
2. Synchronization is impossible when input signals are not applied to all channels with the vertical MODE switch set to DUAL or QUAD position.

CH1: A sweep is triggered by channel 1 signal regardless of vertical MODE selection.

CH2: A sweep is triggered by channel 2 signal regardless of vertical MODE selection.

EXT CH3: A sweep is triggered by channel 3 signal.

## ②⑦ COUPLING Switch

Five-position lever switch; selects coupling for A trigger signal.

AC: Trigger is ac coupled. Blocks dc component of input signal; most commonly used position.

LFREJ: Trigger is coupled through a high-pass filter to eliminate low frequency components for stable triggering of high frequency signals.

HFREJ: Trigger is coupled through a low-pass filter to eliminate high frequency components for a stable triggering of low frequency signals.

DC: Trigger is dc coupled for sync which includes the effects of dc components. For channel 3 and channel 4, the vertical position adjustment has no effect on the trigger point.

VIDEO: For synchronization of video signals. The position of the A SWEEP TIME/DIV control determines whether FRAME or LINE is to be synchronized. Settings between 0.5s and 0.1ms result in FRAME while those between 50  $\mu$ s and 50ns result in LINE sync.

## ②⑧ LEVEL, SLOPE Controls

LEVEL; Rotation adjusts point on waveform where A sweep starts. When COUPLING switch is selected in VIDEO, the trigger level adjustment has no effect.

# CONTROLS AND INDICATORS

SLOPE; Adjusts the slope of the A trigger signal.  
+equals most positive point of triggering and  
-equals most negative point of triggering.

## 29 TRIG'D Lamp

Green LED lights for duration of triggered A sweep; shows when trigger LEVEL control is properly set to obtain triggering.

## 30 CH3 or A EXT TRIG Jack

Input terminal of channel 3 signal or A external trigger signal. Channel 3 signal may be observed simultaneously with channel 1, 2 and 4 signals when the vertical MODE switch is selected in QUAD.

When the SOURCE control is set to EXT CH3, sweep is triggered by this input signal.

## 31 SOURCE Switch

Four-position lever switch; selects the triggering source for the B sweep, with following positions;

CH1: B sweep is triggered by channel 1 signal.

CH2: B sweep is triggered by channel 2 signal.

EXT CH4: B sweep is triggered by channel 4 signal.

STARTS AFTER DELAY:

B sweep starts immediately after the delay time selected by the DELAY TIME MULT and A SWEEP TIME/DIV controls, regardless of the trigger LEVEL setting. Even when this switch is in position with the TRIG MODE switch set to AUTO, turning the trigger LEVEL clockwise or counterclockwise release the trigger and set the scope to B STARTS AFTER DELAY operation.

## 32 LEVEL, SLOPE, Controls

LEVEL: Rotation adjusts point on waveform where B sweep starts.

SLOPE: Adjust the slope of the B trigger signal, +equals most positive point of triggering and -equals most negative point of triggering. For B trigger operation it must be set in its pushed-in position.

## 33 TRIG'D Lamp

Green LED lights for duration of triggered B sweep; shows when trigger LEVEL control is properly set to obtain triggering.

## 34 CH4 or B EXT TRIG Jack

Input terminal for the channel 4 signal or B external trigger signal. Channel 4 signal may be observed simultaneously with channel 1, 2 and 3 signals when the vertical MODE is selected in QUAD.

When the SOURCE switch is set to EXT CH4, sweep is triggered by this input signal.

## 35 TRIG MODE Switch

Push button switch assembly; selects triggering mode.

AUTO: Triggered sweep operation. When trigger signal is present, automatically generates sweep (free runs in absence of trigger signal.)

NORM: Normal triggered sweep operation. No trace is presented when a proper trigger signal is not applied.

SINGLE: Single sweep operation. Note that in this mode, simultaneous observation of both the A and B sweeps is not possible.

### NOTE:

For dual or quad trace, single sweep operation, vertical MODE must not be set to ALT. Use the CHOP mode instead.

RESET: When TRIG MODE switch is selected to SINGLE mode, pushing the RESET button initiates a single sweep which will begin when the next sync trigger occurs.

# CONTROLS AND INDICATORS

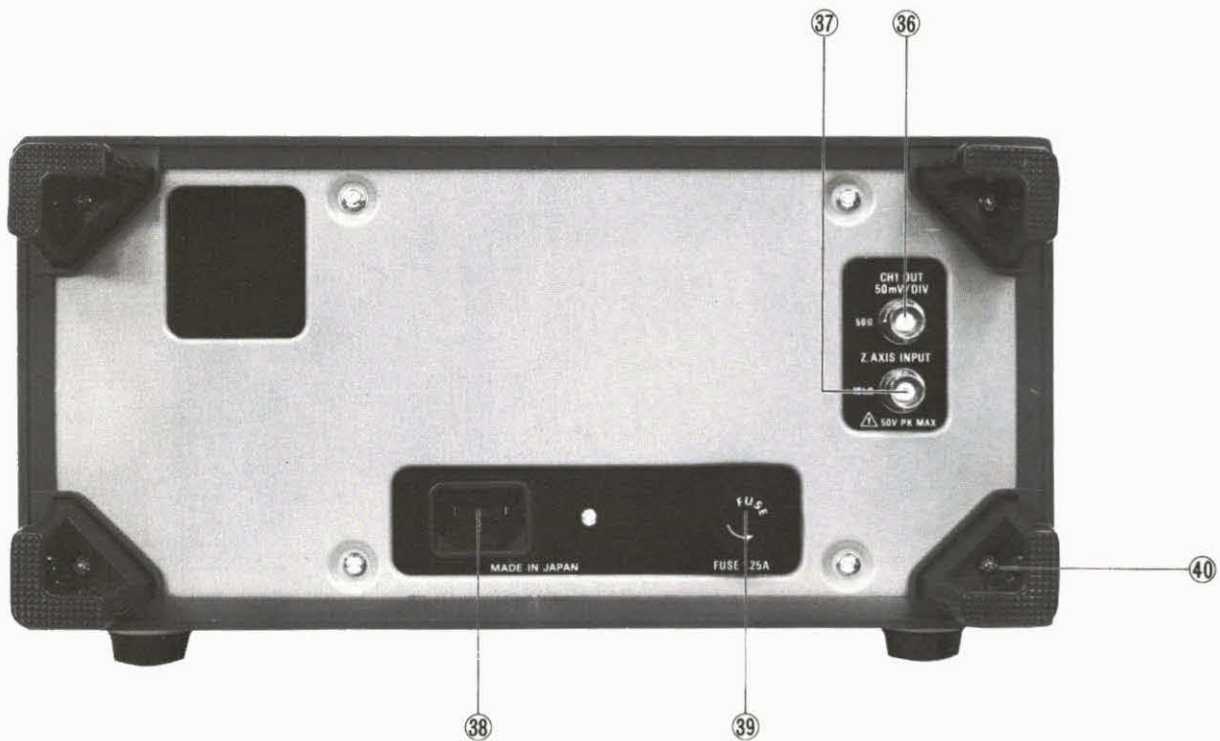

Fig. 4

## REAR PANEL

- ③⑥ **CH1 OUT Jack**  
Channel 1 vertical output signal connector. Ac coupled output connector. This connector is used to measure the frequency by connecting the frequency counter.
  - ③⑦ **Z. AXIS INPUT Jack**  
External intensity modulation input; TTL compatible. Positive voltage decreases brightness, negative voltage increases brightness.
  - ③⑧ **POWER LINE CONNECTOR**  
The input connector for the AC power cord.
  - ③⑨ **FUSE HOLDER**  
Contain the line fuse. Verify that the proper fuse is installed (1.2A).
  - ④⑩ **Feet**  
Rear feet support oscilloscope in face-up position and double as cord wrap for storing power cord.
- Handle**  
Carrying handle with comfortable molded finger grip also doubles as tilt stand. Locking detent each 15° allows adjustment of viewing angle.

# OPERATION

Before turning the scope on, set the front panel controls as follows, referring to the section on front panel in this manual.

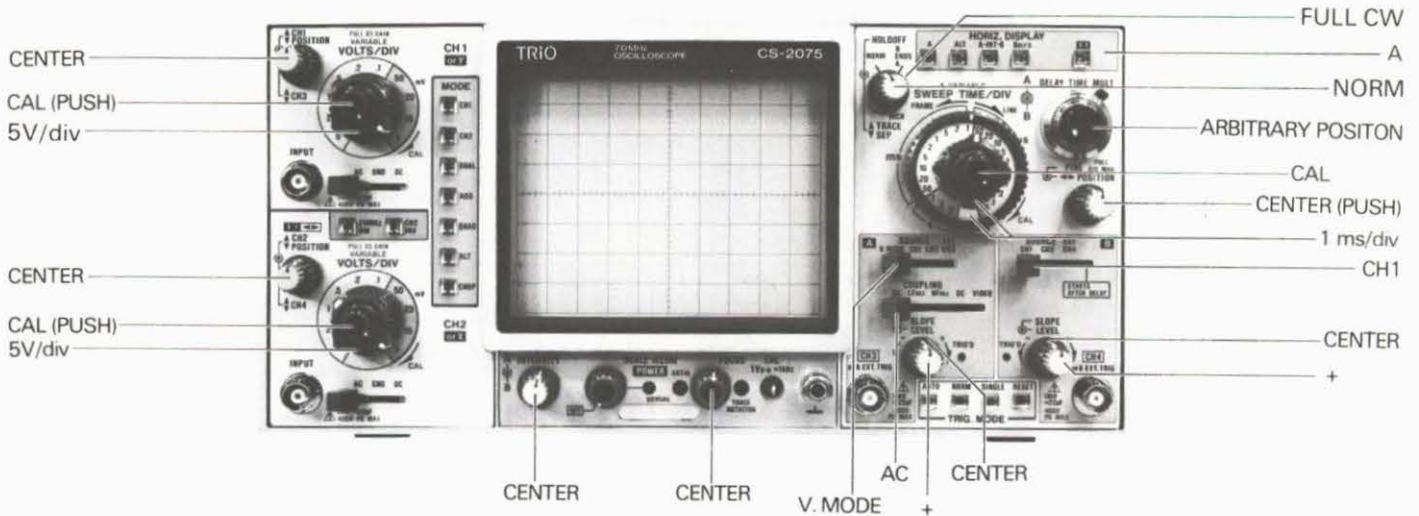

Fig. 5

## [1] NORMAL SWEEP DISPLAY OPERATION

1. Turn the POWER control ⑬ clockwise – the power supply will be turned on and the pilot lamp will light with the other LED's for the previously set vertical MODE ⑪, HORIZ DISPLAY ⑳ and TRIG MODE ㉓ also lighting.

Set these modes as follows:

Vertical MODE ⑪ : CH1  
 HORIZ DISPLAY ⑳ : A  
 TRIG MODE ㉓ : AUTO

2. The trace will appear in the center of the CRT display and can be adjusted by the channel 1  $\updownarrow$  POSITION ③ and  $\leftarrow \rightarrow$  POSITION ㉑ controls. Next, adjust the A INTENSITY ⑫ and, if necessary, the FOCUS ⑯ for ease of observation.

### 3. Vertical MODE

With vertical MODE ⑪ set to CH1, apply an input signal to the channel 1 INPUT ⑤ jack and adjust VOLTS/DIV ① control for a suitable size display of the waveform. Operation with a signal applied to the channel 1 INPUT ⑤ jack and the vertical MODE set to CH2 is similar to the above procedure. In the ADD mode, the algebraic sum of channel 1 + channel 2 is displayed. If the CH2 INV switch has been pressed, the algebraic difference of the two waveforms, channel 1 – channel 2 is displayed. If both channels are set to the same VOLTS/DIV, the sum or difference can be read directly in VOLTS/DIV from the CRT. The DUAL mode allows

simultaneous observation of channel 1 and channel 2 waveforms. In the DUAL mode, either the CHOP or ALT mode applies and must be selected. In the ALT mode, one sweep displays the channel 1 signal and the next sweep displays the channel 2 signal in an alternating sequence. In the CHOP mode, the sweep is chopped at an approximate 250 kHz rate and switched between channel 1 and channel 2. Note that in the CHOP mode of operation with the SOURCE ㉖ switch set to V MODE, the trigger source becomes the chopping signal itself, making waveform observation impossible. Use ALT mode instead in such cases, or select the SOURCE switch to CH1, CH2, or CH3. The QUAD mode is similar to the DUAL mode, except it allows simultaneous viewing of channel 1 thru channel 4 input signals, in either ALT or CHOP mode. The channel 3 and channel 4 POSITION controls ③ and ⑧ become effective in the QUAD mode for adjusting the vertical position of the channel 3 and channel 4 traces. The channel 3 and channel 4 INPUT signals are dc coupled and have a sensitivity of 0.1 V/div.

# OPERATION

## 4. Triggering

The SOURCE switch (26) selects the signal to be used as the sync trigger. When the V. MODE position is selected, the trigger source is dependent upon the vertical MODE selection. In this manner, each waveform being observed becomes its own trigger signal; e.g., when the vertical MODE is changed from CH1 to CH2, the source signal is also changed from CH1 to CH2. This also permits synchronization of waveforms (even without a timing relationship) in the DUAL and QUAD modes. However, when phase or timing comparison is desired in DUAL and QUAD modes, all waveforms must be triggered by the same source, and the V. MODE position is unsuitable. Also, as explained previously, CHOP cannot be used in conjunction with vertical MODE in DUAL or QUAD modes. If the SOURCE switch is set to the CH1 (or CH2) position, the channel 1 (or channel 2) input signal is the trigger source, regardless of the vertical MODE. CH1 (or CH2) is often used as the trigger source when timing comparison is desired. If the SOURCE switch is set to the CH3 position, the signal applied to the CH3 or A EXT TRIG jack becomes the trigger source. This signal must have a timing relationship to the displayed waveforms for a synchronized display. In QUAD mode, the signal applied to the CH3 or A EXT TRIG jack becomes both the trigger source and the displayed channel 3 signal.

After setting the SOURCE switch, adjust the LEVEL/SLOPE control (28) to set the trigger point. Sync is indicated by the green TRIG'D LED lighting.

As necessary to obtain a stable, synchronized display, adjust the HOLDOFF control (24) and COUPLING (27) switch.

5. Adjust the A SWEEP TIME/DIV control (21) for an appropriate display of the signal input. If required, use the A VARIABLE control (22) as well.
6. This completes the operating procedure for normal A sweep display.

## [2] MAGNIFIED SWEEP OPERATION

Since merely shortening the sweep time to magnify a portion of an observed waveform can result in the desired portion disappearing off the screen, such magnified display should be performed using the MAGNIFIED SWEEP.

Procedure:

Using the ◀▶ POSITION control, adjust the desired portion of waveform to the center of the CRT. Pull out the FINE PULL X10 MAG (25) control to magnify the display 10 times. For this type of display the sweep time is the SWEEP TIME/DIV setting divided by 10.

## [3] DELAYED SWEEP OPERATION

Delayed sweep operation is achieved by use of both the A sweep and the B sweep.

Procedure:

1. First select the HORIZ DISPLAY switch to A and adjust the scope for a normal waveform display.
2. Set the B SOURCE switch (31) to the STARTS AFTER DELAY. Select the HORIZ DISPLAY to the A-INT-B mode and a portion of the B sweep representing the B SWEEP TIME/DIV will appear as an intensified portion of the A sweep. The B sweep intensity is adjusted using the B INTENSITY control (12).
3. Shift the intensified portion of waveform (section to be magnified) along the A sweep by use of the DELAY TIME MULT (23).
4. Select the HORIZ DISPLAY switch to B DLY'D to display the A-INT-B intensified portion as a magnified B DLY'D sweep.

Delay Time (magnified portion) = DELAY TIME MULT setting  $\times$  A SWEEP TIME/DIV setting.

5. For STARTS AFTER DELAY operation, apparent jitter increases as magnification increases. To obtain a jitter free display, set the B SOURCE switch (31) in a position similar to that of corresponding for A SOURCE. In this mode the signal selected by the B SOURCE switch becomes the B trigger source, making use of the B trigger LEVEL (32) control to set the trigger point. B SOURCE, and LEVEL/SLOPE controls are set in a manner similar to that of the corresponding controls for A sweep.

A-INT-B Intensified zone to be magnified

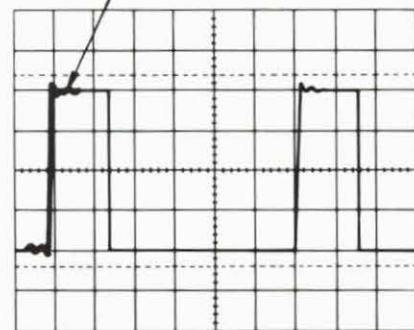

B DLY'D

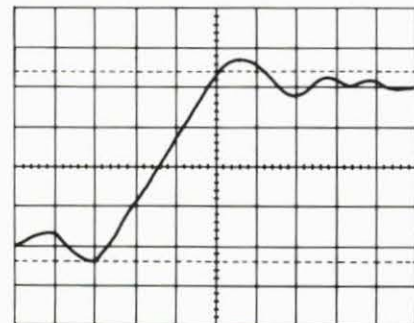

Fig. 6

# OPERATION

Note that for type of operation both the DELAY TIME MULT and trigger LEVEL affect the start of the B sweep so that the delay time is used as a reference point.

## [4] ALTERNATING SWEEP OPERATION

A sweep and B sweep are usable in an alternating mode making it possible to observe both the normal and magnified waveform simultaneously.

Procedure:

1. Select the HORIZ DISPLAY switch to A and adjust the scope for a normal waveform display.
2. Set the B SOURCE switch to STARTS AFTER DELAY and select the HORIZ DISPLAY to ALT. Adjust TRACE SEP ② for easy observation of both the A and B traces.

The upper trace is the non-magnified portion of the waveform with the magnified portion super-imposed as an intensified section. The lower waveform is the intensified portion displayed magnified.

B INTENSITY can be used to adjust the intensity of the super-imposed waveform.

3. The DELAY TIME MULT control can be used to continuously slide the magnified portion of the waveform across the A sweep period to allow magnification of precisely the desired portion of waveform.
4. Apparent display jitter increases with increased magnification as is the case with delayed sweep discussed above. By cancelling the STARTS AFTER DELAY mode, B trigger LEVEL control can be used to set the trigger point.

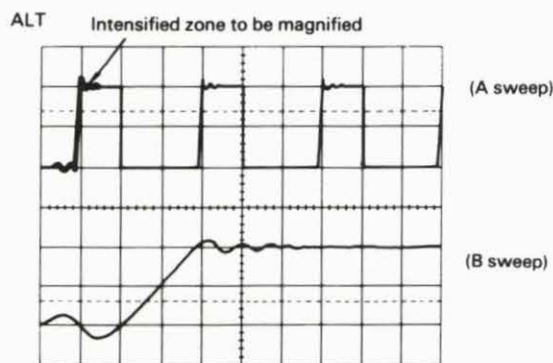

Fig. 7

## [5] X-Y OPERATION

Phase difference measurements may be made by use of the X-Y display mode.

Procedure:

Select the HORIZ DISPLAY switch to the X-Y mode. In this mode the channel 1 input becomes the Y-axis input and the channel 2 input the X-axis input for X-Y display. For X-Y operation the X and Y positions are adjusted using the channel 2  $\blacklozenge$  POSITION, X-Y  $\blacktriangleleft\blacktriangleright$  and channel 1  $\blacklozenge$  POSITION controls respectively.

X and Y sensitivities are set by using the channel 2 and channel 1 VARIABLE, VOLTS/DIV controls respectively.

By pulling out the two above mentioned VARIABLE controls, the sensitivities of both the X and Y axis are magnified by 5 times. A INTENSITY control is used to adjust the intensity of the display during X-Y operation.

## [6] SINGLE SWEEP OPERATION

This mode of display is useful for looking at non-synchronous or one time events.

Procedure:

1. Select the TRIG MODE to either AUTO or NORM. Apply a signal of approximately the same amplitude and frequency as the signal that is to be observed as the trigger signal and set the trigger LEVEL.
2. Select TRIG MODE to SINGLE and press the RESET button – observe that the red LED lights to indicate the reset condition. This LED goes out when the A sweep period is completed.
3. After the above set-up is completed the scope is ready to operate in the SINGLE sweep mode of operation after resetting the scope using the RESET button. Input of the trigger signal results in one and only one sweep.

### NOTE:

With the HORIZ DISPLAY select to ALT, the simultaneous observation of the A sweep and B sweep waveforms at SINGLE sweep mode is not possible. Also for DUAL or QUAD operation simultaneous observation is not possible using ALT mode. Set the scope to the CHOP mode in this case.

## [7] DUAL AND QUAD TRACE OPERATION

By setting the vertical MODE to DUAL or QUAD, Dual and Quad trace operations can be achieved. Additionally selecting the HORIZ DISPLAY to ALT produces up to an 8 trace.

Operation of the various controls is for this type of display mode similar to the operation described above for Alternating sweep operation.



# OPERATION

## [8] CASCADED OPERATION

This mode of operation is used when sensitivity greater than 1mV/div is required.

Procedure:

1. Connect the CH 1 OUT jack to the channel 2 input jack using a BNC cable through the 50 $\Omega$  termination.
2. For cascade operation do not pull the channel 1 and channel 2 X5 GAIN switches toward you.
3. Select vertical MODE to CH 2.
4. Set the channel 1 and channel 2 VOLTS/DIV to 5mV and input a signal for a sensitivity of 500  $\mu$ V/div on channel 1.

# APPLICATION

## PROBE COMPENSATION

If accurate measurements are to be made, the effect of the probe being used must be properly adjusted output of the measurement system using the internal calibration signal or some other squarewave source.

1. Connect the probe to the channel to be used and set the various controls for a normal A sweep display.
2. Adjust the SWEEP TIME/DIV control for display of several cycles of the signal from the calibration output, CAL, terminal.
3. Adjust the probe compensation control for a proper waveform display.
4. The other channels are compensated for in the same way.

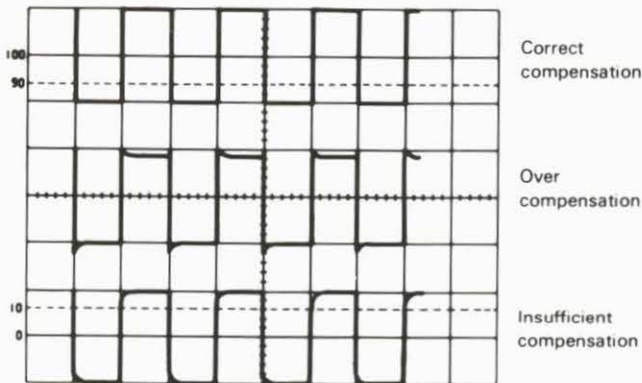

Fig. 8

## TRACE ROTATION COMPENSATION

Rotation from a horizontal trace position can be the cause of measurement errors.

Adjust the scope controls for a normal display. Set the AC-GND-DC switch to GND and TRIG MODE switch to AUTO.

Adjust the  $\blacktriangle$  POSITION control such that the trace is over the center horizontal graduation line.

If the trace appears to be rotated from horizontal, align it with the center graduation line using the TRACE ROTATION control located on the front panel.

## DC VOLTAGE MEASUREMENTS

This procedure describes the measurement procedure for dc waveforms.

Procedure:

1. Connect the signal to be measured to the vertical INPUT jack and select the vertical MODE to the channel to be used.  
Set the VOLTS/DIV and SWEEP TIME/DIV controls to obtain a normal display of the waveform to be measured. Set the VARIABLE control to the CAL.
2. Select the TRIG MODE switch to AUTO and AC-GND-DC switch to GND, which establishes a trace at the

zero volt reference. Using the  $\blacktriangle$  POSITION control, adjust the trace position to the desired reference level position, making sure not to disturb this setting once made.

3. Set the AC-GND-DC switch to the DC position to observe the waveform, including its dc component. If an appropriate reference level position was selected in step 3 or an in appropriate or VOLTS/DIV setting was made, the waveform may not be visible on the CRT at this point (deflected completely off the screen). This is especially true when the dc component is large with respect to the waveform amplitude. If so, reset VOLTS/DIV and/or the  $\blacktriangle$  POSITION control.
4. Use the  $\blacktriangleleft\blacktriangleright$  POSITION control to bring the portion of the waveform to be measured to the center vertical graduation line of the graticule scale.
5. Measure the vertical distance from the reference level to the point to be measured, (the reference level can be rechecked by momentarily returning the AC-GND-DC switch again to GND).

Multiply the distance measured above by the VOLTS/DIV setting and is the probe attenuation ratio as well. If "x 5 GAIN" has been set multiply the value by 1/5 as well.

Voltages above and below the reference level are positive and negative values respectively.

Using the formula:

Dc level = Vertical distance in divisions  $\times$  (VOLTS/DIV setting)  $\times$  (probe attenuation ratio)  $\times$  "x 5 GAIN" value (1/5)

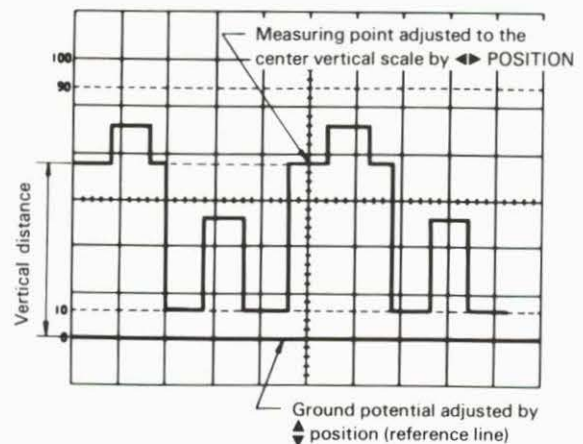

Fig. 9

### [EXAMPLE]

For the example shown in Fig. 9, the point being measured is 3.8 divisions from the reference level (ground potential).

If the VOLTS/DIV was set to 0.2V and a 10 : 1 probe was used.

Substituting the given values:

Dc level = 3.8 (div)  $\times$  0.2 (V)  $\times$  10 = 7.6V

# APPLICATION

## MEASUREMENT OF THE VOLTAGE BETWEEN TWO POINTS ON A WAVEFORM

This procedure may be used to measure peak-to-peak voltages, or for measuring the voltage difference between any two points on a waveform.

Procedure:

1. Apply the signal to be measured to the INPUT jack, select the vertical MODE to the channel to be used and set the AC-GND-DC switch to AC, adjusting VOLTS/DIV and SWEEP TIME/DIV controls for a normal display. Set the VARIABLE control to CAL.
2. Using the  $\blacktriangleleft$  POSITION control adjust the waveform position such that one of the two points falls on a major graduation line.
3. Using the  $\blacktriangleright$  POSITION control, adjust the second point to coincide with the center vertical graduation line.
4. Measure the vertical distance between the two points and multiply the number of divisions by the setting of the VOLTS/DIV control.

If a probe is used, further multiply this by the probe attenuation ratio, if any and if "x 5 GAIN" is used, multiply the value by 1/5 as well.

Using the formula:

Volts Peak-to-Peak

$$= \text{Vertical distance (div)} \times (\text{VOLTS/DIV setting}) \times (\text{probe attenuation ratio}) \times "x 5 \text{ GAIN}" \text{ value}^{-1} (1/5)$$

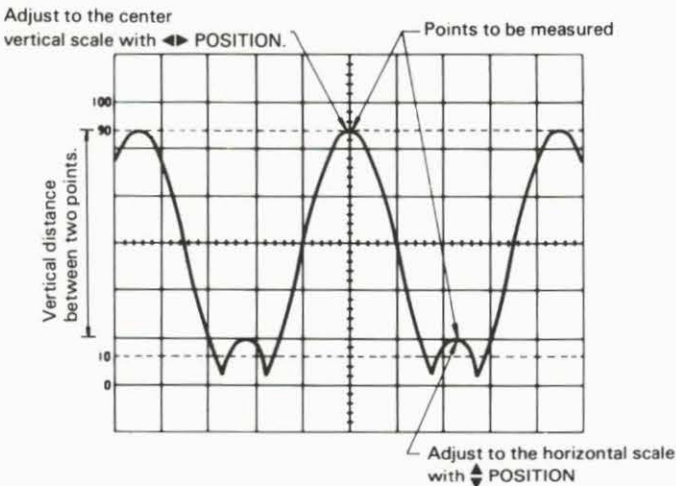

Fig. 10

### [EXAMPLE]

For the example shown in Fig 10, the two points are separated by 4.4 divisions vertically. Let the VOLTS/DIV setting be 0.2V/div and the probe attenuation be 10 : 1.

Substituting the given value:

$$\text{Voltage between two points} = 4.4 (\text{div}) \times 0.2 (\text{V}) \times 10 = 8.8\text{V}$$

## ELIMINATION OF UNDESIRE SIGNAL COMPONENTS

The ADD feature can be conveniently used to cancel out the effect of an undesired signal component which is superimposed on the signal you wish to observe.

Procedure:

1. Apply the signal containing an undesired component to the channel 1 INPUT jack and the undesired signal itself alone to the channel 2 INPUT jack.
2. Select the vertical MODE switch to DUAL (CHOP) and SOURCE switch to CH2. Verify that channel 2 represents the unwanted signal in reverse polarity. If necessary, reverse polarity by setting CH2 to INV.
3. Select the vertical MODE switch to ADD, SOURCE switch to V MODE and CH2 VOLTS/DIV and VARIABLE controls so that the undesired signal component is cancelled as much as possible. The remaining signal should be the signal you wish to observe alone and free of the unwanted signal.

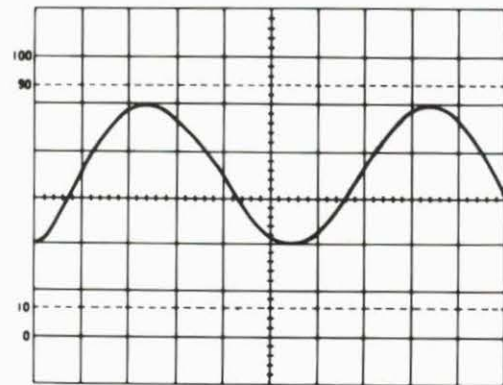
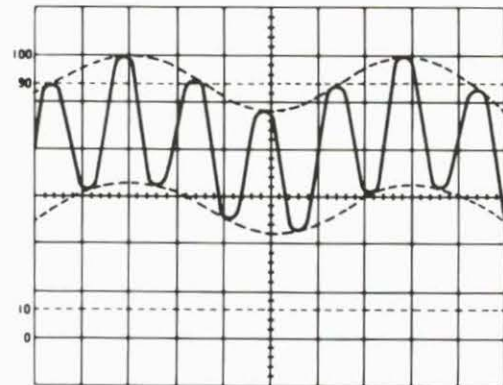

# APPLICATION

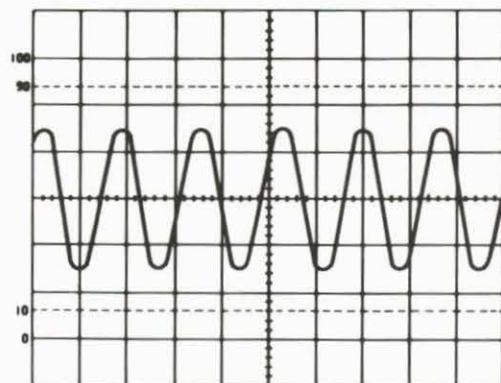

Signal without undesired component

Fig. 11

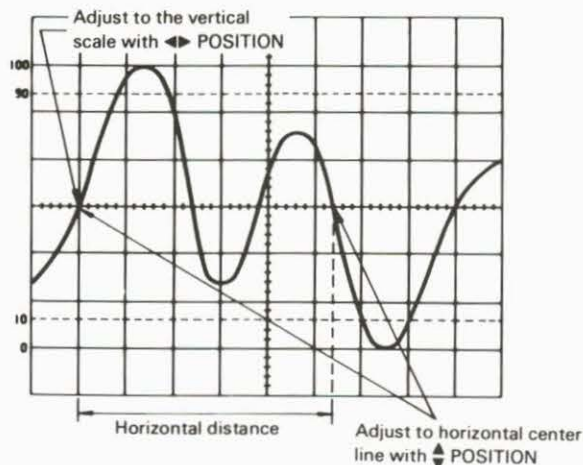

Fig. 12

## TIME MEASUREMENTS

This is the procedure for making time measurements between two points on a waveform. The combination of the SWEEP TIME/DIV and the horizontal distance in divisions between the two points is used in the calculation.

Procedure:

1. Apply the signal to be measured to the INPUT jack and select the vertical MODE switch to the channel to be used. Adjust VOLTS/DIV and SWEEP TIME/DIV controls for a normal display.

Be sure that the VARIABLE control is set to CAL.

2. Using the  $\updownarrow$  POSITION control set one of the points to be used as a reference to coincide with the horizontal centerline.

Use the  $\leftarrow\rightarrow$  POSITION control to set this point at the intersection of any vertical graduation line.

3. Measure the horizontal distance between the two points.

Multiply this by the setting of the A SWEEP TIME/DIV control to obtain the time between the two points. If horizontal "x 10 MAG" is used, multiply this further by 1/10.

Using the formula:

Time = Horizontal distance (div)  $\times$  (SWEEP TIME/DIV setting)  $\times$  "x 10 MAG" value<sup>-1</sup> (1/10)

### [EXAMPLE]

For the example shown in Fig. 12, the horizontal distance between the two points is 5.4 divisions.

If the SWEEP TIME/DIV is 0.2 ms/div we calculate.

Substituting the given value:

Time = 5.4 (div)  $\times$  0.2 (ms) = 1.08 ms

## FREQUENCY MEASUREMENTS

Frequency measurements are made by measuring the period of one cycle of waveform and taking the reciprocal of this time value as the frequency.

Procedure:

1. Set the oscilloscope up to display one cycle of waveform (one period).
2. The frequency is the reciprocal of the period measured.

Using the formula:

$$\text{Freq} = \frac{1}{\text{period}}$$

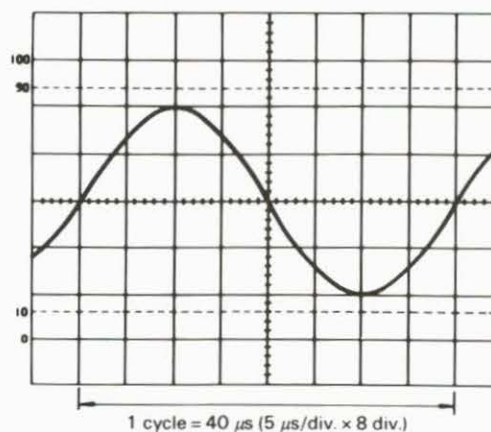

Fig. 13

### [EXAMPLE]

For the example shown in Fig. 13, a period of 40  $\mu$ s is observed and measured.

Substituting the given value:

Freq =  $1/[40 \times 10^{-6}] = 2.5 \times 10^4 = 25 \text{ kHz}$

# APPLICATION

While the above method relies on the measurement directly of the period of one cycle, the frequency may also be measured by counting the number of cycles present in a given time period.

1. Apply the signal to INPUT jack, setting the vertical MODE switch to the channel to be used and adjusting the various controls for a normal display. Set the VARIABLE control to CAL.
  2. Count the number of cycles of waveform between a chosen set of vertical graduation lines.
- Using the horizontal distance between the vertical lines used above and the SWEEP TIME/DIV, the time span may be calculated. Multiply the reciprocal of this value by the number of cycles present in the given time span. If "x 10 MAG" is used multiply this further by 10. Note that errors will occur for displays having only a few cycles.

Using the formula:

$$\text{Freq} = \frac{\# \text{ of cycles} \times \text{"x 10 MAG" value}}{\text{Horizontal distance (div)} \times \text{SWEEP TIME/DIV setting}}$$

### [EXAMPLE]

For the example shown in Fig. 14, within 7 divisions there are 10 cycles. The SWEEP TIME/DIV setting is 5  $\mu\text{s}$ .

Substituting the given value:

$$\text{Freq} = \frac{10}{7 \times 5 (\mu\text{s})} = 285.7 \text{ kHz}$$

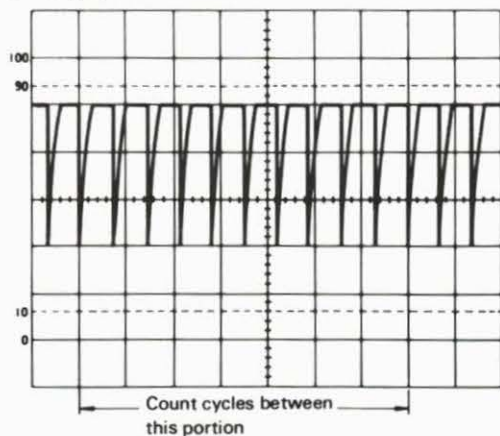

Fig. 14

## PULSE WIDTH MEASUREMENTS

Procedure:

1. Apply the pulse signal to INPUT jack and select the vertical MODE switch to the channel to be used.
2. Use VOLTS/DIV, VARIABLE and  $\blacktriangle$  POSITION controls to adjust the waveform such that the pulse is easily observed and such that the center pulse width coincides with the center horizontal line on the CRT screen.
3. Measure the distance between the intersection of the pulse waveform and the center horizontal line in divisions. Be sure that the A VARIABLE control is in the

CAL position. Multiply this distance by the A SWEEP TIME/DIV control and by 1/10 if "x 10 MAG" mode is being used.

Using the formula:

$$\text{Pulse width} = \text{Horizontal distance (div)} \times (\text{SWEEP TIME/DIV setting}) \times \text{"x 10 MAG" value}^{-1} (1/10)$$

### [EXAMPLE]

For the example shown in Fig. 15, the distance (width) at the center horizontal line is 4.6 divisions and the A SWEEP TIME/DIV setting is 0.2 ms.

Substituting the given value:

$$\text{Pulse width} = 4.6 (\text{div}) \times 0.2 \text{ ms} = 0.92 \text{ ms}$$

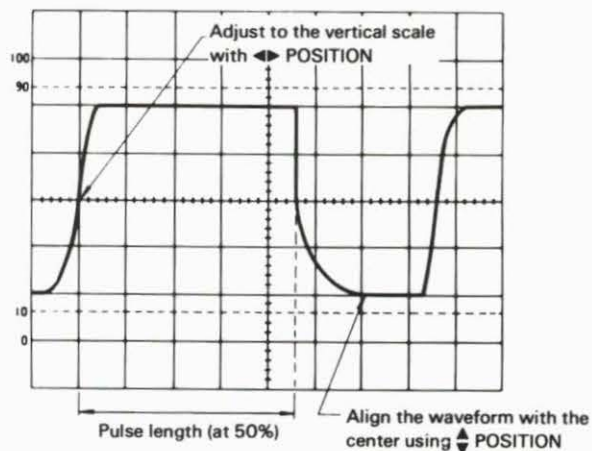

Fig. 15

## PULSE RISETIME AND FALLTIME MEASUREMENTS

For risetime and falltime measurements, the 10% and 90% amplitude points are used as starting and ending reference points.

Procedure:

1. Apply a signal to INPUT jack and select the vertical MODE switch to the channel to be used. Use the VOLTS/DIV and VARIABLE controls to adjust the waveform peak to peak height to six divisions.
2. Using the  $\blacktriangle$  POSITION control and the other controls, adjust the display such that the waveform is centered vertically in the display. Set the SWEEP TIME/DIV control to as fast a setting as possible consistent with observation of both the 10% and 90% points. Set the A VARIABLE control to CAL.
3. Use the  $\blacktriangleleft$  POSITION control to adjust the 10% point to coincide with a vertical graduation line and measure the distance in divisions between the 10% and 90% points on the waveform. Multiply this by the SWEEP TIME/DIV and also by 1/10, if "x 10 MAG" mode was used.

### NOTE:

Be sure that the correct 10% and 90% lines are used. For such measurements the 0, 10, 90 and 100% points are marked on the CRT screen.

# APPLICATION

Using the formula:

$$\text{Risetime} = \text{Horizontal distance (div)} \times (\text{SWEEP TIME/DIV setting}) \times \text{"x 10 MAG" value}^{-1} (1/10)$$

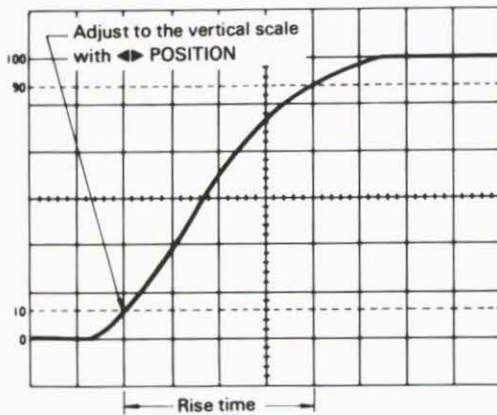

Fig. 16

[EXAMPLE]

For the example shown in Fig. 16, the horizontal distance is 4.0 divisions.

The SWEEP TIME/DIV setting is  $2 \mu\text{s}$

Substituting the given value:

$$\text{Risetime} = 4.0 (\text{div}) \times 2 (\mu\text{s}) = 8 \mu\text{s}$$

Risetime and falltime can be measured by making use of the alternate step 3 as described below as well.

- Use the  $\blacktriangleleft$  POSITION control to set the 10% point to coincide with the center vertical graduation line and measure the horizontal distance to the point of the intersection of the waveform with the center horizontal line. Let this distance be  $D_1$ . Next adjust the waveform position such that the 90% point coincides with the vertical centerline and measure the distance from that line to the intersection of the waveform with the horizontal centerline. This distance is  $D_2$  and the total horizontal distance is then  $D_1$  plus  $D_2$  for use in the above relationship in calculating the risetime or falltime.

Using the formula:

$$\text{Risetime} = (D_1 + D_2) (\text{div}) \times (\text{SWEEP TIME/DIV setting}) \times \text{"x 10 MAG" value}^{-1} (1/10)$$

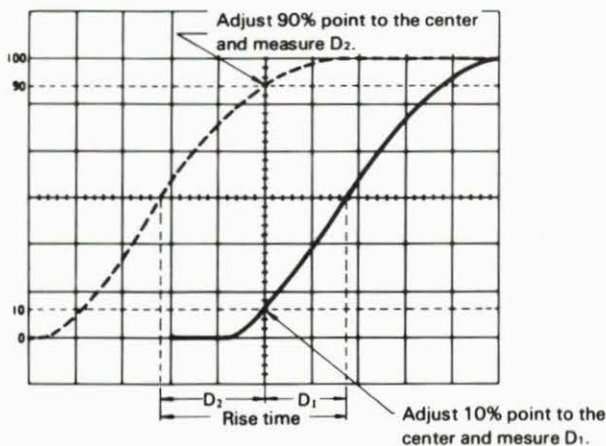

Fig. 17

[EXAMPLE]

For the example shown in Fig. 17, the measured  $D_1$  is 1.8 divisions while  $D_2$  is 2.2 divisions. If SWEEP TIME/DIV setting is  $2 \mu\text{s}$  we use the following relationship

Substituting the given value:

$$\text{Risetime} = (1.8 + 2.2) (\text{div}) \times 2 (\mu\text{s}) = 8 \mu\text{s}$$

## TIME DIFFERENCE MEASUREMENTS

This procedure is useful in measurement of time differences between two signals that are synchronized to one another but skewed in time.

Procedure:

- Apply the two signals to channel 1 and channel 2 INPUT jacks and select the vertical MODE switch to DUAL choosing either ALT or CHOP mode. Generally for low frequency signals CHOP is chosen with ALT used for high frequency signals.
- Select the faster of the two signals as the SOURCE and use the VOLTS/DIV and SWEEP TIME/DIV controls to obtain an easily observed display. Set the A VARIABLE control to CAL.
- Using the  $\blacktriangleup$  POSITION control set the waveforms to the center of the CRT display and use the  $\blacktriangleleft$  POSITION control to set the reference signal to be coincident with a vertical graduation line.
- Measure the horizontal distance between the two signals and multiply this distance in divisions by the SWEEP TIME/DIV setting. If "x 10 MAG" is being used multiply this again by 1/10.

Using the formula:

$$\text{Time} = \text{Horizontal distance (div)} \times (\text{SWEEP TIME/DIV setting}) \times \text{"x 10 MAG" value}^{-1} (1/10)$$

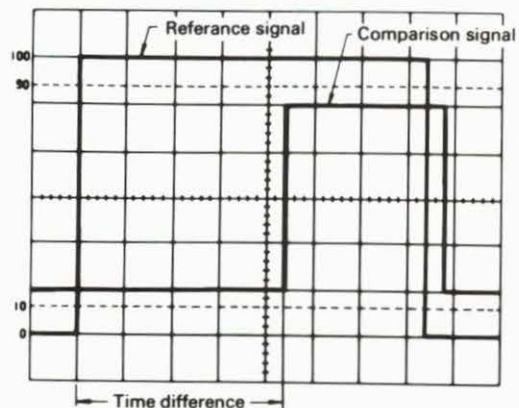

Fig. 18

[EXAMPLE]

For the example shown in Fig. 18, the horizontal distance measured is 4.4 divisions. The SWEEP TIME/DIV setting is 0.2 ms.

Substituting the given value:

$$\text{Time} = 4.4 (\text{div}) \times 0.2 (\text{ms}) = 0.88 \text{ ms}$$

# APPLICATION

## PHASE DIFFERENCE MEASUREMENTS

This procedure is useful in measuring the phase difference of signals of the same frequency.

1. Apply the two signals to channel 1 and channel 2 INPUT jacks, selecting the vertical MODE switch to DUAL and choosing either CHOP or ALT mode.
2. Set the SOURCE switch to the signal which is leading in phase and use VOLTS/DIV control to adjust the signals such that they are equal in amplitude. Adjust the other controls for a normal display.
3. Use the SWEEP TIME/DIV and A VARIABLE controls to adjust the display such that one cycle of the signals occupies 8 divisions of horizontal display. Use the  $\blacktriangledown$  POSITION control to bring the signals in the center of the screen. Having set up the display as above, one division now represents  $45^\circ$  in phase.
4. Measure the horizontal distance between corresponding points on the two waveforms.

Using the formula:

Phase difference = horizontal distance (div)  $\times 45^\circ/\text{div}$

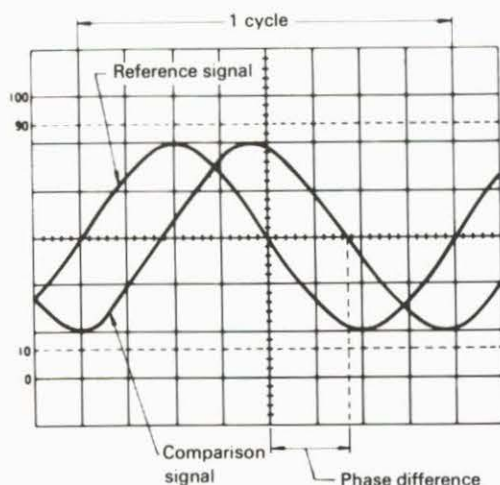

Fig. 19

### [EXAMPLE]

For the example shown in Fig. 19, the horizontal distance is 1.7 divisions.

Substituting the given value:

The phase difference =  $1.7 (\text{div}) \times 45^\circ/\text{div} = 76.5^\circ$

The above setup allows  $45^\circ$  per division but if more accuracy is required the SWEEP TIME/DIV setting may be changed and magnified without touching the A VARIABLE control and if necessary the trigger level can be readjusted.

For this type of operation, the relationship of one division to  $45^\circ$  no longer holds. Phase difference is defined by the formula as follow.

Phase difference = horizontal distance of new sweep range  
(div)  $\times 45^\circ/\text{div}$

$$\times \frac{\text{New SWEEP TIME/DIV setting}}{\text{Original SWEEP TIME/DIV setting}}$$

Another simple method of obtaining more accuracy quickly is to simply use "x 10 MAG" for a scale of  $45^\circ/\text{div}$

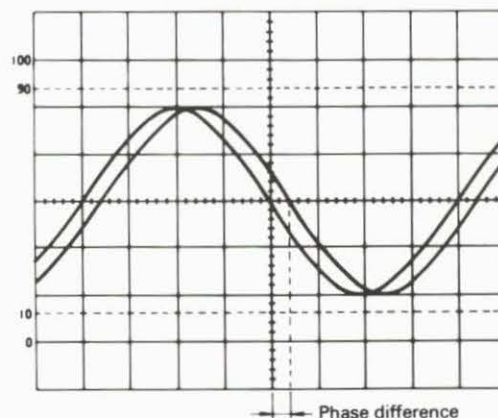

One cycle adjusted to occupy 8 div.

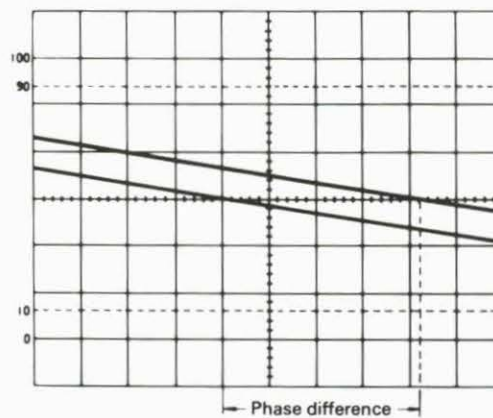

Expanded sweep waveform display.

Fig. 20

## RELATIVE MEASUREMENTS

If the frequency and amplitude of some reference signal are known, an unknown signal may be measured for level and frequency without use of the VOLTS/DIV or SWEEP TIME/DIV controls for calibration.

The measurement is made in units relative to the reference signal.

### ★ Vertical Sensitivity

Setting the relative vertical sensitivity using a reference signal.

1. Apply the reference signal to INPUT jack and adjust the display for a normal waveform display. Adjust the VOLTS/DIV and VARIABLE controls so that the signal coincides with the CRT face's graduation lines. After adjusting, be sure not to disturb the setting of the VARIABLE control.

# APPLICATION

2. The vertical calibration coefficient is now the reference signal's amplitude (in volts) divided by the product of the vertical amplitude set in step 1 and the VOLTS/DIV setting.

Using the formula:

Vertical coefficient

$$= \frac{\text{Voltage of the reference signal (V)}}{\text{Vertical amplitude (div)} \times \text{VOLTS/DIV setting}}$$

3. Remove the reference signal and apply the unknown signal to INPUT jack, using the VOLTS/DIV control to adjust the display for easy observation. Measure the amplitude of the displayed waveform and use the following relationship to calculate the actual amplitude of the unknown waveform.

Amplitude of the unknown signal (V)

$$= \text{Vertical distance (div)} \times \text{Vertical coefficient} \times \text{VOLTS/DIV setting}$$

### [EXAMPLE]

For the example shown in Fig. 21, the VOLTS/DIV setting is 1V.

The reference signal is 2 Vrms. Using the VARIABLE control, adjust so that the amplitude of the reference signal is 4 divisions.

Substituting the given value:

$$\text{Vertical coefficient} = \frac{2 \text{ Vrms}}{4 \text{ (div)} \times 1 \text{ (V)}} = 0.5$$

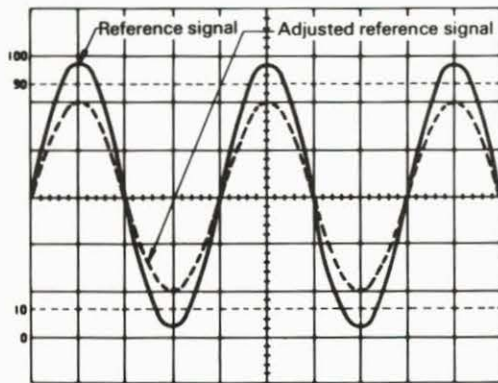

Fig. 21

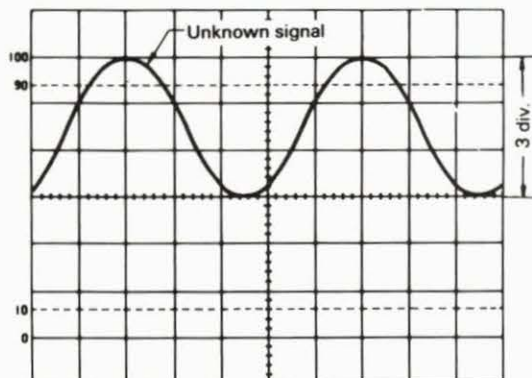

Fig. 22

Then, measure the unknown signal and VOLTS/DIV setting is 5V and vertical amplitude is 3 divisions. (Fig. 22)

Substituting the given value:

$$\begin{aligned} \text{Effective value of unknown signal} &= 3 \text{ (div)} \times 0.5 \times 5 \text{ (V)} \\ &= 7.5 \text{ V rms} \end{aligned}$$

### ★ Period

Setting the relative sweep coefficient with respect to a reference frequency signal.

1. Apply the reference signal to INPUT jack, using the VOLTS/DIV and VARIABLE controls to obtain an easily observed waveform display.

Using the SWEEP TIME/DIV and VARIABLE controls, adjust one cycle of the reference signal to occupy a fixed number of scale divisions accurately. After this is done be sure not to disturb the setting of the A VARIABLE control.

2. The sweep (horizontal) calibration coefficient is then the period of the reference signal divided by the product of the number of divisions used in step 1 for setup of the reference and the setting of the SWEEP TIME/DIV control.

Using the formula:

$$\begin{aligned} \text{Sweep coefficient} &= \frac{\text{Period of the reference signal (sec)}}{\text{Horizontal width (div)} \times \text{SWEEP TIME/DIV setting}} \end{aligned}$$

3. Remove the reference signal and input the unknown signal, adjusting the SWEEP TIME/DIV control or easy observation.

Measure the width of one cycle in divisions and use the following relationship to calculate the actual period.

Using the formula:

$$\text{Period of unknown signal} = \text{Width of 1 cycle (div)} \times \text{sweep coefficient} \times \text{SWEEP TIME/DIV setting}$$

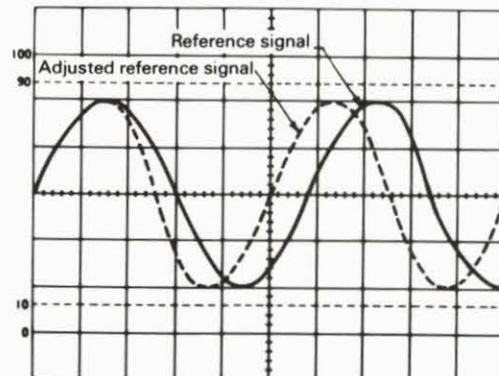

Fig. 23



## APPLICATION

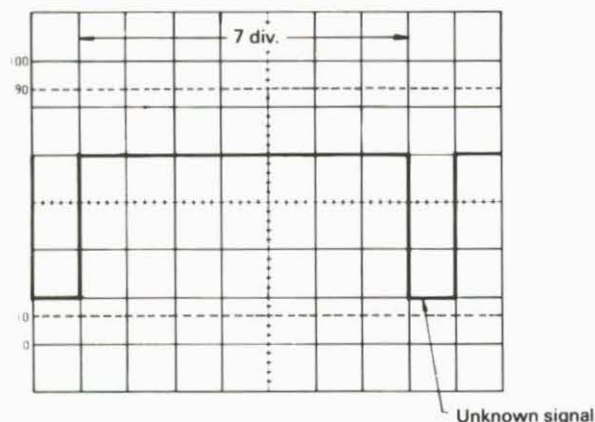

Fig. 24

### [EXAMPLE]

For the example shown in Fig. 23, A SWEEP TIME/DIV setting is 0.1 ms and apply 1.75 kHz reference signal. Adjust the A VARIABLE so that the distance of one cycle is 5 divisions.

Substituting the given value:

$$\text{Horizontal coefficient} = \frac{1.75 \text{ (kHz)}^{-1}}{5 \times 0.1 \text{ (ms)}} = 1.142$$

Then, A SWEEP TIME/DIV setting is 0.2ms and horizontal amplitude is 7 divisions. (Fig. 24)

Substituting the given value:

$$\text{Pulse width} = 7 \text{ (div)} \times 1.142 \times 0.2 \text{ (ms)} = 1.6 \text{ ms}$$

### PULSE JITTER MEASUREMENTS

1. Apply the signal to INPUT jack and set the vertical MODE switch to the channel to be used.

Use the VOLTS/DIV control to adjust for an easy to observe waveform display. Special care should be taken to adjust the Trigger group of controls for a stable display.

Set the A VARIABLE control to CAL.

2. Select the HORIZ DISPLAY switch to A-INT-B, and set the B SOURCE switch to STARTS AFTER DELAY.

Adjust the DELAY TIME MULT control for intensified display of the waveform to be measured.

3. Using the B SWEEP TIME/DIV control, adjust the display for intensification of the entire jitter area of the waveform.

4. Select the HORIZ DISPLAY switch to B DLY'D. Measure the width of the jitter area.

The jitter time is this width in divisions multiplied by the setting of the B SWEEP TIME/DIV control.

Using the formula:

$$\text{Pulse jitter} = \text{Jitter width (div)} \times \text{B SWEEP TIME/DIV setting}$$

### [EXAMPLE]

For the example shown in Fig. 25, the jitter width was measured at 1.6 divisions wide with the B SWEEP TIME/DIV setting set at 0.2  $\mu\text{s}$ .

Substituting the given value:

$$\text{Pulse jitter} = 1.6 \times 0.2 \mu\text{s} = 0.32 \mu\text{s}$$

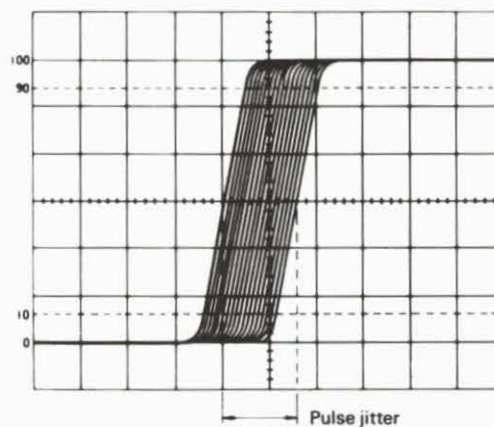

Fig. 25

### SWEEP MULTIPLICATION (MAGNIFICATION)

The apparent magnification of the delayed sweep is determined by the values set by the A and B SWEEP TIME/DIV controls

1. Apply a signal to INPUT jack and set the vertical MODE to the channel to be used, adjusting VOLTS/DIV control for an easily observed display of the waveform and the other controls if necessary.

2. Set the A SWEEP TIME/DIV control so that several cycles of the waveform are displayed. Set the B SOURCE switch to STARTS AFTER DELAY.

When the HORIZ DISPLAY switch is select to A-INT-B, the magnified portion of the waveform will appeared intensified on the CRT display.

3. Use the DELAY TIME MULT control to shift the intensified portion of waveform to correspond with the section to be magnified for observation. Use the B SWEEP TIME/DIV control to adjust intensified portion to cover the entire portion to be magnified.

4. Select the HORIZ DISPLAY switch to either ALT or B DLY'D and use the  $\blacktriangle$  POSITION and  $\blacktriangledown$  TRACE SEP controls to adjust the display for easy viewing.

5. Time measurements are performed in the same manner from the B sweep as was described above for A sweep time measurements.

The apparent magnification of the intensified waveform section is the A SWEEP TIME/DIV control divided by the B SWEEP TIME/DIV control.

Using the formula:

$$\text{The apparent magnification of the intensified waveform} = \frac{\text{A SWEEP TIME/DIV setting}}{\text{B SWEEP TIME/DIV setting}}$$

## APPLICATION

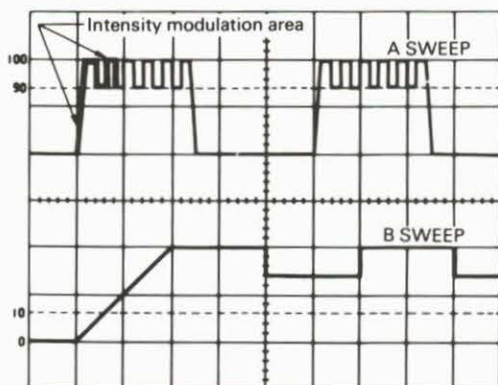

Fig. 26

### [EXAMPLE]

For the example shown in Fig. 26, the A SWEEP TIME/DIV setting is  $2 \mu\text{s}$  and the B SWEEP TIME/DIV setting is  $0.2 \mu\text{s}$ .

Substituting the given value:

$$\text{Apparent magnification ratio} = \frac{2 \times 10^{-6}}{0.2 \times 10^{-6}} = 10$$

With the above magnification, if the magnification ratio is increased, delay jitter will occur.

To achieve a stable display, cancel the STARTS AFTER DELAY mode and used the triggered mode of operation.

1. Perform the above steps 1 through 3.
2. Set the B SOURCE switch to the same signal as the A trigger source.
3. Select the HORIZ DISPLAY switch to either ALT or B DLY'D.

The apparent magnification will be the same as described above.

If a proper B trigger signal is not applied, intensification may not occur. If this happens, vary the signal level or trigger with an external signal source.

### DELAYED SWEEP TIME MEASUREMENTS

Using the B sweep high accuracy time measurements can be made.

1. Apply a signal to INPUT jack and set the vertical MODE switch to the channel to be used. Adjust the VOLTS/DIV and the other controls if necessary to obtain an easily observed waveform display. Set the A VARIABLE control to CAL.
2. Adjust the A SWEEP TIME/DIV control to display the portion of waveform to be measured. Set the B SOURCE switch to the STARTS AFTER DELAY. Select the HORIZ DISPLAY switch to A-INT-B and adjust the B SWEEP TIME/DIV control for as small as possible an intensified region.
3. Using the POSITION control adjust the waveform position so as to intersect with the center horizontal line on the CRT screen. Use the DELAY TIME MULT control so that the intensified portion of waveform touches the center horizontal line and record the setting of the DELAY TIME MULT control at this point.

4. Use the DELAY TIME MULT control to adjust intensified portion to same point of the second waveform. The waveform period is the second dial reading minus the first dial reading multiplied by the A SWEEP TIME/DIV setting.

Using the formula:

$$\text{Period} = (2\text{nd dial reading} - 1\text{st dial reading}) \times \text{Delayed sweep time (A SWEEP TIME/DIV setting)}$$

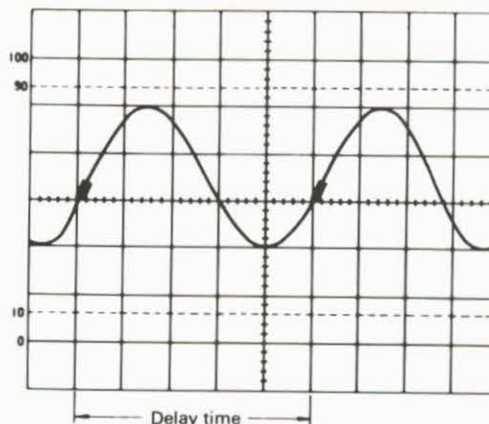

Fig. 27

### [EXAMPLE]

For the example shown in Fig. 27, the first dial setting is 1.01 and the second is 6.04. The setting of A SWEEP TIME/DIV setting is 2 ms.

Substituting the given value:

$$\text{Period} = (6.04 - 1.01) \times 2 \text{ (ms)} = 10.06\text{ms}$$

### PULSE WIDTH MEASUREMENTS USING DELAYED SWEEP

This method is similar to the time measurement method and can be used or high accuracy pluse width measurement.

1. Apply the pulse signal to INPUT jack and set the vertical MODE switch to the channel to be used.
2. Use the VOLTS/DIV, VARIABLE and POSITION controls to adjust the display such that the waveform is easily observable with the center of the pulse width coinciding with the center horizontal graduation line. Set the A VARIABLE control to CAL.
3. Set the A SWEEP TIME/DIV control to display the portion of the waveform to be measured, setting the B SOURCE switch to the STARTS AFTER DELAY. Select the HORIZ DISPLAY switch to A-INT-B, and adjust the B SWEEP TIME/DIV control for as short as possible an intensified section of waveform.
4. Using the DELAY TIME MULT control, adjust the display so that the intensified portion touches the center horizontal graduation line of the CRT screen and record the dial setting at this point.

# APPLICATION

- Using the DELAY TIME MULT control adjust the falling edge of the pulse so that it touches the center horizontal graduation line and is intensified.

The pulse width is the second dial reading minus the first dial reading multiplied by the A SWEEP TIME/DIV setting.

Using the formula:

$$\text{Pulse width} = (\text{2nd dial reading} - \text{1st dial reading}) \times \text{Delayed sweep time (A SWEEP TIME/DIV setting)}$$

### [EXAMPLE]

For the example shown in Fig. 28, the first dial reading is 0.61 and the second is 5.78 with the A SWEEP TIME/DIV setting at  $2 \mu\text{s}$ .

$$\text{Pulse width} = (5.78 - 0.61) \times 2 (\mu\text{s}) = 10.34 \mu\text{s}$$

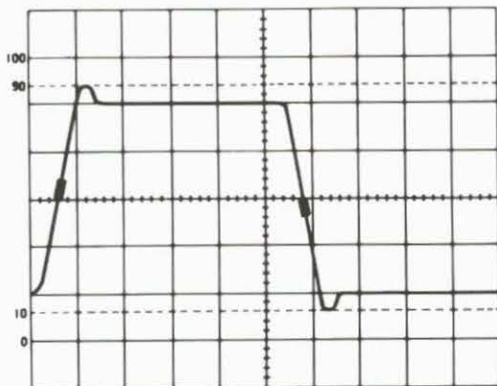

Fig. 28

## FREQUENCY MEASUREMENTS USING DELAYED SWEEP

The frequency is obtained as the reciprocal of the period of one cycle.

- Measure the period of the waveform using the procedure described above for time measurement.
- The frequency is then the reciprocal of the period measured.

Using the formula:

$$\text{Freq} = \frac{1}{\text{Period}}$$

### [EXAMPLE]

For the example shown in Fig. 29, the period measured is  $40.2 \mu\text{s}$ , making the frequency simply.

Substituting the given value:

$$\text{Freq} = 1 / (40.2 \times 10^{-6}) = 24.88 \text{ kHz}$$

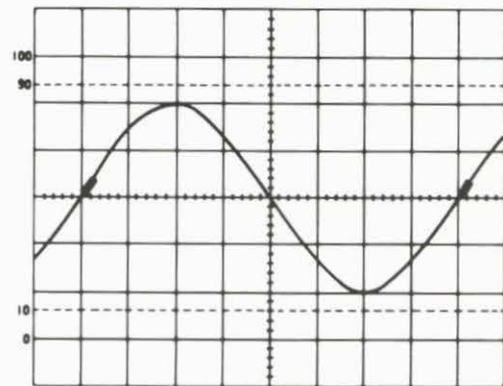

Fig. 29

## PULSE REPETITION TIME

Using the delayed sweep feature, reliable time measurements can be made.

- Apply a signal to INPUT jack and set the vertical MODE switch to the channel to be used. Adjust the VOLTS/DIV control to obtain a normal easy to view display of the waveform.
- Adjust the A SWEEP TIME/DIV control so that at least two cycles of the waveform are displayed. Select the HORIZ DISPLAY switch to A-INT-B and set the B SOURCE switch to the STARTS AFTER DELAY. Set the B SWEEP TIME/DIV control as fast a sweep speed as possible.
- Using the DELAY TIME MULT control adjust the intensified portion to coincide with the first pulse. Select the HORIZ DISPLAY switch to ALT and use the TRACE SEP control to adjust the waveforms for easy viewing.
- Using the DELAY TIME MULT control set the pulse to coincide with one of the vertical graduation lines and record the dial setting at this point.
- Again using the DELAY TIME MULT control, adjust the second pulse in the same manner to the vertical line used in step 4, recording this dial setting as well. The pulse repetition time is the second dial reading minus the first dial reading multiplied by the A SWEEP TIME/DIV control setting.

Using the formula:

$$\text{Pulse repetition time} = (\text{2nd dial reading} - \text{1st dial reading}) \times \text{Delayed sweep time (A SWEEP TIME/DIV setting)}$$

# APPLICATION

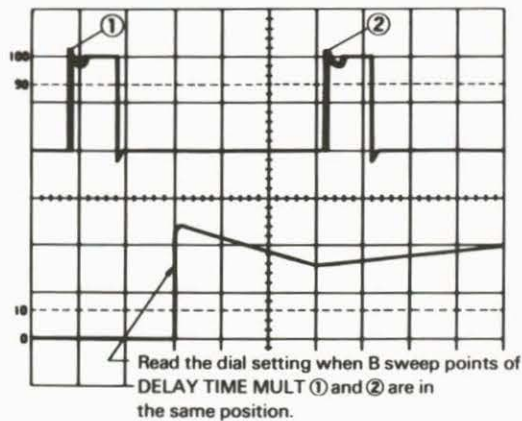

Fig. 30

## [EXAMPLE]

For the example shown in Fig. 30, the first dial reading is 0.76 and the second is 6.22 with the A SWEEP TIME/DIV set at 2  $\mu$ s.

We have, substituting the appropriate values

$$\text{Pulse repetition time} = (6.22 - 0.76) \times 2 (\mu\text{s}) = 10.92 \mu\text{s}$$

## USING DELAYED SWEEP FOR MEASUREMENT OF RISETIMES AND FALLTIMES

Risetimes and falltimes are generally measured by using the 10% and 90% amplitude points as reference starting and ending points for the rise or fall.

- Apply the signal to INPUT jack and set the vertical MODE switch to the channel to be used. Use the VOLTS/DIV and VARIABLE controls to obtain a normal 6 division high waveform display. Using the  $\blacktriangle$  POSITION control, set the waveform position in the central area of the screen vertically, that it to coincide with the 100% and 0% lines on the CRT screen. Set the SWEEP TIME/DIV to as high a speed as possible consistent with observation of both the 10% and 90% points. Set the A VARIABLE control to CAL.
- Set the B SOURCE switch to the STARTS AFTER DELAY and adjust the B SWEEP TIME/DIV control for as short as possible an intensified section of waveform.
- Using the DELAY TIME MULT control, adjust the waveform such that the 10% point is intensified and record the dial reading.
- Similarly, using the DELAY TIME MULT control adjust the 90% point so that it is intensified and record that dial reading as well. The pulse risetime (or falltime) is simply the difference between the two dial settings times the A SWEEP TIME/DIV control setting.

Using the formula:

$$\text{Risetime} = (2\text{nd dial reading} - 1\text{st dial reading}) \times \text{Delayed sweep time (A SWEEP TIME/DIV setting)}$$

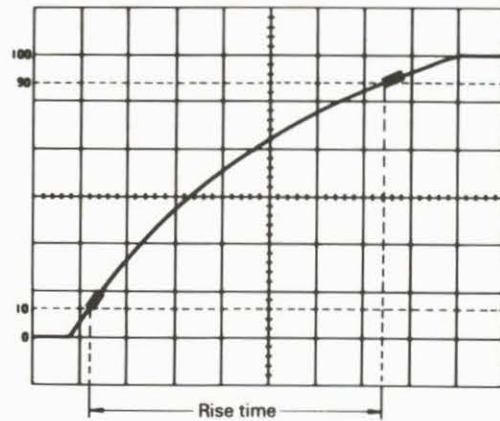

Fig. 31

## [EXAMPLE]

For the example shown in Fig. 31, the first dial reading is 1.20 (10% point) and the second is 7.38 (90% point) with the A SWEEP TIME/DIV setting set at 2  $\mu$ s.

Substituting the given value:

$$\text{Risetime} = (7.38 - 1.20) \times 2 (\mu\text{s}) = 12.36 \mu\text{s}$$

## TIME DIFFERENCE MEASUREMENTS USING DELAYED SWEEP

Synchronized waveforms which are skewed in time can be accurately measured using the delayed sweep.

- Apply the two signals to the channel 1 and channel 2 INPUT jacks, setting the vertical MODE switch to DUAL and selecting either ALT or CHOP display.
- Set the SOURCE switch to the signal that is leading in phase and adjust the VOLTS/DIV and SWEEP TIME/DIV controls for easy waveform observation. Set the A VARIABLE control to CAL.
- Set the B SOURCE switch to the STARTS AFTER DELAY. Select the HORIZ DISPLAY switch to A-INT-B and adjust the B SWEEP TIME/DIV and DELAY TIME MULT controls to make the intensified portion coincide with the rising edge or falling edge of the waveform that is to be used as the reference.
- Select the HORIZ DISPLAY switch to ALT and use the  $\blacktriangle$  TRACE SEP control to adjust the B sweep for easy observation.
- Using the DELAY TIME MULT control adjust the pulse to any convenient vertical graduation line and record the dial reading at that point.
- Using the DELAY TIME MULT control adjust the corresponding point on the second signal to the same vertical line and record the reading of the dial at this point as well. The time difference or skew of the two waveforms is then the second dial reading minus the first dial reading multiplied by the A SWEEP TIME/DIV control setting.

# APPLICATION

Using the formula:

$$\text{Time difference} = (\text{2nd dial reading} - \text{1st dial reading}) \times \text{Delayed sweep time (A SWEEP TIME/DIV setting)}$$

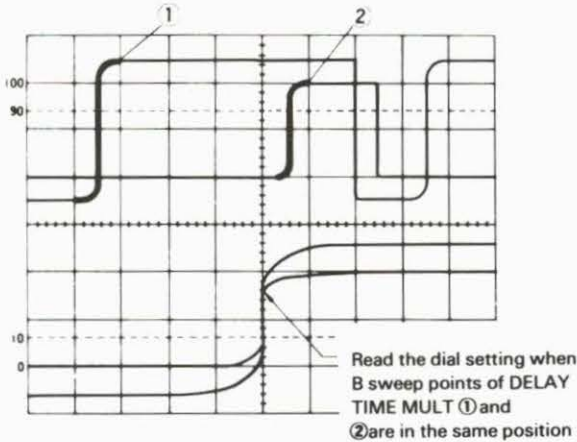

Fig. 32

## [EXAMPLE]

For the example in Fig. 32, the reference signal dial reading is 1.00 while the second dial reading is 5.34 with the A SWEEP TIME/DIV setting of 2  $\mu\text{s}$ .

Substituting the value.

$$\text{Time difference} = (5.34 - 1.00) \times 2 (\mu\text{s}) = 8.68 \mu\text{s}$$

## X-Y OPERATION

### PHASE MEASUREMENT

Phase measurements may be made with X-Y operation. Typical applications are in circuits designed to produce a specific phase shift, and measurement of phase shift distortion in audio amplifiers or other audio network. Distortion of amplitude is also displayed in the oscilloscope waveform

To make phase measurements, use the following procedure

1. Using an audio signal generator with a pure sinusoidal signal, apply a sine wave test signal at the desired test frequency to the audio network being tested.
2. Set the signal generator output for the normal operating level of the circuit being tested. If desired, the circuit's output may be observed on the oscilloscope. If the test circuit is overdriven, the sine wave display on the oscilloscope is clipped and the signal level must be reduced.

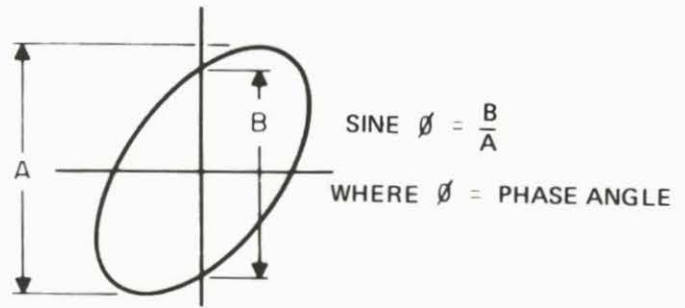

Fig. 33

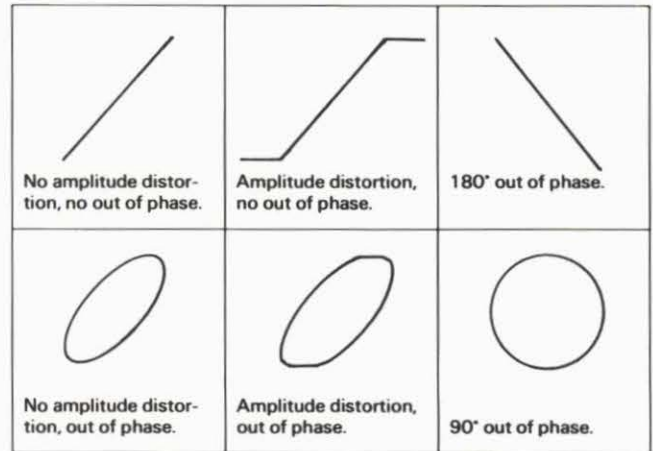

Fig. 34

3. Connect the channel 1 probe to the output of the test circuit.
4. Select the HORIZ DISPLAY switch to X-Y.
5. Connect the probe between the channel 2 INPUT jack and the input of the test circuit.
6. Adjust the channel 1 and 2 gain controls for a suitable viewing size.
7. Some typical results are shown in Fig. 34. If the two signals are in phase, the Lissajous' pattern is a straight diagonal line. If the vertical and horizontal gain are properly adjusted, this line is at a 45° angle. A 90° phase shift produces a circular Lissajous' pattern. Phase shift of less (or more) than 90° produces an elliptical Lissajous' pattern. The amount of phase shift can be calculated from the oscilloscope trace as shown in Fig. 33.

### FREQUENCY MEASUREMENT

Frequency measurement may be made with the Lissajous' pattern, as phase measurement.

Procedure:

1. Connect the sine wave of known frequency to the channel 2 INPUT jack of the oscilloscope and select the HORIZ DISPLAY switch to X-Y.
2. Connect the vertical input probe (channel 1 input) to the unknown frequency.

# APPLICATION

- Adjust the channel 1 and 2 gain controls for a convenient, easy-to-read display.
- The resulting pattern, called a Lissjous' pattern, shows the ratio between the two frequencies.

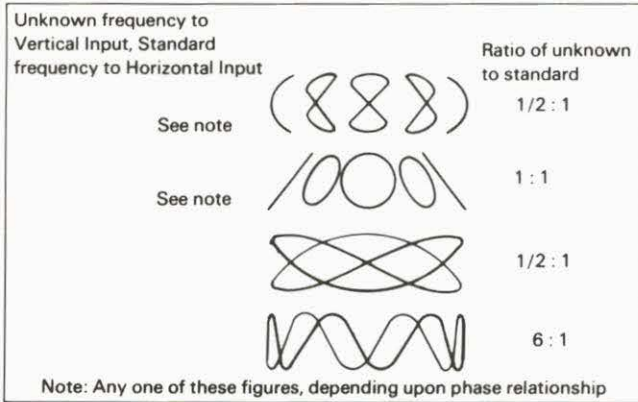

Fig. 35

## TRACE APPLICATION

sitivities of channel 1 to channel 4 are calibrated and each channel has 70 MHz band width. The trigger signals of channel 3 and channel 4 can be obtained from each preamplifiers.

This scope can be used not only for external triggering but also for checking quad-trace at a time.

### Application

- Checking logic signal timing.
  - Monitoring video signal.
  - Measuring audio signal gain and phase characteristics.
- The details of the logic signal timing checking are described below.

### Logic signal timing indication

Control setting  
 Vertical MODE: QUAD, ALT  
 HORIZ DISPLAY: A  
 A. SOURCE: CH3

To obtain stable synchronization, synchronize with the longest period channel (in this case, channel 3).

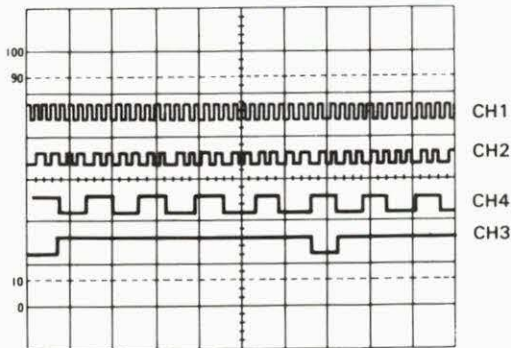

Fig 36

In the above application, when the HORIZ, DISPLAY switch is select to ALT, the main and delay sweep waveforms are displayed on the CRT at a time. The portion in which the intensity is modulated is enlarged to enable easy checking.

### Main and delay sweep waveforms (Magnified by 10 times)

Control setting  
 Vertical MODE: QUAD, ALT  
 A. SOURCE: CH3  
 HORIZ DISPLAY: ALT  
 B SOURCE: STARTS AFTER DELAY

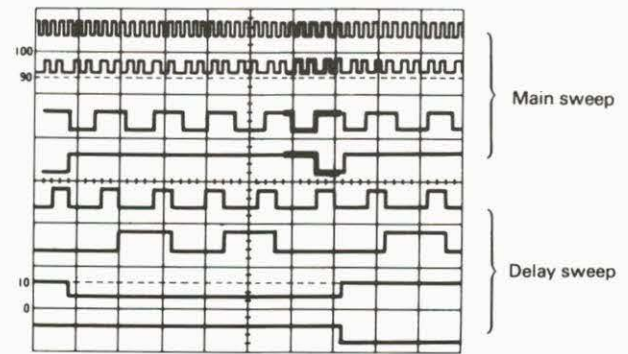

Fig. 37

# ACCESSORIES

## STANDARD ACCESSORIES INCLUDED

|                         |                              |
|-------------------------|------------------------------|
| Probe (PC-29).....      | Y87-1250-00                  |
| Attenuation.....        | 1/10                         |
| Input Impedance.....    | 10M $\Omega$ , 18 pF of less |
| Instruction Manual..... | B50-7531-00                  |
| AC Power Cord.....      | See Fig. 40                  |
| Probe Holder.....       | J21-2903-03                  |

## OPTIONAL ACCESSORIES

|                          |             |
|--------------------------|-------------|
| Probe Pouch (MC-78)..... | Y87-1600-00 |
| Service Manual.....      | B51-1036-00 |
| AC Power Cord.....       | See Fig. 40 |
| Panel Cover.....         | F07-0923-02 |

## INSTALLING PROBE HOLDER

The probe holder is attached to the handle as shown in Fig. 38. Install the probe holder as follows:

1. Rest the upper two claws of the probe holder on the top surface of the handle (see inset).
2. Push lower claws toward handle to lock probe holder in place.
3. Probe can now be inserted into holder.

### CAUTION

When disengaging the probe holder from handle, disengage lower jaw first to prevent breakage.

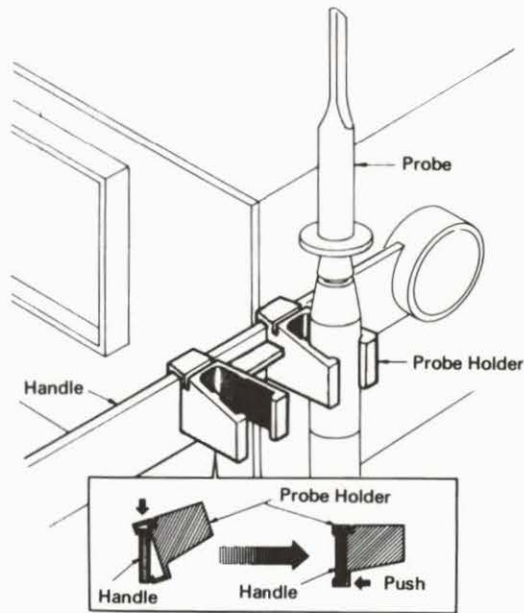

Fig. 38

# ACCESSORIES

## MOUNTING THE PROBE POUCH (MC-78)

This soft vinyl pouch attaches to the right side of the oscilloscope housing and provides storage space for two probes and the handbook. Install the probe pouch as follows:

1. Unsnap the probe pouch from the retainer plate.
2. Align the retainer plate with the 4 holes on the right side of the case, with the 4 snaps at the top.

3. Attach the four corners of the retainer plate to the oscilloscope case with the four nylon rivets supplied.
4. Attach the probe pouch to the retainer plate using the snap fastener.

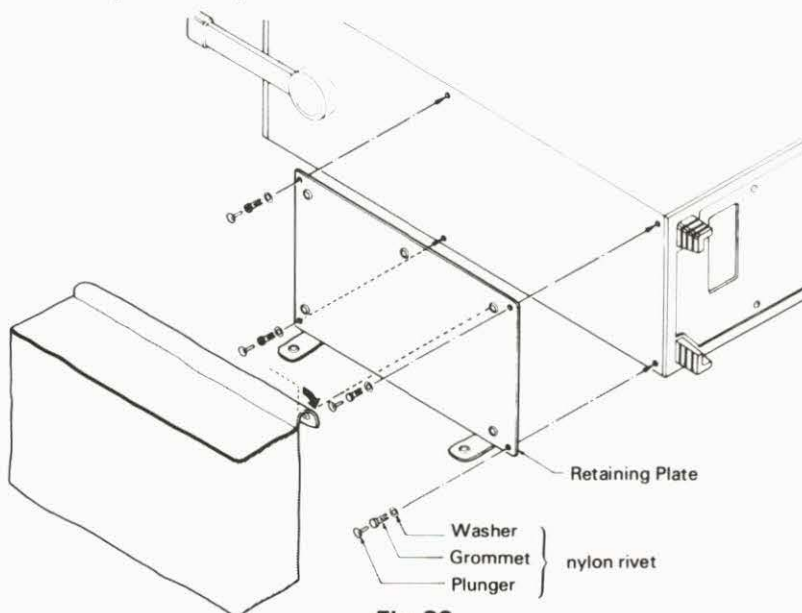

Fig. 39

| Plug configuration | Power cord and plug type  | Factory installed instrument fuse                 | Line cord plug fuse | Parts No. for power cord |
|--------------------|---|---|---------------------|--------------------------|
|                    | North American<br>120 volt/60 Hz<br>Rated 15 amp<br>(12 amp max; NEC) | 1.2 A, 250 V<br>Fast blow<br>AGC/3AG              | None                | E30-1820-05              |
|                    | Universal Europe<br>220 volt/50 Hz<br>Rated 16 amp                    | 1.2 A, 250 V<br>Fast blow<br>5 x 20 mm            | None                | E30-1819-05              |
|                    | U.K.<br>240 volt/50 Hz<br>Rated 13 amp                                | 1.2 A, 250 V<br>Fast blow<br>5 x 20 mm            | 1.2 A<br>Type C     |                          |
|                    | Australian<br>240 volt/50Hz<br>Rated 10 amp                           | 1.2 A, 250 V<br>Fast blow<br>5 x 20 mm            | None                | E30-1821-05              |
|                    | North American<br>240 volt/60 Hz<br>Rated 15 amp<br>(12 amp max; NEC) | 1.2 A, 250 V<br>Fast blow<br>AGC/3AG              | None                |                          |
|                    | Switzerland<br>240 volt/50 Hz<br>Rated 10 amp                         | 1.2 A, 250 V<br>Fast blow<br>AGC/3AG<br>5 x 20 mm | None                |                          |

Fig. 40 Power Input Voltage Configuration



MEMO

MEMO

---

A product of  
**TRIO-KENWOOD CORPORATION**  
17-5, 2-chome, Shibuya, Shibuya-ku, Tokyo 150, Japan

---